

Polyend Tracker Manual

An Official Reference for The Polyend Tracker



Contents

1	Overview	5
2	Architecture	19
3	Projects	29
4	Pattern Format	47
5	Sequencing Steps	65
6	Instruments	99
7	FX Steps	133
8	Audio	175
9	Song Mode	211
10	Master Effects	225
11	MIDI	239
12	Performance Mode	259
13	System	273
14	Index	287

Overview

The Polyend Tracker is a modern hardware implementation of a classic software music application. Trackers emerged in the late 80's as music making tools mainly on gaming machines. Later in the early 90's Trackers also became popular on personal computers. A Tracker is a utility that assembles a linear series of notes that typically triggers samples and associated parameters. Unlike standard digital audio workstations (DAW's), Trackers generally run top to bottom when playing tracks. Trackers usually had a niche community of followers and never reached the same height of popularity as other DAW's. Polyend Tracker goes a long way to reignite interest and presents the composition features of a Tracker in a modern and user friendly way. Don't be fooled by this quirky programming style of music making which may appear unusual, but does provide a very powerful and creative approach to production. Polyend Tracker presents this vintage application in a modern

and stylish box with 8 sequenced tracks and a variety of effects, MIDI and Audio In / Out and multiple workflow environments. With a small form factor and low energy usage Tracker is an ideal portable 'all in one' workstation. The feature set is wide with some interestingly creative and unexpected elements such as retro games and a radio. Tracker isn't a particularly difficult instrument to use but the unusual and less familiar core concept and workflow may mean that getting started is a little confusing and the learning curve drawn out. This may be a different twist on music production but hey, that's what makes it fun. This guide aims to help with the speed up of learning and also to get the very best from the device. As always the Synthdawg notebook style allows for your notes to be added and to make the guidebook personal for you. The Tracker journey is unusual, yet fun and at the same time a powerful music making unit giving some rewarding results. Enjoy.

1.1 How to Use This Notebook

This book combines a formal reference alongside your own notes and comments, collectively bringing together a comprehensive guide to Tracker.

Sections are laid out to cover the full workflow with walkthroughs, step by step guides and tips. Some pages carry a wide margin and some are intentionally blank enabling you to make your own notes.

Control conventions.

(Jog)

Rounded parentheses represent the large single rotary control jog wheel. Selected functions can be navigated or changed depending on the context.

[Function]

Square parentheses contain functions that are selectable by a physically dedicated button - either as a primary or secondary function. Examples are [Rec], [Play]. The arrow symbol buttons will be represented by [Left], [Right], [Up], [Down] text.

[Function] + [Option]

Functions which require multiple button selections simultaneously are shown with a + symbol between each required button. An example is the [Shift] + [Copy/Paste] command.

[PAD]

Each of the 48 pad buttons will be simply represented by [PAD]. These functions will depend on the mode and function selected.

[Dynamic Screen Key]

The 8 dynamic screen buttons located under the display will be written in this book using *italic* text. The actual function that each button serves will change depending on the current context. The function it serves will be labeled on the screen above each button on the device. Currently unavailable options will show on the tracker screen as dimmed text. An example is *Create Project*.

NOTES

Your Notes Can be written here Here

Did you know?
Music trackers emerged in the late 1980's on gaming computers?

1.2 Hardware Overview

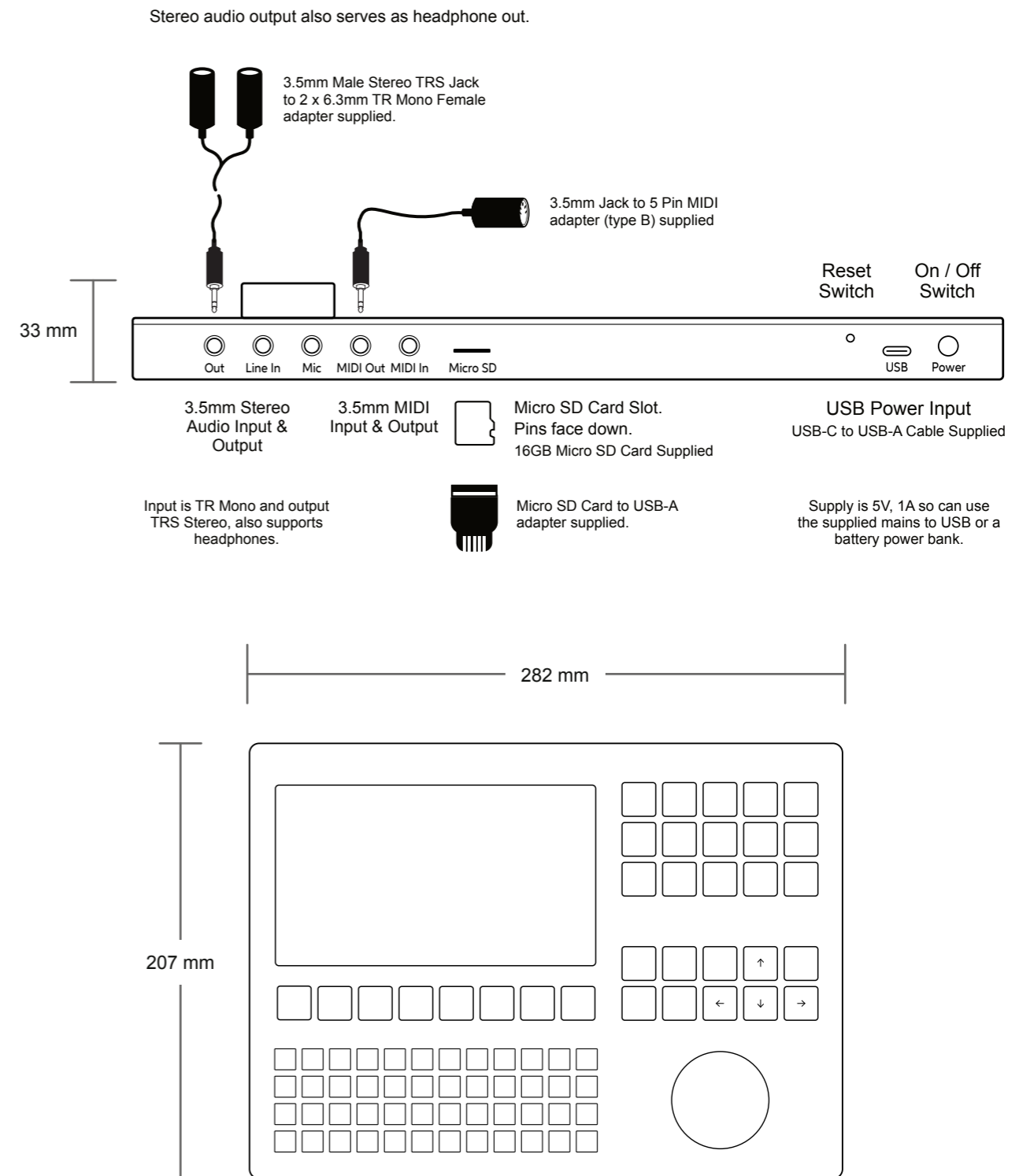

1 LCD Display
7 Inch, LCD TFT 800 x 480 Display.

3 Grid Pads
4 x 12 grid of silicon multifunctional [PADS].

5 Dedicated Note Button
Selection of the [Note] element of a step.

7 Dedicated FX1 Button
Effect selection for [FX1] of a step.

9 Dedicated Pattern Button
[Pattern] mode / page selection.

10 Sample Loader Button
[Sample Loader] opens browser for sample selection.

11 Sample Playback Button
[Sample Playback] opens playback option menu.

12 Sample Editor Button
[Sample Editor] opens editor options.

13 Sample Recorder Button
[Sample Recorder] mode / page selection.

14 Song Mode Button
[Song] mode / page selection.

15 Instrument Parameter Button
Opens the [Instrument Parameter] options.

16 Perform Mode Button
Selects the [Perform] mode / page.

18 Config Button
Opens the [Config] options.

20 Play Button
Plays when pressing [Play] the pattern or song. Pressing again stops playback. Play again restarts.

22 Insert / Home Button
Pressing [Insert/Home] will insert. Pressing [Shift] + [Insert/Home] will return 'home', to the top of the pattern.

24 Rec Button
Pressing [Rec] will toggle the record mode on or off for editing patterns and perform settings.

26 Navigation Buttons
Four navigation buttons [Up], [Down], [Left], [Right]. Used to manoeuvre through menus and options.

2 Screen Buttons
Dynamic [Screen buttons] are dependant on the function displayed above each button.

4 Jog Wheel
Rotary (Jog) wheel used for navigation and parameter adjustment.

6 Dedicated Instrument Button
Selection of the [Instrument] for a step.

8 Dedicated FX2 Button
Effect selection for [FX2] of a step.

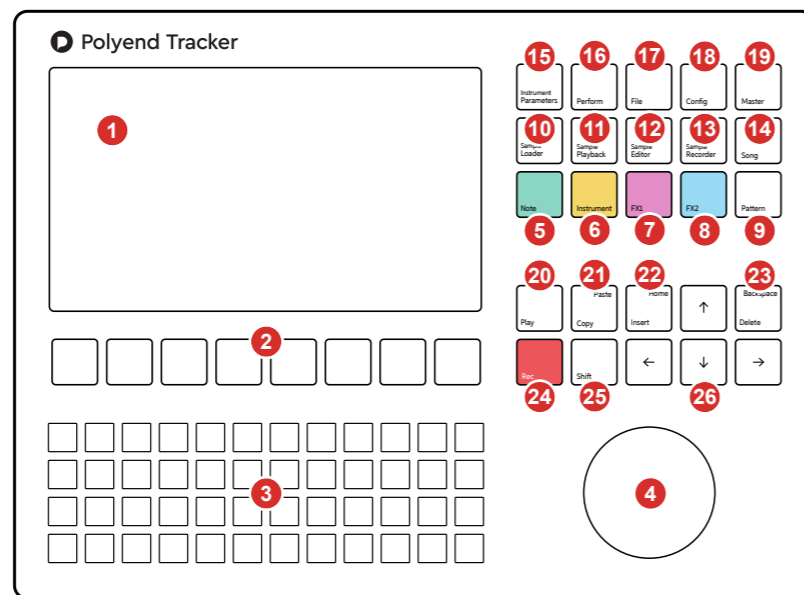

17 File Button
Selects the [File] management options.

19 Master Button
Selects the [Master] mode / page containing master effects and the mixer functions.

21 Copy / Paste Button
Pressing [Copy/Paste] will copy the selected item. [Shift] + [Copy/Paste] will paste any copied item.

23 Delete / Backspace Button
Pressing [Delete/Backspace] will reset or step back. [Shift] + [Delete/Backspace] will delete the selected item.

25 Shift Button
Pressing [Shift] + Another button will select its secondary function.

Note that while the screen brightness is adjustable, the command buttons are not backlit which may be an issue in dark environments and during live gigs and performances.

NOTES

1.3 Start Up

Tracker is a low power user and can therefore be powered from the supplied mains USB adapter or from a rechargeable battery power bank. When restarting Tracker the previously open project will be re-opened

POWERING ON / OFF TRACKER

1. Connect the supplied USB-C Mains cable between Tracker and the supplied USB plug. Also Tracker can operate with a portable USB power bank*. Tracker uses a 5V, 1A rated supply.
2. Ensure the SD Card is installed correctly for Tracker to operate.
3. Quickly press the small power button located on the rear left (looking from the top). Tracker will start up and the previous project reopened.
4. To power off, press and hold the small power button located on the rear left (looking from the top) until the timer bar ends. Tracker will power off.

Supply is 5V, 1A from the supplied mains to USB adapter.

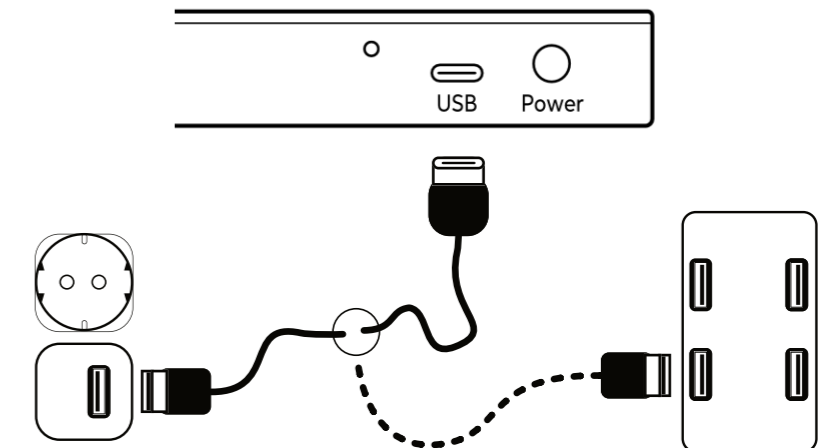

Alternatively use a battery power bank.
Start up instantaneous current is approx 1.2A with normal state around 0.5A

* It is recommended by Polyend to use a standard power bank without smart features. Intelligent / smart power banks or PC / Mac power may have features that interfere with the continuous supply required by Tracker. USC - C to USB - B cable supplied. USB - C to USB - C is usable on later Tracker models.

1.4 First Steps with Factory Projects.

At first glance, operation of Tracker appears unusual. However the workflow is quite simple once a few fundamentals are clearly understood. The quick start button commands shown here can be applied with the factory projects to get familiar with the essential processes to help speed up the learning curve. Ensure the SD Card is installed.

OPENING A PROJECT

1. When powering on the previous project will be restored. Projects can be changed or new ones created. Tracker has a maximum 100 Projects visible and accessible from the SD Card.
2. Press [File] to open the file browser.
3. Press [Open] - 2nd screen button from left. The list of available projects will be displayed on the screen.
4. Turn (Jog) or Press [Up] or [Down] to navigate the list of project options. Also press [Up] - 1st screen button or [Down] - 2nd screen button to scroll the list selection. The highlighted option will show with a bounding box.
5. With the desired project highlighted, Press [Open] - 8th / last screen button.
6. If the currently active project has been edited a prompt 'Do you want to save the changes to 'xxxx'' will be presented. Press [Save] - 8th / last screen button to save or [Don't Save] - 7th screen button from left to proceed without saving.
7. Although not essential, it is usually good practice to display the pattern page at this stage. If required, Press [Pattern] to display pattern page.

ADJUSTING THE MASTER VOLUME.

The master volume may be set loud when initially starting up. Care should be taken when playing songs and especially if listening with headphones. It is advised to firstly set the master volume lower.

1. Hold [Master] + Turn (Jog). Alternatively the [Up] and [Down] buttons can be used instead of the Jog wheel. Press [Master] + [Delete/Backspace] to incrementally increase.
2. The Volume, as displayed on the left bar, can be adjusted between -51.5dB to +12dB.

NOTES

NOTES

PLAYING A PATTERN FROM THE PATTERN OR GENERIC PAGE.

1. Ensure a project with patterns is loaded.
2. Although not essential, it is usually good practice to display the pattern page at this stage. If required, Press [Pattern] to display pattern page. Note that this will play and loop the currently selected pattern, not the entire song, unless the Song page is on display when pressing [Play].
3. Press [Play] to play the currently active pattern.
4. Press [Play] to stop playback on the current step.
 - Pressing [Play] again restarts from the pattern beginning.
 - Pressing [Shift] + [Play] will restart playback from the current paused position.
 - Press [Shift] + [Insert/Home] when play is stopped to reset the playhead to the start without commencing play.

PLAYING A SONG FROM SONG OR PERFORM PAGE.

1. Select song mode, Press [Song]. This will be applicable when a song structure has previously been created for example in factory projects.
2. Press [Play] to play the currently active song. Playback in the Song or Perform page is different to the generic pattern play from within other page views. Each row will represent a series of patterns across the 8 tracks and play rows top to bottom.
3. Press [Play] to stop playback on the current row.
 - Pressing [Play] again restarts playback starting from the beginning of the current row.
 - Pressing [Shift] + [Play] will loop playback for the current row. If playback is in a stopped state, playback will start at the beginning of the current row.
 - Press [Shift] + [Insert / Home] when play is stopped to reset the playhead to the start of the song without commencing play.

1.5 Introduction to Tracks

Tracker has 8 tracks, each of which can be configured with unique patterns made up of one or more instrument combinations. Tracks are structural elements and the track mixer is found in the master section. However some track commands are also available in the pattern pages, for example muting tracks. By default 4 tracks are displayed for patterns.

NAVIGATING TRACKS IN THE PATTERN PAGE

1. Press [Pattern] to ensure pattern page is selected. 4 Tracks are displayed by default.
2. Press [Left] or [Right] to navigate across all 8 tracks. The green or red highlighted step will anchor the navigation point.

MUTING TRACKS IN PATTERN PAGE

1. Press [Pattern] to ensure pattern page is selected. 4 Tracks are displayed by default.
2. To mute / unmute, Press [Shift] + The screen button for the respective track. All 8 tracks are presented by the screen buttons when holding the shift button. Muted tracks display in the screen keys dimmed.
3. Muting will be applied immediately the screen button is pressed. This is different in the track mixer, where muting is applied when the mute button is released.

CHANGING TRACK VIEW IN THE PATTERN PAGE

- 8 Tracks with only Note parameter: Press [Pattern] + [Note].
- 8 Tracks with Instrument parameter: Press [Pattern] + [Instrument].
- 8 Tracks with only FX1 parameter: Press [Pattern] + [FX1].
- 8 Tracks with only FX2 parameter: Press [Pattern] + [FX2].
- 8 Tracks with 2 selected parameters: Press [Pattern] + [P1] + [P2], where 'P1' and 'P2' are 2 from; [Note], [Instrument], [FX1], FX2].
- Revert to 4 track mode, Press [Pattern]

NOTES

1.6 QWERTY Keyboard.

Some pages will require text editing for naming tracks or projects etc. The same functionality applies whenever the Alpha numeric pop-up editor is used. The screen will display the QWERTY keys and the text to edit, while the 4 x 12 pad grid will act as the keyboard's keys. The screen buttons are used to enter, cancel or save.

The screen will display the keys which are represented by the grid pads. The 'f' and 'j' keys are highlighted to give a reference between the pads and the screen characters.

1	2	3	4	5	6	7	8	9	0	Backspace	
q	w	e	r	t	y	u	i	o	p	-	+
a	s	d	f	g	h	j	k	l	@	Caps Lock	
z	x	c	v	b	n	m	Space				

Enter										Cancel	Save
-------	--	--	--	--	--	--	--	--	--	--------	------

The characters and the title can be selected by using [Up], [Down], [Left] or [Right] to navigate and Press [Enter] - 1st Screen Button to select the character.

Option to [Cancel] - 7th from Left Screen Button is also possible. Save when complete using [Save] - 8th Screen Button to save the name.

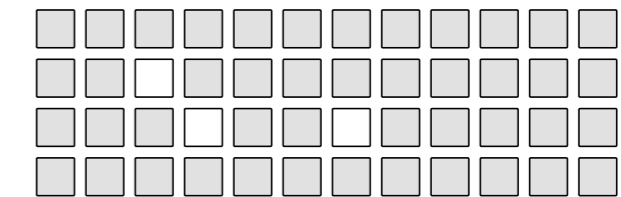

QWERTY Keyboard is represented by the 4 x 12 Grid Pads. The 'f' and 'j' keys are highlighted. The selected character using arrows will also be highlighted bright, and lit on the pads to serve as a reference. Using the pads is a simpler method in entering characters.

The following Tracker buttons operate in the naming editor when the naming screen is presented:-

- [Up], [Down], [Left], [Right] will navigate the selection across the keyboard. Will navigate left / right in the text of the name when the name is highlighted .
- [Insert/Home] will insert the currently highlighted character into the name at the cursor position.
- [Delete/Backspace] to delete characters and backspace in the name from the text cursor position.

NOTES

1.7 Page Layout.

Each page will display the information and control options for the selected function. While this may be unique to the context there are some common features and navigation principles that apply across all (or most) of the generic pages of Tracker.

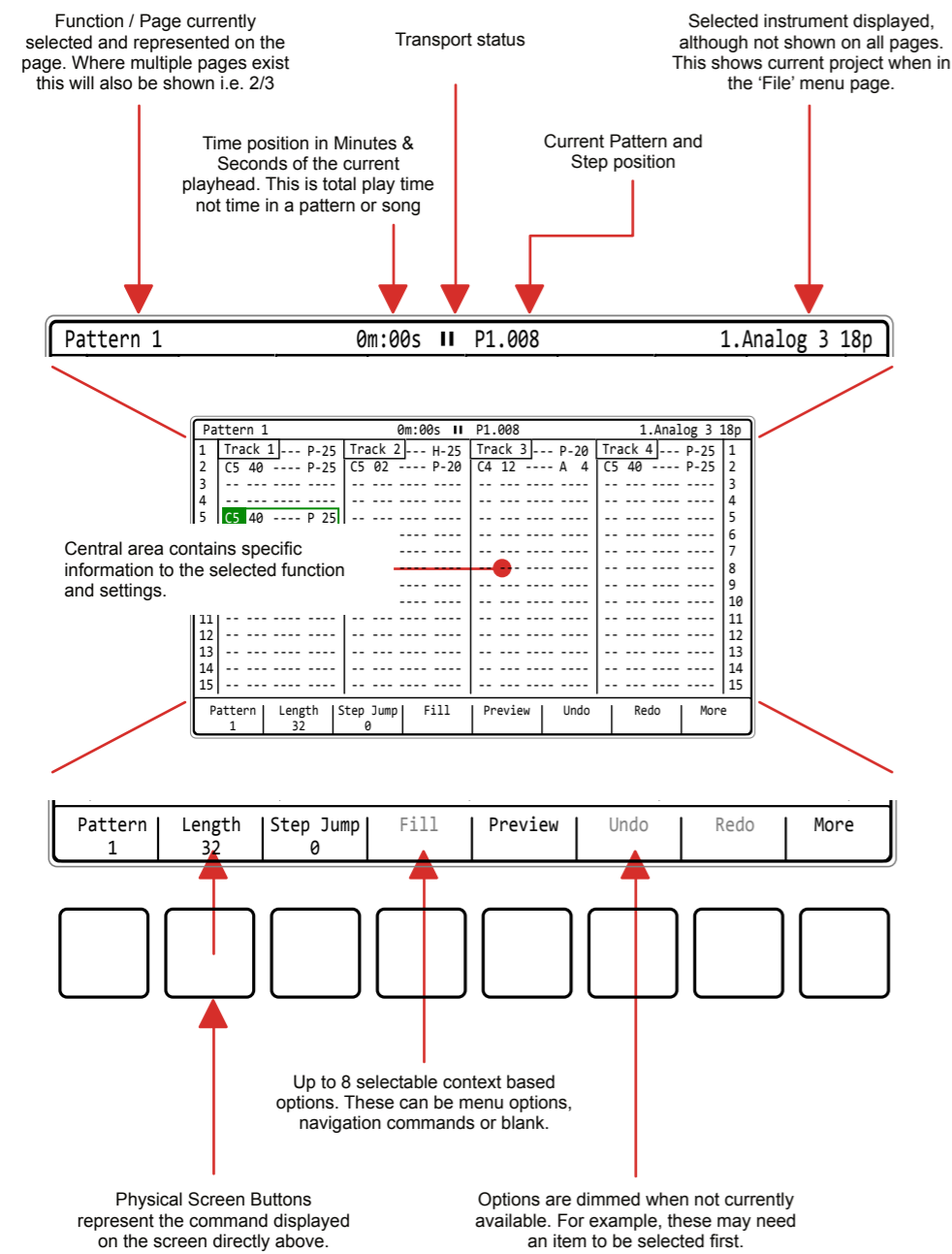

1.8 Example Workflow.

The workflow adopted with Tracker will of course develop to fit your personal approach. To get started a typical journey is described below.

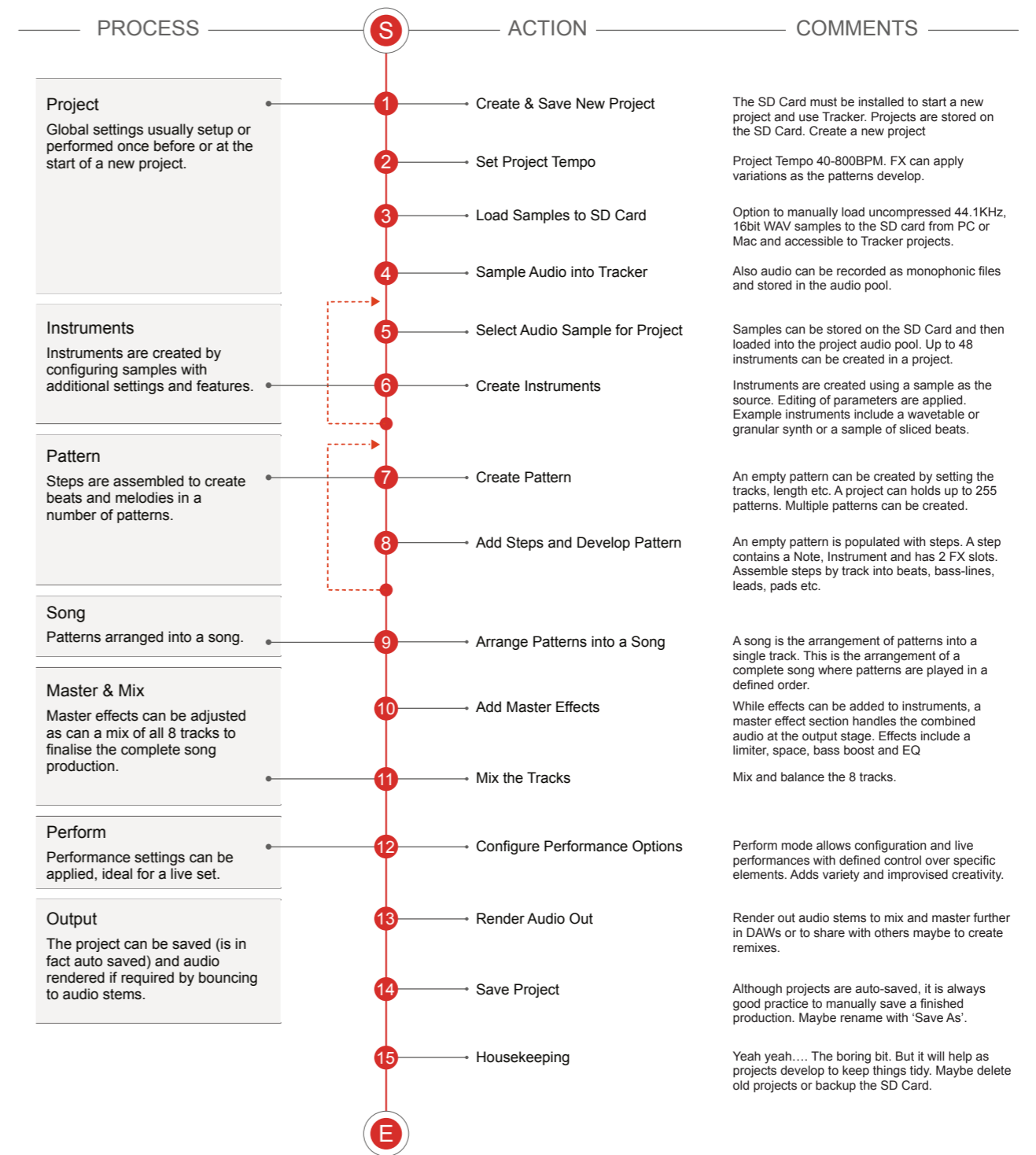

1.9 Quick Reference Commands

Function	Action	Tracker Buttons	Description
Master	Master Volume	[Master] + Turn (Jog)	Adjusts the master output
Master	Master Tempo	[Song] + Turn (Jog)	Adjusts the master tempo
Master	General Navigation	[Up], [Down], (Jog)	Generally navigate, scroll menu selections and options
Master	General Navigation	[Left], [Right]	Generally navigate, across page windows, sub menu's, functions and display columns.
Master	Copy / Paste	[Copy/Paste]	Depending on the context, will copy and paste between functions ie copy patterns.
Master	Delete / Backspace	[Delete/Backspace]	Depending on the context, will delete / backup. Will also reset any selected parameter to its default state.
Pattern	Pattern Mode Page	[Pattern]	Selects the pattern mode page.
Pattern	Play Pattern	[Play]	Plays the pattern from the start. Stops / Pauses the pattern if it is already playing
Pattern	Continue Play	[Shift] + [Play]	Restarts play of the pattern from the currently paused position
Pattern	Play Song	[Song] + [Play]	Play song from within the pattern mode page.
Pattern	8 Track Note View	[Pattern] + [Note]	Display all 8 tracks with only notes instead of default 4 tracks. 2 elements can be displayed i.e. + [FX1], [FX2], [Instrument]
Pattern	8 Track Inst View	[Pattern] + [Instrument]	Display 8 tracks with only instrument instead of 4 tracks. 2 elements can be displayed i.e. + [FX1], [FX2], [Note]
Pattern	8 Track FX View	[Pattern] + [FX1] or [FX2]	Display all 8 tracks with only FX instead of default 4 tracks. 2 elements can be displayed i.e. + [Note], [Instrument]
Pattern	4 Track View	[Pattern]	Restores default 4 tracks when viewing 8 tracks
Pattern	Check Patterns	Hold [Pattern] Screen Button	Hold pattern screen button to display the available patterns reflected by the lit pads.
Pattern	Select Pattern	[Pattern] + [Up], [Down], (Jog)	Select Pattern number
Pattern	Sequential change	[Pattern] + [Left] or [Right]	When playing, selects a new pattern to cue playback to start when the current pattern ends. Pattern blinks red.
Pattern	Sequential change	[Pattern] + [Left] or [Right]	When playing, selects a new pattern to cue playback to start when the current pattern ends. Pattern blinks red.
Pattern	Immediate change	[Pattern] + [Up] or [Down]	When playing, selects a new pattern to trigger a start immediately.
Pattern	Immediate change	[Up] or [Down] or (Jog) or [PAD]	When playing, selects a new pattern to trigger a start immediately.
Pattern	Multiple Step Select	[Shift] + [Up] [Down] [Left] [Right]	Will select groups of multiple steps for editing collectively.
Pattern	Multiple Step Select	[Shift] + [Up] On first step	Will select all steps for the current the track
Pattern	Multiple Step Select	[Shift] + [Up] + [Up] On first step	Will select all steps for all of the tracks
Pattern	Mute Tracks	[Shift] + Screen Button	Screen button 1 - 8 will toggle mute / unmute tracks 1 - 8 respectively when in pattern mode page.
Pattern	Lock Parameter Selection	Tap Dedicated Param Btn	Will lock the selection of the Note, Instrument, FX1 or FX2 parameter when editing or navigating. Also [Shift] +

1.9 Quick Reference Commands

Function	Action	Tracker Buttons	Description
Pattern	Arm / Disarm	[Shift] + [Rec] + Screen Btn	Arms or Disarms the track for recording. Disarmed tracks will not allow recording. Screen buttons represent tracks.
Pattern	Live Rec > Play	[Rec]	When live recording, pressing [Rec] will continue to play but leave recording mode.
Pattern	Live Rec Start	[Shift] + [Rec]	Start Live Recording
Pattern	Select Top Row	[Shift] + [Insert/Home]	When stopped, resets the playhead to the top row start of the song or start of the pattern.
Song Mode	Song	Press or Hold [Song]	Pressing [Song] switches to song page. Holding [Song] button will temporarily display song page from within another page.
Song Mode	Play Song	[Play]	Plays the song from the start of the current song row.
Song Mode	Stop Song	[Play]	Stops / Pauses the song playback.
Song Mode	Loop Row	[Shift] + [Play]	Loops the current song row / pattern playback
Song Mode	Select Top Row	[Shift] + [Insert/Home]	When stopped, resets the playhead to the top row start of the song or start of the pattern.
Song Mode	Tempo	[Song] + Turn (Jog)	Adjust project tempo, 40 - 800 BPM in 1 BPM increments. Also option to use [Up] or [Down] Instead of (Jog)
Song Mode	Tempo	[Shift] + [Song] + Turn (Jog)	Adjust project tempo, 40 - 800 BPM in 0.1 BPM increments. Also option to use [Up] or [Down] Instead of (Jog)
Perform	Play	[Play]	Plays pattern
Perform	Play	[Shift] + [Play]	Plays song
Perform	In Rec Mode	[Shift] + [Up], [Down] or (Jog)	Change performance effect in current slot
Perform	In Rec Mode	[Shift] + [Left] or [Right]	Swap effects between slots
Perform	In Rec Mode	[PAD] + Turn (Jog)	Edit the effect value offset for the respective pad row
Perform	Not In Rec Mode	[PAD] + Turn (Jog)	Temporary change effect value for the respective pad row
Perform	Select	[Track x]	Selects tracks to apply any triggered effect. Track labelled red.
Perform	Perform	[PAD]	Triggers the selected value for the effect for the selected track.
Perform	Remix	[Track x] + Turn (Jog)	Load a new pattern for the selected track(s) once the current pattern completes. Also use arrow keys. Live remix mode.
Perform	Remix	[Track x] + [Left] or [Right]	Load a new pattern for the selected track(s) once the current pattern completes. Also use Jog wheel. Live remix mode.
Perform	Remix	[Track x] + [Up] or [Down]	Immediately load a new pattern for the selected track(s). Live remix mode.
Perform	Mute / Unmute	[Shift] + [Track x]	Mute or unmute the selected track
Sample Loader	Navigate	Hold [Left]	In the sample loader browser hold [Left] to jump to start of the left side SD card browser.
Sample Loader	Batch Select	[Shift] + Arrows	Batch select sample in the sample loader

2

Architecture

Make no mistake, Tracker is a unique yet comprehensive device. There are so many features that are less obvious to producers more familiar with more traditional sequencers and DAW's. The overall structure of Tracker can seem at first glance, confusing. However spending a little time to understand the overall architecture and its terminology will set a good starting foundation. For this reason there are no apologies for taking time to get intimate with the architecture of the overall device and bringing this summary upfront in this guide. Getting a solid understanding and awareness of the Tracker's structure will help enormously in getting to grips later with the rest of the device. The three basic elements needed is Tracker itself (of course), a USB power source (Power-pack or mains adapter) and the correctly configured Micro SD Card which is integral to Trackers operation. While more in depth details for specific topics are covered in

the following sections of this notebook, the overall foundation and structure is laid out in this section. The hierarchical structure and organisation of data and functions such as Projects, Patterns and Steps are summarised collectively and how they work together. It is therefore worth the investment of time and focus in understanding the architectural hierarchy. Developing a fundamental workflow and efficient process will help get the most out of Trackers features.

2.1 Glossary of Terms

While you may think this should be hidden at the back of this book, understanding the terminology associated with these topics and especially the Tracker will help unlock its power and performance. It makes sense to become familiar early with the essential terms to help embed into your workflow

Beta: A term normally used for pre-release software versions used for testing purposes. Polyend often release beta versions of Tracker.

Effects: Refers to the master effects used across the overall output audio.

Envelope: An envelope is used to modulate and shape parameters and audio over time. Tracker has Envelopes which can be assigned

FX: A number of assignable effects are provided to steps in the pattern. These are not traditional style effects but more like mini-applications and automation controls.

Instrument: In Tracker, an instrument starts with a sample as its source. Various parameter configurations can be applied including wavetable or granular synth applications to operate as the sound within a step. MIDI instruments to set channel and settings also can be configured.

Instrument List: Also called an instrument pool or audio pool. This is the internal memory. Samples and instruments are loaded here to be accessed by patterns.

LFO: Low frequency oscillator which is not specifically used for sound generation but more so to modulate parameters for sound design and movement. Tracker has LFO's which can be assigned.

Looping: The process of replaying audio or a pattern continuously in a defined cycle e.g. start to end then start to end.

MIDI: MIDI stands for Musical Instrument Digital Interface and is a standard protocol used for communicating between equipment. MIDI is normally applied using 5 Pin MIDI DIN connections which in some cases (i.e. with Tracker) are interfaced via a MIDI 5 Pin to 3.5mm MIDI Dongle.

Mod File. Legacy tracker files such as .mod and .it were used in classic trackers. Not compatible with current Polyend Tracker OS versions.

Mute: Muting offers variations that can be created by silencing the play out of tracks and patterns for sound design purposes and especially when playing live sets.

Note: A musical note assigned to a samples pitch and assigned to track steps to create a melody or percussive beat.

OS: Operating System is the core software that makes Tracker work. It handles how it operates and periodic updates from Polyend bring new features into use.

Parameter: The individual value of a specific function or control element. A parameter can be adjusted to affect a sound or a functions operation.

Pattern: This is the backbone and core of a Tracker sequence and contains all steps in a sequence. Patterns control how steps are played.

Perform: A mode in Tracker that provides an environment with 12 selectable effects which can be triggered live and during improvisations.

Power Bank. A portable rechargeable battery devices used to power or recharge portable equipment.

Project: The overall structural container for patterns, samples, instruments etc. A project should always be loaded to work with Tracker.

RAM Memory: While Tracker operates with the Micro SD card, on board RAM memory is also used for instruments and samples in the project.

Render: This is like internal sampling. To internally capture patterns, tracks or songs into an exportable audio sample. Sometimes render is also called 'bounce' in the producer community.

Reset: The process of restarting Tracker by loading a random OS firmware.

Sample: The basic audio element recorded or loaded into Tracker and used to create an instrument.

Sampling: The act (and art) of recording and capturing audio to be edited and creatively assembled into a new musical composition.

SD Card: A storage device that is used in Tracker for holding data, samples, project etc. Tracker is supplied with a 16GB Micro SD Card.

Solo: The ability to select an individual track to play alone and effectively mutes other tracks.

Song: A combination of tracks and patterns combined and structured into a full arrangement.

Step: In Tracker a step is the building blocks for creating melodies and beats. Each step contains a note, instrument and 2 FX slots per track and is displayed in the track rows.

Track: Tracker contains 8 tracks each which controls a voice. Tracks are used for structuring the sequencing of steps. These can be configured with steps to play a variety of instruments and develop a complete melody and beat across the 8 tracks.

Tracker: Tracker is a digital audio workstation for music production. Trackers use a linear top to bottom sequencing environment where elements are programmed into lines of tracker code.

Update: The process of installing the newest firmware. This brings new features and fixes bugs associated with previous versions.

2.2 Tracker Audio Structure

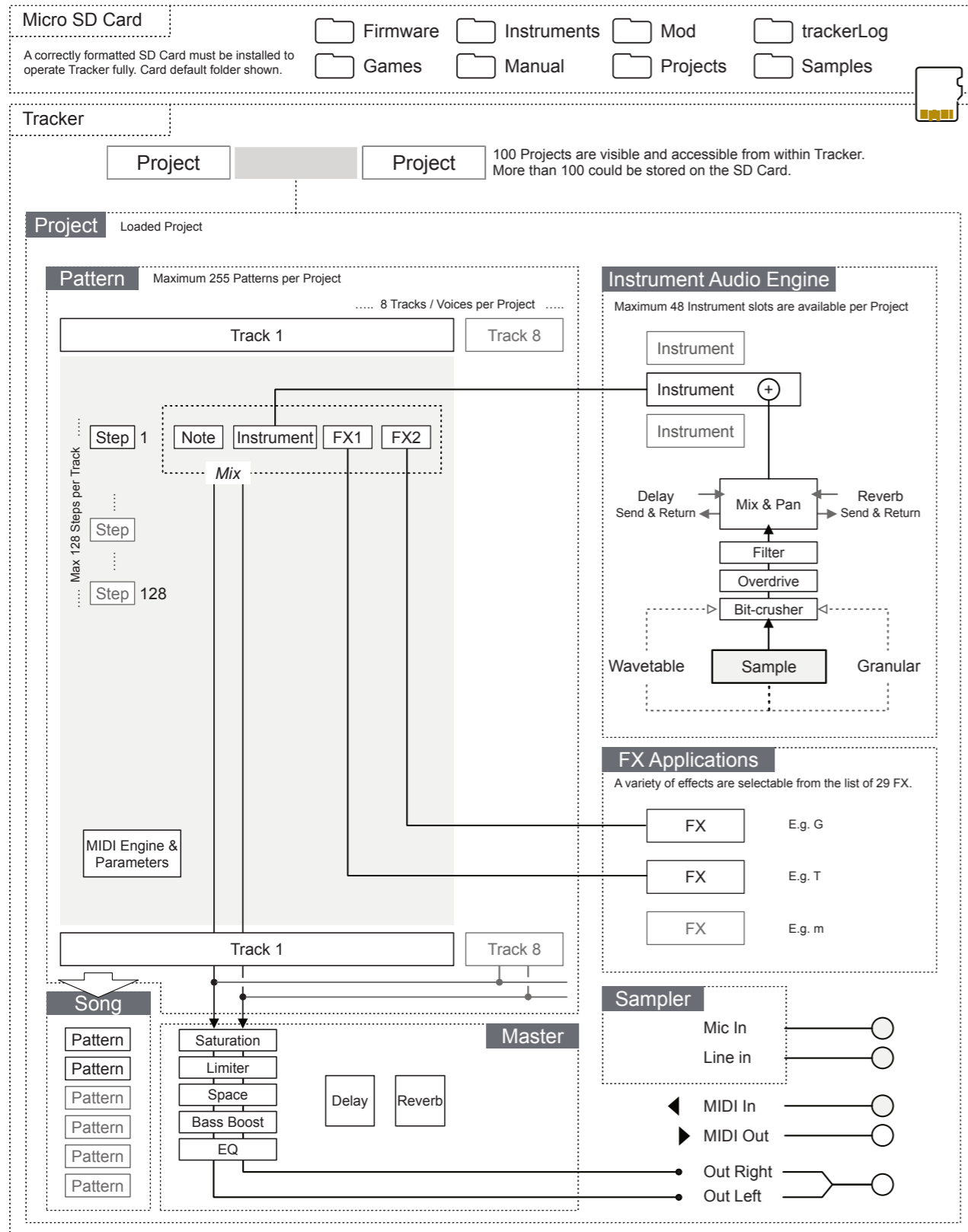

NOTES

2.3 SD Card Structure.

The Micro SD Card is an integral part of Tracker and must be inserted to operate correctly. An alert message is displayed if Tracker is powered up without an SD Card installed. It is important that the correct format is applied to the Micro SD Card. This should be FAT32 with Master Boot Record (MBR) Partitioning.

The default file structure will expand as different functions are used. For example a snapshots folder is created when capturing screen images, also export and recording folders crated once these files are firstly generated.

Files and folders can be accessed with a PC or Mac. A USB adapter is supplied with Tracker.

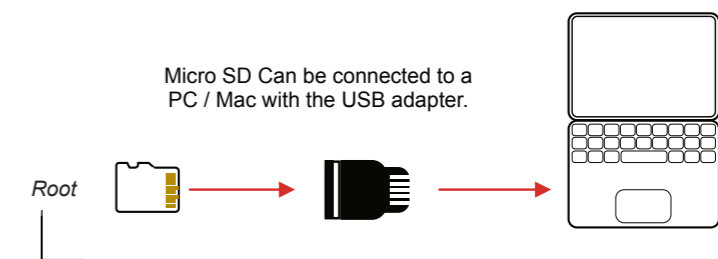

Default SD Card Structure

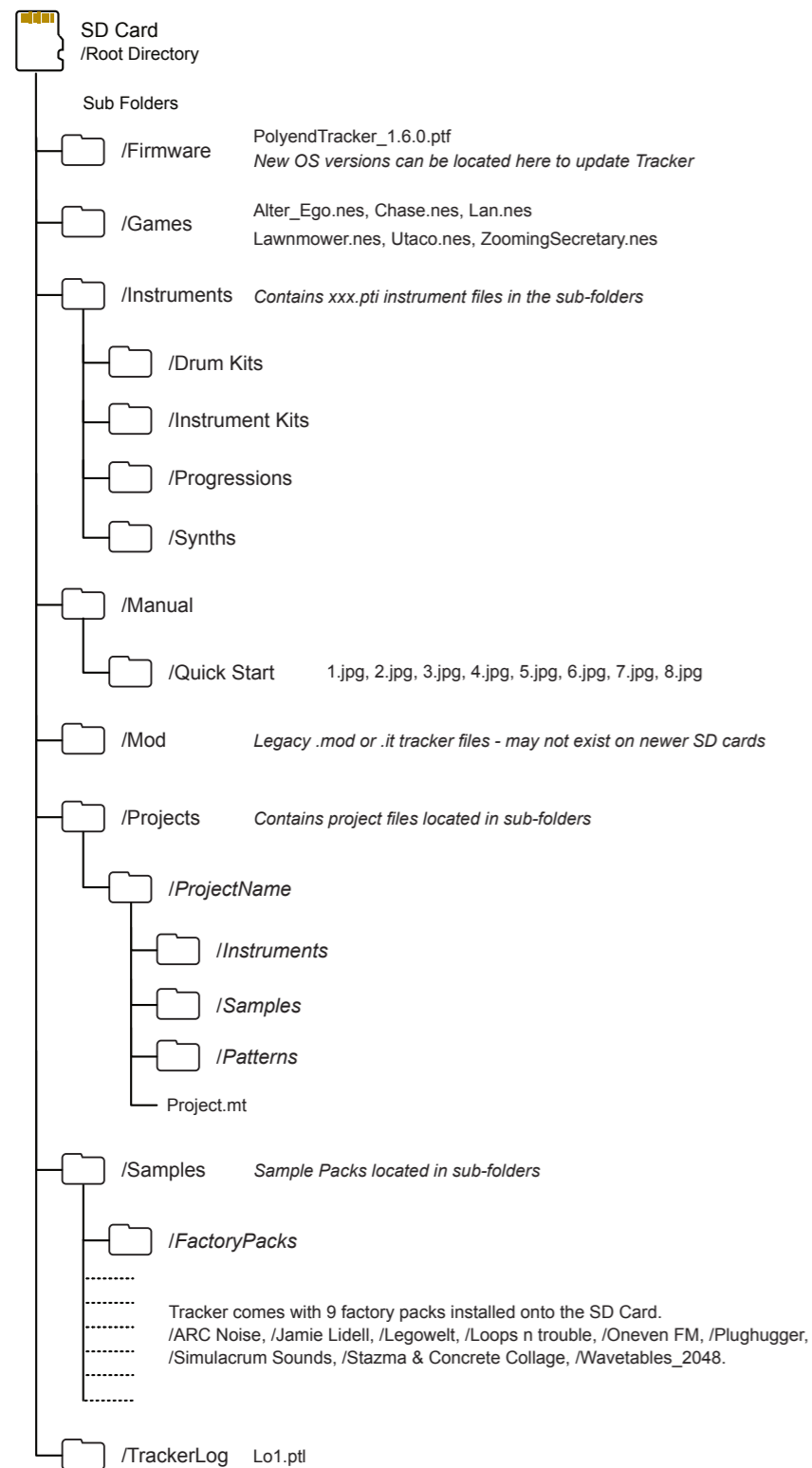

NOTES

NOTES

2.4 Internal Help & Tips.

Tracker has a series of built in tips and instructions to help get started with the functions and features. These are automatically available as text hints which appear at various stages of navigating and manoeuvring through the options and menus.

The official manual and Q&A is available on the Polyend website. A limited version of quick start is also available as the onboard manual.

VIEWING THE ONBOARD QUICK START

1. Press [Config] to open the configuration settings.
2. Navigate with the 1st and 2nd Screen Buttons to select the 'Manual'.
3. In the middle page pane, Press the 4th or 5th Screen Buttons to navigate to 'Quick Start'.
4. Press [Select], 6th Screen Button to select the options. The pop-up window will appear.
5. Navigate pages, Press [Left] or [Right].
6. Select any other function or page to exit.

2.5 Page Map

As a quick guide to the page hierarchy in Tracker the following diagram illustrates the main pages.

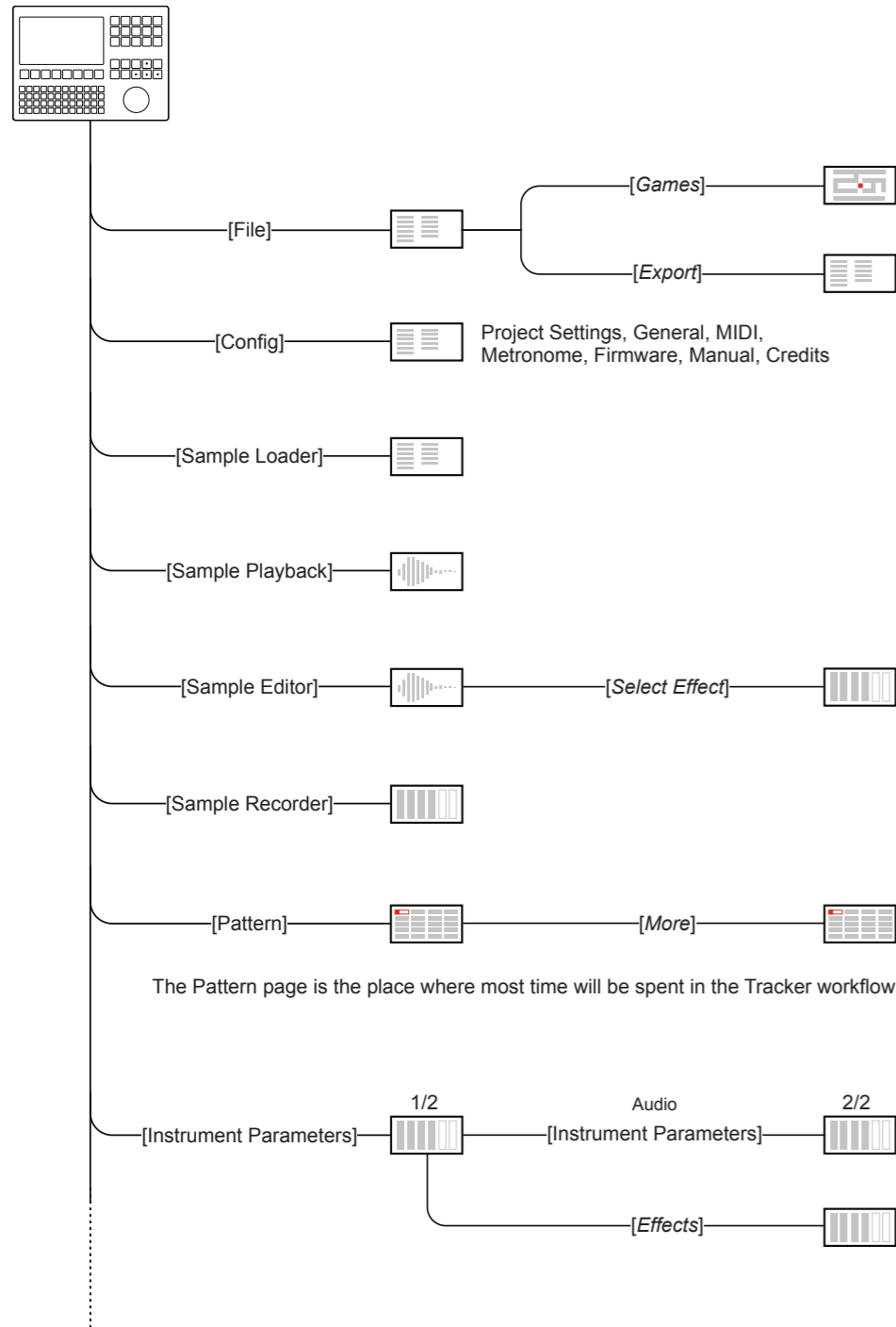

NOTES

NOTES

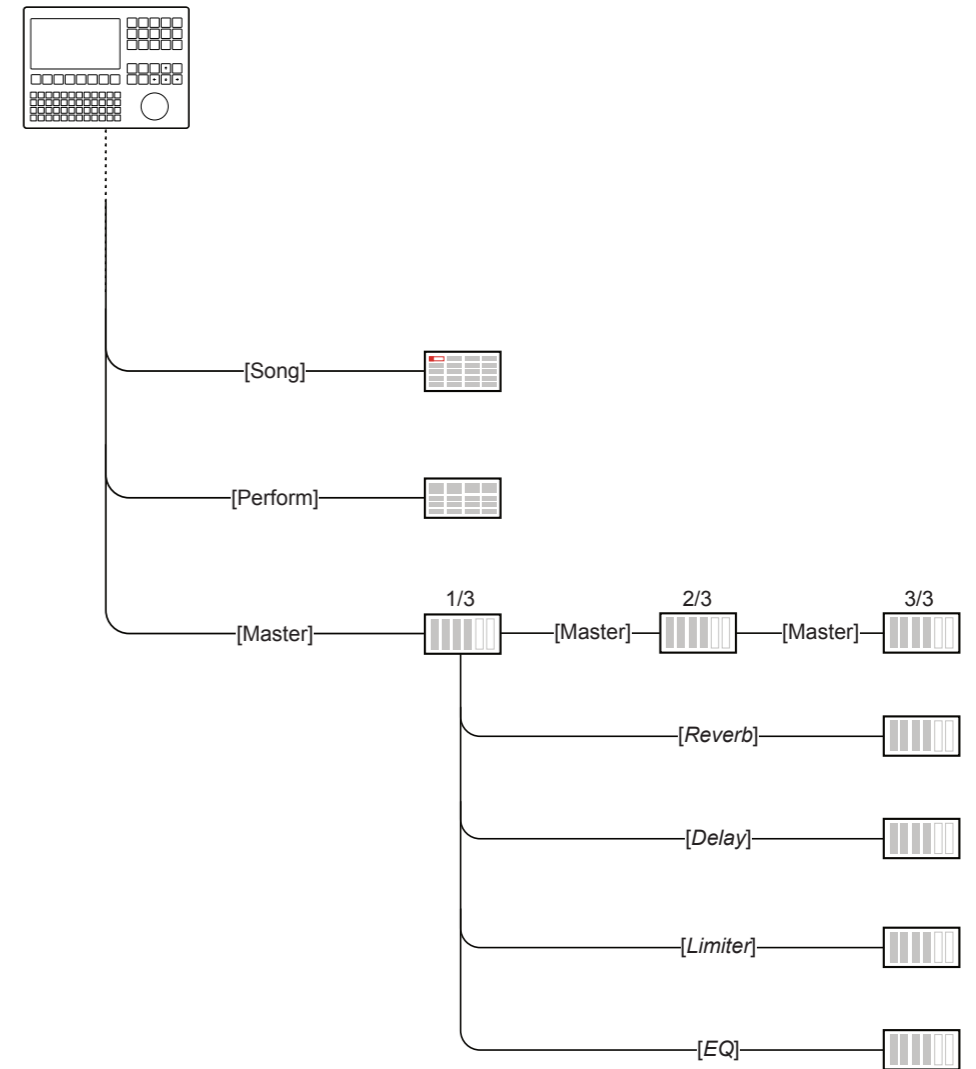

Projects

Projects are the highest order structural element in Tracker. A project contains all the elements of a full track. Think of each project as a fully arranged song for an album or a song for live set. Tracker auto saves projects, which are stored, on the installed Micro SD Card. Although the card itself can contain more, Tracker will have up to 100 projects visible and accessible. A project should be opened for playback and editing and new projects can be created from scratch. Each project contains a maximum of 255 patterns across 8 tracks. While patterns are the musical composition functions, some elements, such as the 48 available instruments are managed at project level, and hence accessible to all patterns. Projects are structural and organisational functions more so than part of the creative environment but nevertheless serve an important purpose in the Tracker workflow. Project memory for sampling is approx 133

seconds as standard although this may vary depending on the audio quality and format. Samples are stored on the Micro SD Card but can be also are held in the Tracker on board sample pool where samples effectively become instruments. Projects have an instrument pool populated with samples or instruments to be available when creating steps. This is prerequisite to creating sequences. This section covers the general project management in Tracker and it's SD card plus some key specific project level functions such as tempo.

3.1 Project Overview

A project is the highest order of Tracker's functions. It allows projects to be managed, saved and loaded and new projects to be created. Think of a project as a container for a complete song for an album or live set. Access to project level features exists in various parts of Tracker's functions and does not have a dedicated single point of access.

<p>Project - Max 100 Available in Tracker. More projects can be available on the SD Card but tracker can access 100.</p>
<p>Tracks - 8 Per Project Tracks are used to organise parts of a pattern such as bass, drums, etc</p>
<p>Patterns - 255 Patterns Per Project Patterns are sequenced into tracks to create musical elements.</p>
<p>Steps - 128 Steps per pattern These are the discrete building blocks each with a note, instrument and effects</p>
<p>Song - 255 Slots (Slots = Rows for the 8 Tracks) A song is an arrangement of patterns to create a complete production</p>

NOTES

3.2 Opening & Saving a Project - File Menu.

Projects are auto saved but can also be manually saved and renamed etc. Loading of a saved project is also possible, although on power up the previously active project will be restored. These project management functions are in the file menu. Note that projects copied to the SD card must be in the main project folder. Sub folders are not viewed directly from the 'file' menu.

CREATING A NEW PROJECT

1. Press [File] to open the file browser menu.
2. Press [*New Project*] - 1st screen button.
3. A blank project named 'NewProject' is created.

OPENING AN EXISTING PROJECT

1. Press [File] to open the file browser menu.
2. Press [*Open*] - 2nd screen button. The project list is displayed.
3. Turn (Jog) or Press [Up] or [Down] to navigate the list of projects to load. Also press [*Up*] - 1st screen button or [*Down*] - 2nd screen button to scroll the list. The highlighted option will show with a bounding box.
4. With the desired project highlighted, Press [*Open*] - 8th screen button.
5. If the currently active project has been edited a prompt 'Do you want to save the change to 'xxxx'' will be presented. Press [*Save*] - 8th / last screen button to save current project or Press [*Don't Save*] - 7th screen button from left to proceed without saving.
6. If the current pattern is new, a 'Save As' command is activated.
7. If required, Press [*Pattern*] to display pattern page.

MANUALLY SAVING THE CURRENT / EXISTING PROJECT

1. Press [File] to open the file browser menu.
2. Press [*Save*] - 5th screen button from left.
3. The project will be saved and overwrite the previous version.

NOTES

NOTES

SAVING THE CURRENT PROJECT - FIRST TIME

1. Press [File] to open the file browser menu.
2. Press [Save] - 5th screen button from left or Press [Save As] - 6th screen button from left. If using 'Save' for the first time the 'Save As' function is triggered to request a name.
3. The naming function will appear to allow a new name to be created. The [PAD] buttons will represent the alpha-numeric keyboard. Type in the name required using the [PAD] buttons.
4. Alternatively, press [Auto Name] - 6th screen button from left. This will generate a random name for the project and present it in the editor.
5. With the desired name created, Press [Save] - 8th / last screen button.
6. The project is saved and the keyboard editor function is closed.

1	2	3	4	5	6	7	8	9	0	Backspace	
q	w	e	r	t	y	u	i	o	p	-	+
a	s	d	f	g	h	j	k	l	@	Caps Lock	
z	x	c	v	b	n	m	Space				

Enter					Auto Name	Cancel	Save
-------	--	--	--	--	-----------	--------	------

QWERTY Keyboard is represented by the 4 x 12 Grid Pads. The 'f' and 'j' keys are highlighted and lit on the pads to serve as a reference. The Screen buttons offer the main commands in the context of the editor.

The following Tracker buttons also operate in the naming editor when the naming screen is presented:-

- [Up], [Down], [Left], [Right] will navigate the selection across the keyboard. Will navigate left / right in the text of the name when the name is highlighted .
- [Insert / Home] will insert the currently highlighted character into the name at the cursor position.
- [Backspace] to delete characters and backspace in the name from the text cursor position.

NOTES

3.3 Deleting a Project - File Menu.

The option to delete a project can be performed in the project browser. The currently active project cannot be deleted. Change to another project to delete. Note that deleting a project will also remove it from the SD Card.

DELETING A PROJECT

1. Press [File] to open the file browser menu.
2. Press [Open] - 2nd screen button from left. The list of available (max 100) projects will be displayed on the left of the screen.
3. Turn (Jog) or Press [Up] or [Down] to navigate the list of projects. Also press [Up] - 1st screen button or [Down] - 2nd screen button to scroll the list selection. The highlighted option will show with a bounding box.
4. With the desired project highlighted, Press [Delete] - 3rd screen button from the left.
5. A prompt 'Do you want to delete project 'xxxx' ?' will be presented.
6. To confirm, Press [Delete] - 8th / last screen button to confirm deletion. Alternatively, Press [Cancel] - 7th screen button from left to exit without deleting the project.
7. Project will be deleted from the SD Card and no longer visible in the project list on Tracker *.

** Projects also manually deleted externally from the SD Card using a PC or Mac will no longer be visible in Tracker.*

3.4 Project Tempo

The overall tempo of the project is set in the 'Song' section of Tracker and has a defined range of 40 - 800 BPM. Tempo can also be modulated by using the FX slots in a step with the 'T' Tempo effect. Note that the MIDI clock output is based on the project tempo.

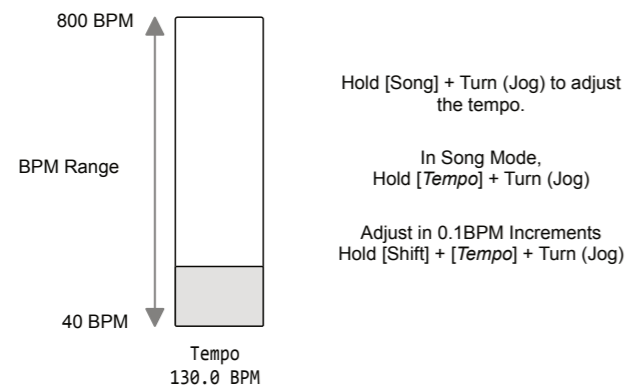
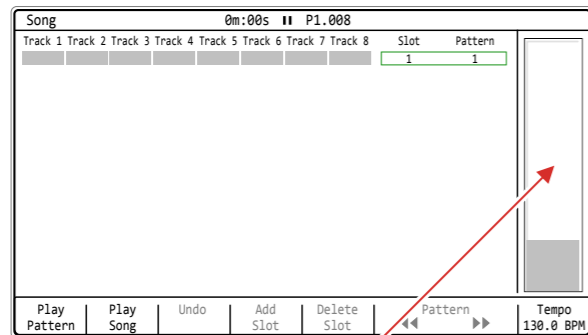

Tap tempo can be applied in Song Mode by tapping the Tempo Screen key a minimum of 4 times at the BPM desired. Count will be displayed when tapping.

Note: Pressing [Delete/Backspace] when tempo is selected will reset to the default 130 BPM. This is generic behaviour, where the [Delete/Backspace] button will reset any selected parameter to its default value.

NOTES

NOTES

QUICK ADJUSTMENT OF THE PROJECT TEMPO

1. Press [Song] + Turn (Jog) or Press [Up] or [Down] to change the tempo in 1 BPM steps. Range is 40 - 800 BPM.
2. Press [Shift] + Press [Song] + Turn (Jog) or Press [Up] or [Down] to change the tempo in 0.1 BPM steps.

GENERAL ADJUSTMENT OF THE PROJECT TEMPO

1. Press [Song] to select the Song Mode page.
2. Hold [Tempo] - Last screen button + Turn (Jog) or Press [Up] or [Down] to change the tempo in 1 BPM steps. Range is 40 - 800 BPM.
3. Hold [Shift] + [Tempo] - Last screen button + Turn (Jog) or Press [Up] or [Down] to change the tempo in 0.1 BPM steps.

TAP TEMPO ADJUSTMENT

1. Press [Song] to select the Song Mode page.
2. Tap [Tempo] - Last screen button, a minimum of four taps. The tap count will be displayed during tapping.
3. The tempo recorded is based on the speed of the taps recorded.

Note that the FX option 'T' Tempo triggers a tempo change between 10% - 400% which can therefore extend the project base tempo range.

3.5 Metronome

Tracker has a metronome which operates when live recording (not normal playback). This is configurable and selectable on/off within the 'Config' menu under the 'Metronome' options.

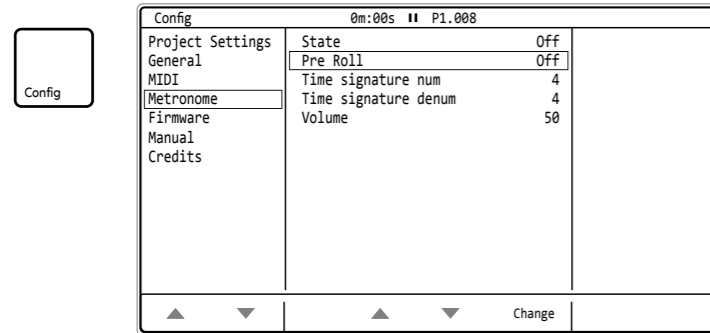

Press [Left] or [Right] to navigate between the option windows and use [Up] or [Down] to navigate to the desired option.

NOTES

NOTES

SETTING THE METRONOME

1. Press [Config] to open the project configuration menu.
2. Ensure the left window is highlighted red i.e. in focus. Navigate windows by pressing [Left] or [Right]. Menu windows will automatically be selected when pressing the relevant screen keys below the window to navigate [Up] or [Down].
3. Press [Up] [Down] or Turn (Jog) to highlight with the bounding box over the 'Metronome' option. Alternatively press the relevant screen keys below the window to navigate [Up] or [Down].
4. Press the relevant screen keys below the window to navigate [Up] or [Down] under the central options to highlight with the bounding box over the required Metronome option.
5. To change the selected parameter / setting, Press [Change], 6th Screen button. The parameter pop-up window listing the available options will appear.
6. Turn (Jog) or Press [Up] / [Down] or [Up] / [Down] Screen Buttons to highlight the desired option.
7. Press [Apply], 6th Screen button to confirm selection or [Cancel], 3rd Screen button to exit without changing.
8. The metronome will operate at the chosen time signature and volume when live recording is activated using [Rec] + [Play]. The Pre roll will provide a count in of 4 and show the 'Recording in 4. 3. 2. 1.' message before starting to record.

Metronome Settings.

Option	Parameters	Description
State	On, Off Default Off	Toggles the metronome on or off.
Pre Roll	On, Off Default Off	Sets a count in before the sequencer starts to help timing of punch in recording. Ideal for live recording.
Time signature num	1 - 12 Default 4	Number of beats in a measure / bar. Upper number in the normal time signature value. Example 4/4 set to 4 beats per measure.
Time signature denum	1 - 12 Default 4	Beat value, division of note. Lower number in the normal time signature value. Example 4/4 has a quarter note per beat.
Volume	1 - 100 Default 50	Volume of the metronome's 'tick' sound

3.6 Project Pool & Instrument List

A pre-requisite for creating patterns is to have a series of instruments available to record or program into steps. Instruments are based on the samples loaded into the project pool and parameters applied to create instruments. Instruments can also be loaded from other projects but must exist in the current project instrument list to be accessible to the pattern steps. A maximum of 48 instruments are available per project depending on the sample size and hence memory usage.

An instrument or sample from the SD Card libraries can be added into the active project instrument list. The instrument list is used to configure steps.

Basics of setting up a project instrument list using the [Sample Loader] function is shown here and further details on the sample management is detailed later.

Press [Left] or [Right] to navigate between the option windows a red bounding box will indicate the selected window. Press [Up] or [Down] or Turn (Jog) to navigate to the desired listed option.

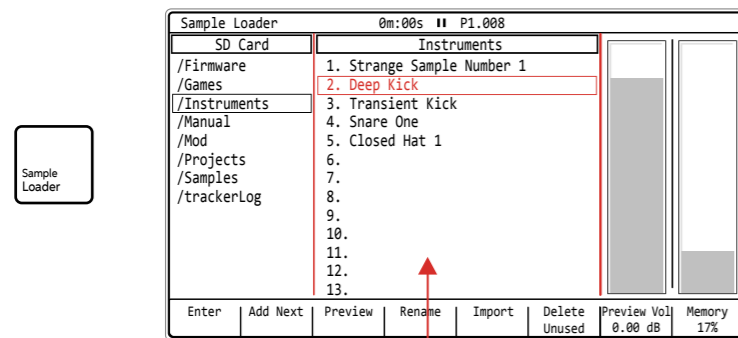

Window display pans between SD Card and Instrument List. Max 48 instruments can be stored in a Tracker project.

Project memory available based on the selected samples / instruments in the instrument list.

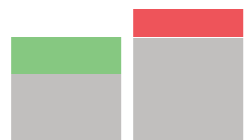

The bar will show an additional red element - if memory will increase and green bar - if memory will decrease when browsing a sample / instrument indicating potential memory impact if sample / instrument is added.

NOTES

NOTES

CREATING A PROJECT INSTRUMENT LIST

1. Press [Sample Loader] to open the sample browser and instrument list utility page.
2. Navigate to the central 'Instruments' window and highlight either an empty slot or an existing instrument. If an existing instrument is highlighted it will be replaced by the newly selected choice.
3. Navigate to the left 'SD Card' window and highlight either instruments or samples. Use the [Up] or [Down] or Turn (Jog) to navigate and Press [Enter] screen button to select folder. Use [Shift] + Arrows to batch select multiple samples / instruments.
4. With a sample or instrument highlighted in the left window, press the [Add], 1st Screen button. This will add or replace in the selected instrument slot. Using [Add Next], 2nd Screen button will add a sample and will automatically jump the cursor to the next slot.
5. The memory bar chart will indicate the available project memory in tracker. This will depend on the type and size of samples selected and may limit the amount of instruments available in the instrument list.
6. Additional samples / instruments can be added. The instruments in the list will be available to add to a step.

Notes:

- A prompt will be offered if replacing an existing instrument.
- When navigating, the /.. symbol indicates folders and subfolder with a name. Selecting /.. alone will navigate up a level of the SD Card folder structure.
- Instruments have a .pti filename.
- The memory bar will show an additional red band (increases memory usage) or green band (decreases memory usage) indicating the potential memory impact when highlighting a sample / instrument to add. Should this be added to the instrument pool it will affect the memory usage as indicated by the red/green bar.

NOTES

DELETING AN INSTRUMENT FROM THE LIST

1. Press [Sample Loader] to open the sample browser and instrument list utility page.
2. Navigate to the central 'Instruments' window and highlight an existing instrument. If an existing instrument is highlighted it will be the one deleted in this process. Use [Shift] + Arrows to batch select multiple samples / instruments.
3. Press [Delete/Backspace].
4. A prompt asking if you want to continue on to delete the highlighted sample / instrument. Press [No], 7th Screen button to cancel without deleting or confirm deletion by pressing [Yes], 8th Screen button.
5. The instrument is removed from the list but is still present on the SD Card.
6. The memory bar chart will indicate the available project memory in tracker. This will depend on the type and size of samples selected and may limit the amount of instruments available in the instrument list.
7. Additional samples / instruments can be deleted. The instruments in the list will be available to use in the project.

DELETING ALL UNUSED INSTRUMENTS FROM THE LIST

1. Press [Sample Loader] to open the sample browser and instrument list utility page.
2. Navigate to the central 'Instruments' window.
3. Press [*Delete Unused*], 6th Screen button.
4. A prompt asking if you want to continue on to delete the highlighted sample / instrument. Press [No], 7th Screen button to cancel without deleting or confirm deletion by pressing [Yes], 8th Screen button.
5. Any instruments that are in the list but not used in the project are removed from the list. SD Card files remain intact.
6. The memory bar chart will indicate the available project memory in tracker. This will depend on the type and size of samples selected and may limit the amount of instruments available in the instrument list.

NOTES

IMPORTING TO THE PROJECT INSTRUMENT LIST

1. Press [Sample Loader] to open the sample browser and instrument list utility page.
2. Navigate to the left 'SD Card' window and navigate to and highlight a sample to import. Use the [Up] or [Down] or Turn (Jog) to navigate and Press [*Enter*] screen button to select folder.
3. Navigate to the central 'Instruments' window and highlight either an empty slot or an existing instrument. If an existing instrument is highlighted it will be replaced by the newly selected choice.
4. Press [*Import*], 5th Screen button. The sample is displayed for editing. Pressing [*Cancel*], 6th Screen button at any time to leave the import menu without importing.
5. The sample can have its start [*Start*], 2nd Screen button and end [*End*], 3rd Screen button adjusted. Select each an use (Jog) to adjust. This is a great feature when samples are too long or only a portion is needed.
6. Press [*Preview*], 1st Screen button to listen to the sample. The option to adjust the preview audio volume with, [*Preview Vol*], 7th Screen button.
7. When editing is complete, select an import option to load the sample into the instrument list:-
 - Press [*Import Low Quality*], 7th Screen button. This will import a lower quality sample. This will create a smaller file size and save memory. The trade off is audio sound quality reduction.
 - Press [*Import Normal*], 8th Screen button. This will import a sample at the normal Tracker quality specification. This will create a larger file size and take up more memory. The trade off is optimum audio sound quality.

Instruments can also be copied and pasted within the sample loader and instrument list browser to duplicate and instrument. Use the [Copy/Paste] dedicated button to undertake this task.

3.7 Summary of Configuration Options

A number of options can be set in the 'Config' menu. These defaults may be good enough to get started but specific changes may suit certain workflows and situations better. The details of these will be covered in relevant sections and only an overview of global settings is provided here.

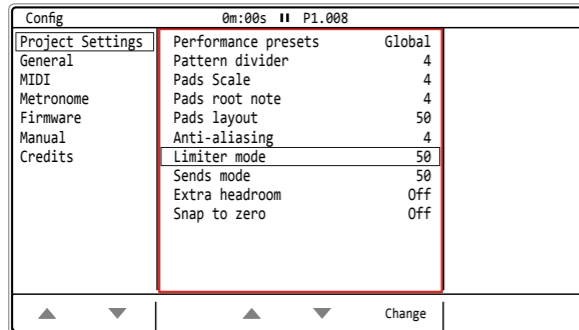

Press [Left] or [Right] to navigate between the option windows a red bounding box will indicate the selected window. Press [Up] or [Down] or Turn (Jog) to navigate to the desired listed option.

Also the [Up] and [Down] screen buttons will select the option and automatically select the menu window.

NOTES

Config Options

Menu	Option	Description	Book Section
Project Settings	Performance Presets	Allows performance presets to be saved either as a global configuration or local to each project.	Performance Mode
Project Settings	Pattern Divider	Sets the highlight level for the selected step offering better pattern visualisation.	Pattern Format
Project Settings	Pads Scale	Sets the scaling of the 4 x 12 grid pads when used for note playback / selection.	Sequencing Steps
Project Settings	Pads Root Note	Sets the root note between C2 - C4 of the bottom left pad in the 4 x 12 grid pad matrix.	Sequencing Steps
Project Settings	Pads Layout	Sets the note offset in semitones 1-12 for the pad located directly above the root note in pad grid.	Sequencing Steps
Project Settings	Anti-aliasing	Anti-aliasing set to 'On' gives a cleaner sound for sample playback. Off is more lo-fi vintage feel.	
Project Settings	Limiter Mode	Sets the characteristics of the limiter attack and release between subtle and extreme.	Master Effects
Project Settings	Sends Mode	Sets the sends to pre-fader i.e. independent of volume or post-fader.	Master Effects
Project Settings	Extra Headroom	Avoid clipping by adding extra headroom in the output audio.	
Project settings	Snap to Zero	Snap audio crossings to zero points, Used as green markers in the sample playback page.	Instruments
General	Radio Region	Sets the radio frequencies to match the geographic region, Europe, Australia, US, Japan.	Audio
General	Display Brightness	Adjusts the brightness level of the 7" display between three settings: High, Medium, Low.	System
General	Display Theme	The colour scheme of the screen. Original has the dark background while monochrome is bright.	System
General	Display Font	Text font option. Original has the classic consolas look while 'new' is smaller, more standard.	System
General	Pad Brightness	Adjusts the brightness of the 4 x 12 grid pads: High, Medium, Low.	System
General	Pads Preview	Allows the grid pads to be used to highlight notes in the active track or pattern lines in the grid editor.	

Menu	Option	Description	Book Section
General	Recording Options	Sets the options for what is recorded i.e. notes, quantization, micro-timing, velocity.	Sequencing Steps
General	Numbering Mode	Sets all numbers to the decimal starting at 0 or 1 or hexadecimal format. Classic look and feel.	System
General	Pattern Arrangement	Sets the pattern display to the traditional vertical original, vertical revolver or horizontal display.	Patterns
General	Pattern Top Info	Allows the top part of the pattern screen to display only the track name, additional info or off.	Patterns
General	Line In Channel	Selects the audio input of the line in between stereo, mono left or mono right.	Audio
MIDI	Clock In	Sets the source of the master clock, Internal (default) or external USB or MIDI In jack.	MIDI
MIDI	Clock Out	Sets the Tracker Mini clock output. Off, USB, MIDI Out jack, USB + MIDI Out jack.	MIDI
MIDI	Transport In	Sets the source of transport control commands, Internal (default) or external USB or MIDI In jack.	MIDI
MIDI	Transport Out	Sets the output of transport control commands, Off, USB, MIDI Out jack or USB+MIDI jack options.	MIDI
MIDI	Notes In	Sets the input routing of external notes in. Set to Off, USB, MIDI In jack or USB+MIDI jack options.	MIDI
MIDI	Notes Input Channel	Sets the MIDI channel for incoming notes from external gear. Select All channels or Ch 1-16.	MIDI
MIDI	MIDI Out	Sets the MIDI output routing between, Off, USB, MIDI Out jack or USB+MIDI jack options.	MIDI
MIDI	CC In	Sets CC (control change) input routing to Off, USB, MIDI In jack, USB+MIDI In jack.	MIDI
MIDI	CC In channel	Sets MIDI channel for CC (control change) incoming messages. Select All channels or Ch 1-16.	MIDI
MIDI	Middle C	Sets middle C as C-3, C-4, C-5, C-6. Calibrates range in Tracker with external gear.	MIDI
MIDI	Clock Sync Correction	Latency compensation for incoming sync. -6 to +6. Use with MIDI Jack or USB clock in.	MIDI

Menu	Option	Description	Book Section
Metronome	State	Turns the metronome on or off for live recording.	Projects
Metronome	Pre Roll	Provides a count in of 4 before starting to record.	Projects
Metronome	Time signature num	Upper numerator of the time signature	Projects
Metronome	Time signature denum	Lower denominator of the time signature	Project
Metronome	Volume	Volume level of metronome	Projects
Firmware	Firmware Update	Activates a firmware update based on the OS located on the SD card in the 'firmware' folder.	System
Firmware	Current version	Displays current version of installed OS. Visual indicator only.	System
Firmware	Build	Firmware build version display	
Firmware	Reset config	Resets this configuration menu to the default original settings.	System
Manual	--	Displays the quick start instructions, from the .jpg images located in the 'manual' folder of the SD card.	Architecture
Credits	--	Displays a list of people who supported the development of Tracker and associated elements.	

4

Pattern Format

Each project contains a maximum of 255 patterns across 8 tracks. Each pattern can hold up to 128 steps per track. Patterns are at the heart of Tracker and are built in the pattern sequencer. The sequencer is what makes Tracker different from normal digital audio workstations. Steps are the building blocks when creating patterns and by assembling these into audio arrangements it is possible to create beats and melodies. Each step consists of a note, instrument and two FX slots. These are triggered as each row is activated when playback is initiated. They can trigger audio information, effect actions or MIDI messages. Patterns are bite size elements of a full song and can be created as individual modules built using steps. Patterns are then combined and arranged together in song mode for chaining into a full length track. This section will focus on patterns using in audio tracks (although MIDI steps can be created together with

audio). This section will provide overall guidance on creating basic patterns as well as their structural elements generally. This is a foundation to patterns and a deeper dive into steps and sequencing comes next. All the basic building blocks and the process needed to get started in creating, editing and using a basic pattern are covered in this section. More advanced and in-depth elements of the components of a step are covered later as well as more advanced sequencing functions.

4.1 What's a Pattern?

Patterns are a combination of 8 Tracks where each has a series of steps mapped out. The steps form into a melody or beat. So for example Track 1 could be the Drums, Track 2 for Percussion, Track 3 as Bass etc. Patterns can be created using steps manually 'programmed' into the tracker or by recording in real time.

NOTES

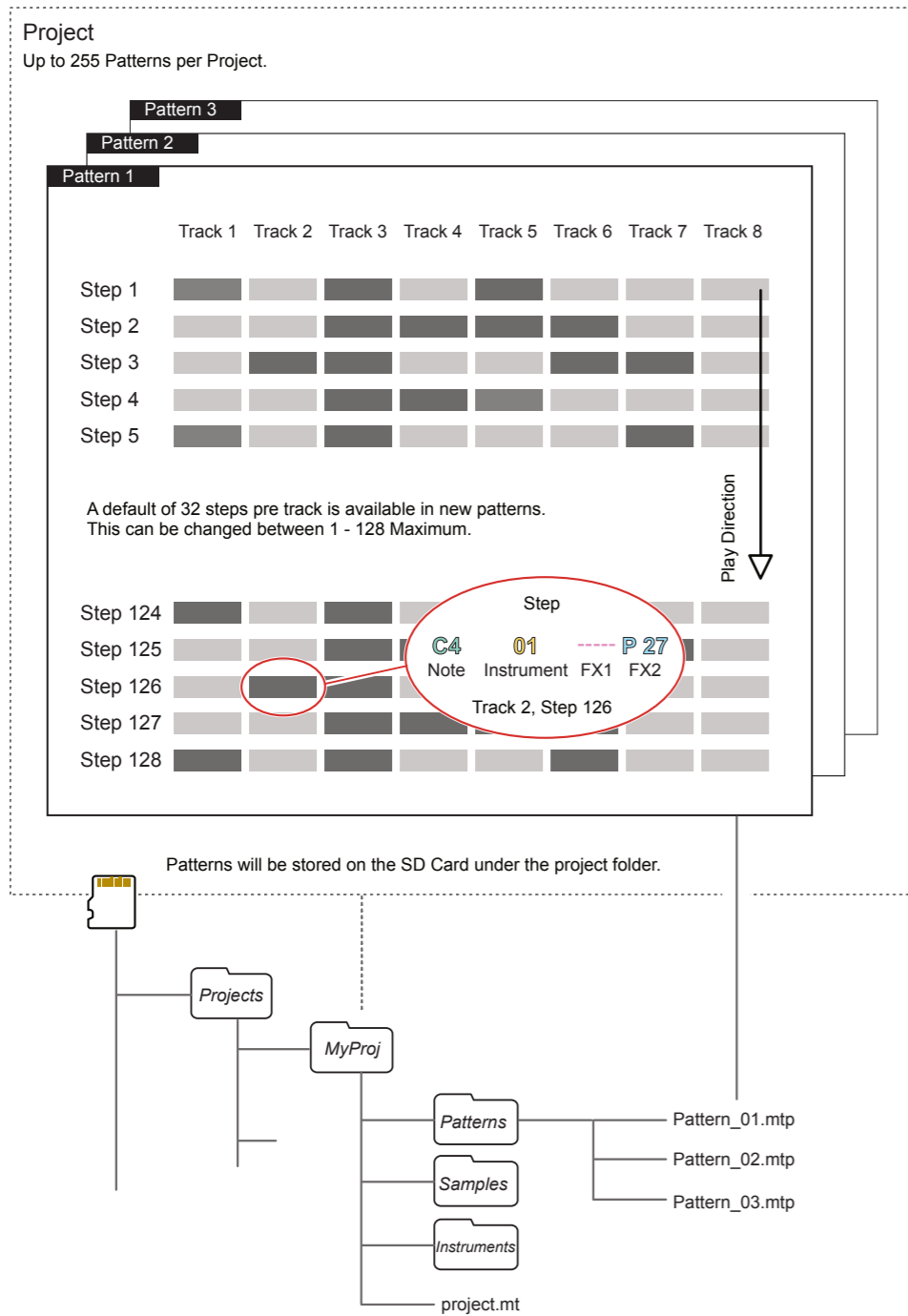

NOTES

4.2 Process of Creating a Pattern

Formatting and creating a pattern is a simple process but there are some good practices that will speed up workflow and help to move quickly to making music. A pattern is the container for steps and establishes the step timing and track format. The dynamic screen buttons are used heavily.

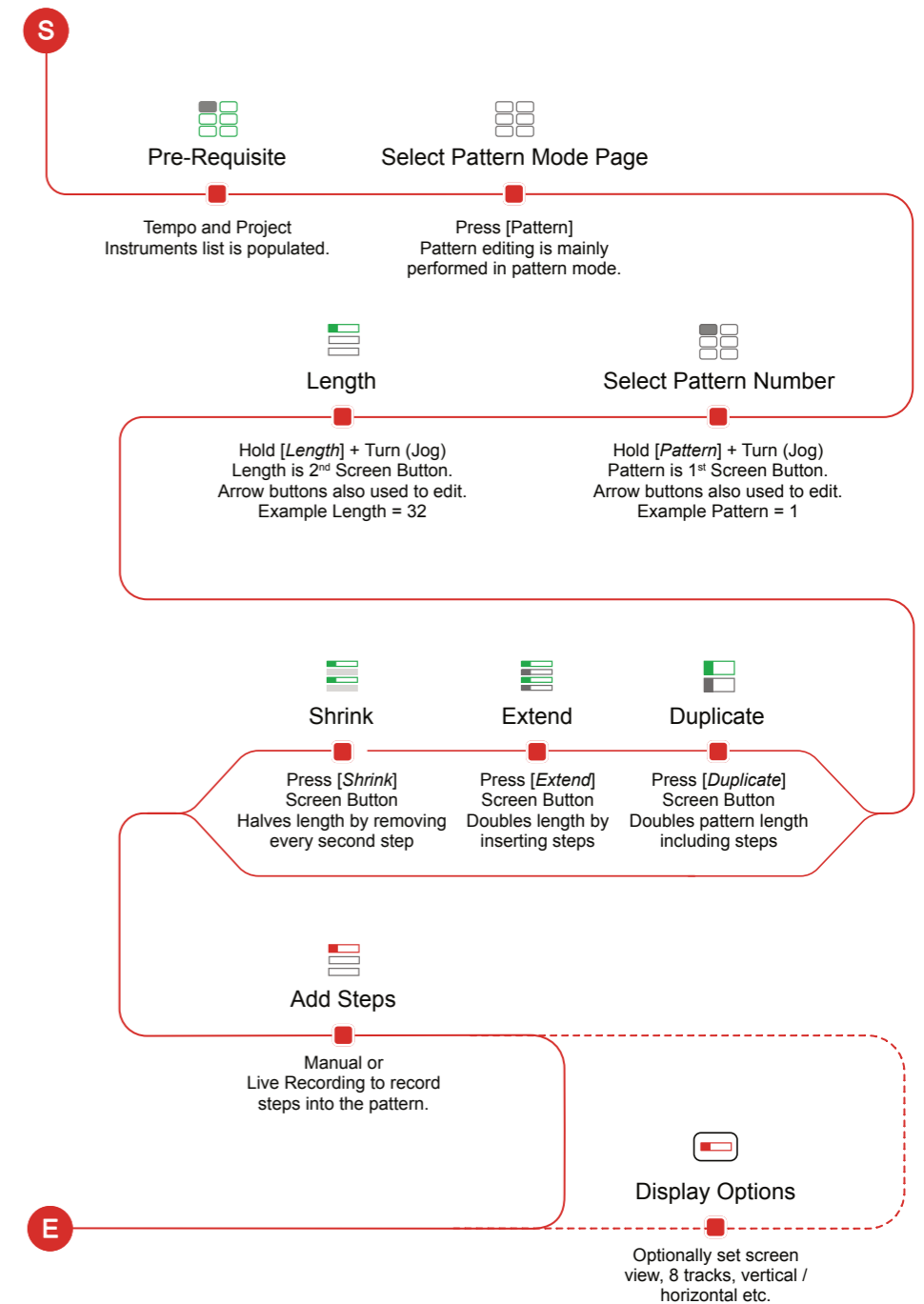

4.3 Configuring a Pattern.

Pattern and step editing is performed in 'Pattern' Mode. The first requirement is to create the pattern itself where steps can later be added to create the melody or beat. Commands for the pattern are available from the dynamic screen buttons located at the bottom of the page. These will change depending on the mode or selection made.

The dynamic screen buttons labeled at the bottom of the page will control options for creating patterns

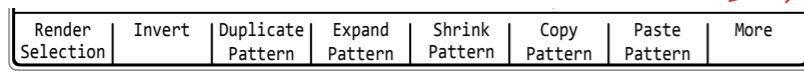
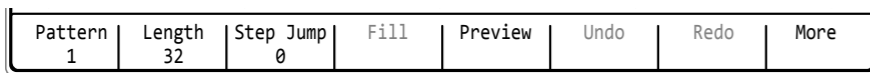

Menu Option	Function	Description
Pattern	Pattern Selection	Selects a pattern to edit. This will select a pattern number between 1-255 in the project.
Length	Pattern Length	Adjust the number of step rows in the pattern. Default is 32 but a maximum of 128 rows are available in a pattern.
Step Jump	Programming Aid	Assists in recording steps with the pads. Will automatically jump the selection cursor in defined steps.
Fill	Programming Aid	Assists in programming steps. Will automatically fill steps based on defined selection criteria
Preview	Instrument Preview	Will play the instrument for the step to allow previewing of the sound.
Undo	Undo Last Command	If available, will reset the previous state prior to the last action, effectively undoing the last (up to 20) commands.
Redo	Redo Last Command	If available, will restore the previous state after to the last action, effectively redoing the last (up to 20) commands.
More	Next Page	Selects the next page of commands - see below
Render Selection	Bounce Audio	Renders the selection to a new audio sample. Useful to use elsewhere or to reduce track consumption.
Invert	Invert Steps	Inverts all steps in the selection vertically
Duplicate Pattern	Extends Pattern	Extends the entire pattern and its associated steps, extending the pattern to double the length.
Expand Pattern	Extends Pattern	Extends the pattern by adding blank steps in between existing steps, extending the pattern to double the length.
Shrink Pattern	Contracts Pattern	Contracts the pattern length by deleting every 2nd step, reducing the pattern to half the length.
Copy Pattern	Copy	Copies the entire pattern to the virtual clipboard.
Paste Pattern	Paste	Pastes the copied pattern from the virtual clipboard into the location starting at the current position.
More	Prior Page	Selects the previous page of commands - see above

NOTES

NOTES

SELECTING THE PATTERN MODE PAGE

1. Press [Pattern] to select the pattern mode page.
2. The options for the pattern page will show at the bottom of the page and are represented by the 8 screen buttons.
3. To change the options page, Press [More], 8th Screen button. This toggles between the two pages of pattern options.

SELECTING A PATTERN

1. Press [Pattern] to select the pattern mode page.
2. Ensure options page 1 is displayed. Press [More] to toggle between the two pages of pattern options.
3. Hold [Pattern] - 1st Screen button + Turn (Jog). A pattern number between 1-255 can be selected. Blank patterns selected have 32 steps as default. Arrow buttons can be used instead of Jog.
4. The currently active pattern number is displayed top left in the info bar.

ADJUSTING THE PATTERN LENGTH

1. Press [Pattern] to select the pattern mode page.
2. Ensure options page 1 is displayed. Press [More] to toggle between the two pages of pattern options.
3. Hold [Length] - 2nd from left screen button + Turn (Jog). A pattern length between 1-128 steps can be selected. Default is 32. The arrow buttons can be used instead of Jog where [Left] or [Right] will set length in predefined denominations i.e. 1, 2, 4, 8, 16 etc

Tip: It is good practice to build patterns starting with a small length. For example start with 8 or 16 steps and create the beat or melody. This can then be duplicated / extended along with its steps and then edited to create longer passages.

NOTES

NOTES

EXTENDING PATTERN LENGTH

1. Press [Pattern] to select the pattern mode page.
2. Ensure options page 2 is displayed. Press [More] to toggle between the two pages of pattern options.
3. Press [Rec] to select recording mode and allow editing. Screen buttons will be unavailable, shown dim, otherwise.
4. The current pattern can be extended in several ways. The options available via the 8 screen buttons are:-
 1. Press [Duplicate Pattern]. The pattern will be extended by duplicating the full pattern along with its steps. Effectively doubles the pattern length.
 2. Press [Expand Pattern]. The pattern will be extended by inserting additional step rows in-between existing steps. Effectively doubles by stretching the pattern length.
 3. Adjusting [Length] will also increase the pattern length. New empty step rows added at the end.
5. The [Undo] or [Redo] screen buttons can be used if required to restore a previous state.

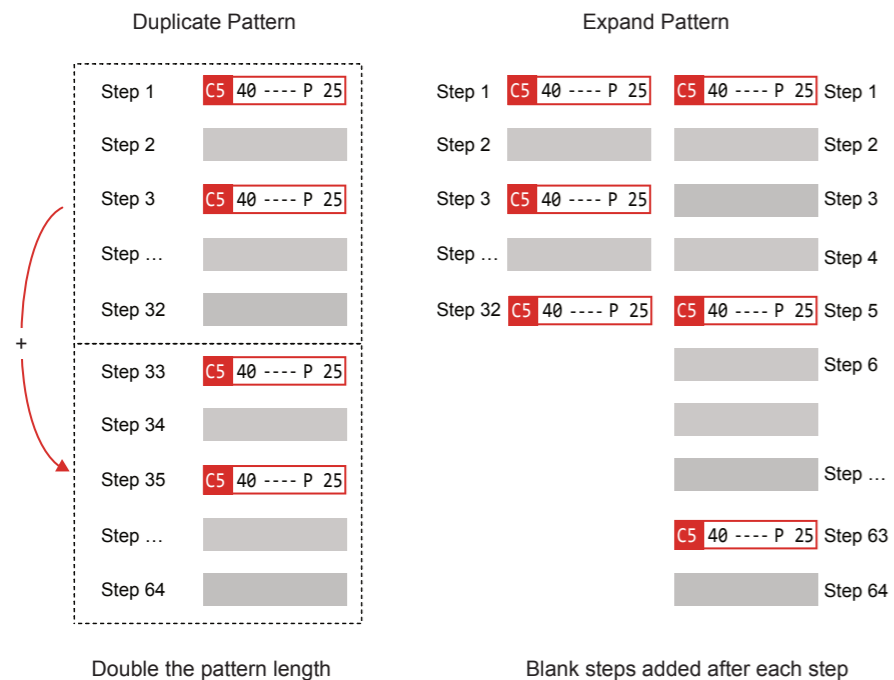

REDUCING PATTERN LENGTH

1. Press [Pattern] to select the pattern mode page.
2. Ensure options page 2 is displayed. Press [More] to toggle between the two pages of pattern options.
3. Press [Rec] to select recording mode and allow editing. Screen buttons will be unavailable, shown dim, otherwise.
4. The current pattern can be reduced in several ways. The options available via the 8 screen buttons are:-
 1. Press [Shrink Pattern]. The pattern will be reduced by deleting each second step in the pattern. This will delete any step whether empty or filled. Effectively halves the pattern length.
 2. Adjusting [Length] will also reduce the pattern length. Any steps will be hidden but will be restored if the pattern length is extended.
5. The [Undo] or [Redo] screen buttons can be used if required to restore a previous state.

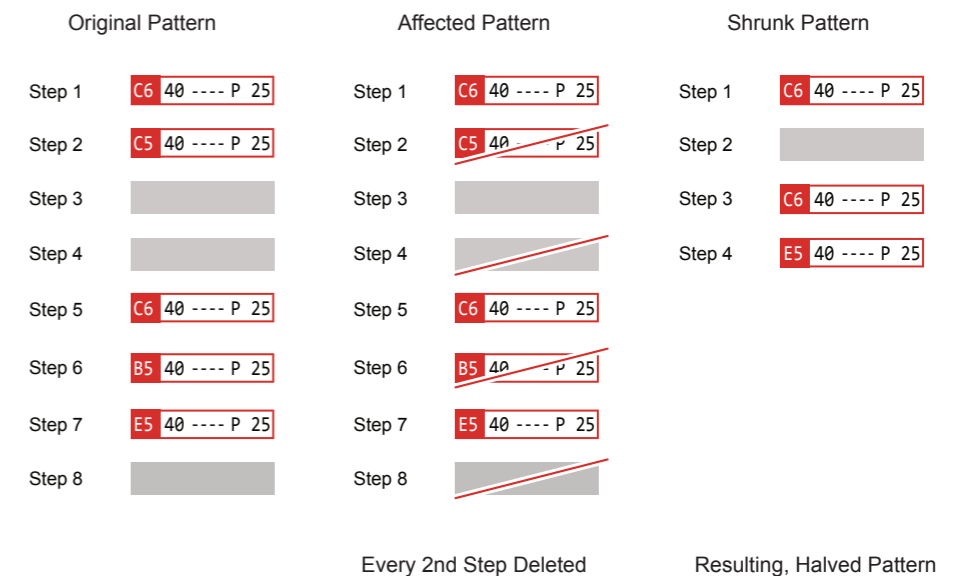

4.4 Copying and Pasting a Pattern.

Patterns can be copied and pasted between different pattern slots. This will copy the entire pattern and its steps as well as the length configuration.

COPYING AND PASTING A PATTERN

1. Press [Pattern] to select the pattern mode page.
2. The options on pages 1 & 2 are required during this process. Press [More] to toggle between the two pages of pattern options.
3. Press [Rec] to select recording mode and allow editing. Screen buttons will be unavailable, shown dim, otherwise.
4. On pattern page 1, select the pattern to copy, Hold [Pattern] 1st Screen button + Turn (Jog). Example, select Pattern 1.
5. On pattern page 2, Press [Copy] Screen Button. The pattern is copied to the clipboard.
6. On pattern page 1, select the pattern to paste into, Hold [Pattern] 1st Screen button, + Turn (Jog). Example, select Pattern 2.
7. On pattern page 2, Press [Paste] Screen Button. The pattern is pasted into the current pattern and will overwrite any existing data. It is possible to continue to paste the pattern to other pattern slots.
8. The [Undo] or [Redo] screen buttons can be used if required to restore a previous pattern state.

NOTES

4.5 Inverting a Selection of Steps.

Patterns are created top to bottom and steps assigned in the step rows. Steps once selected in a pattern can be inverted. This will reverse the order in which the steps play. For example the first step in the selection will play last and vice versa.

INVERTING A STEP RANGE IN A PATTERN

1. Press [Pattern] to select the pattern mode page.
2. Ensure options page 2 is displayed. Press [More] to toggle between the two pages of pattern options.
3. Press [Rec] to select recording mode and allow editing. Screen buttons will be unavailable, shown dim, otherwise.
4. Navigate to the first step. Press [Shift] + [Up] or [Down] to select the sequence of steps and / or Press [Shift] + [Left] + [Right] to select steps across tracks.
5. Press [Invert] Screen Button to reverse the order of the range of steps selected. This reverses the vertical order of the steps. The steps remain in their respective tracks.
6. The [Undo] or [Redo] screen buttons can be used if required to restore a previous state.



4.6 Pattern Mode Page Layout Options.

Pattern and step editing is performed in 'Pattern' Mode, selected by pressing the [Pattern] button. To edit steps, select [Rec]. The view in pattern mode can be changed in the config options.

Press [Shift] + [Insert / Home] to reset the cursor position to the start, step 1

Change the pattern info for the top bar in the Config settings: General > Pattern top info. Top bar: Off, Tracks Only or additional Info

The 'top down' view can be changed to 'left right' in the Config settings; General > Pattern Arrangement

Step Row

Pattern	Length	Step	Jump	Preview	Undo	Redo	More
1	32	0	11				

To select a step
Press [Up] or [Down] or Turn (Jog) to navigate vertically in the Tracker grid. Cursor will wrap past the end to the start when using arrow keys

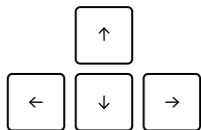

Press [Left] or [Right] to navigate horizontally in the Tracker grid

Switch to 8 Track view.
Displays a single element across all 8 tracks

Track 1	Track 2	Track 3	Track 4	Track 5	Track 6	Track 7	Track 8
---	C5	---	---	---	---	---	---
---	C5	C4	D2	---	---	---	---
---	---	C4	---	---	---	---	---

[Pattern] + [Note] - Displays all 8 tracks, with only the note parameters

[Pattern] + [Instrument] - Displays all 8 tracks, with only the instrument parameters

[Pattern] + [FX1] - Displays all 8 tracks, with only FX1 parameters

[Pattern] + [FX2] - Displays all 8 tracks, with only FX2 parameters

Hold [Pattern] + A combo of max 2 parameter buttons: Note, Instrument, FX1, FX2 to display 2 parameters per track across 8 tracks.

Press [Pattern] to return to 4 tracks, all step parameters

NOTES

NOTES

NAVIGATING THE PATTERN MODE EDITOR PAGE

1. Press [Pattern] to select the pattern mode page.
2. The step cursor will display a green border with the selected step parameter highlighted green in normal playback mode. This indicates the step in focus and current playhead position.
3. To move the position vertically, Press [Up] or [Down]. The selection will scroll and will wrap at the end of the pattern back to the top. Also Turn (Jog) to navigate up and down within the step range.
4. To move the position horizontally across tracks, or Press [Left] or [Right]. The selection will scroll across the 1-4 visible tracks and switch across tracks 5-8 at the right of the page. This view is default.
5. Press [Shift] + [Up], [Down], [Left] and [Right] to select rather than just navigate a range of steps.
6. To return the playhead / step selector to the top step 1 of the pattern, Press [Shift] + [Insert / Home] when the sequencer is stopped.

CHANGING FROM 4 TO 8 TRACK VIEW

1. By default the pattern page display 4 tracks. This can be changed to display 8 tracks with a various step options:-
 - 8 Tracks with only Note parameter: Press [Pattern] + [Note].
 - 8 Tracks with Instrument parameter: Press [Pattern] + [Instrument].
 - 8 Tracks with only FX1 parameter: Press [Pattern] + [FX1].
 - 8 Tracks with only FX2 parameter: Press [Pattern] + [FX2].
 - 8 Tracks with 2 selected parameters: Press [Pattern] + [P1] + [P2], where 'P1' and 'P2' are 2 from; [Note], [Instrument], [FX1], [FX2].
 - Revert to 4 track mode, Press [Pattern]

NOTES

CHANGING BETWEEN VERTICAL AND HORIZONTAL VIEW MODE

1. The default mode is for Tracker to display patterns top to bottom in a vertical arrangement. This is the traditional and expected view for trackers in general. This can be changed to an Horizontal left to right view. This is less common but may suit people more accustomed to more modern DAW arrangements.
2. Press [Config] to open the project configuration menu.
3. Ensure the left window is highlighted red i.e. in focus. Navigate windows by pressing [Left] or [Right]. Menu windows will automatically be selected when pressing the relevant screen keys below the window to navigate [Up] or [Down].
4. Press [Up] [Down] or Turn (Jog) to highlight with the bounding box the 'General' option. Alternatively press the relevant screen keys below the window to navigate [Up] or [Down].
5. Highlight red the General options window. Navigate windows by pressing [Left] or [Right]. Menu windows will automatically be selected when pressing the relevant screen keys below the window to navigate [Up] or [Down].
6. Press [Up] [Down] or Turn (Jog) to highlight with the bounding box over the 'Pattern Arrangement' option. Alternatively press the relevant screen keys below the window to navigate [Up] or [Down].
7. To change the options between horizontal and vertical views, Press [Change]. The parameter pop-up window listing the available options will appear.
8. Turn (Jog) or Press [Up] / [Down] or [Up] / [Down] Screen Buttons to highlight the desired option.
 - Vertical - Tracks scroll top to bottom (default).
 - Horizontal - Track scrolls left to right.
9. Press [Apply] - 6th from left screen button to confirm selection or [Cancel] - 3rd from left screen button to exit without changing.
10. The display will reflect the selected option.

NOTES

CHANGING PATTERN TOP INFO DETAILS

1. The default mode is for Tracker to display an information bar plus the tracks at the top of the pattern display. This can be changed to give more clarity to the tracker pattern grid.
2. Press [Config] to open the project configuration menu.
3. Ensure the left window is highlighted red i.e. in focus. Navigate windows by pressing [Left] or [Right]. Menu windows will automatically be selected when pressing the relevant screen keys below the window to navigate [Up] or [Down].
4. Press [Up] [Down] or Turn (Jog) to highlight with the bounding box the 'General' option. Alternatively press the relevant screen keys below the window to navigate [Up] or [Down].
5. Highlight red the General options window. Navigate windows by pressing [Left] or [Right]. Menu windows will automatically be selected when pressing the relevant screen keys below the window to navigate [Up] or [Down].
6. Press [Up] [Down] or Turn (Jog) to highlight with the bounding box over the 'Pattern Top Info' option. Alternatively press the relevant screen keys below the window to navigate [Up] or [Down].
7. To change the select between horizontal and vertical views, Press [Change]. The parameter pop-up window listing the available options will appear.
8. Turn (Jog) or Press [Up] / [Down] or [Up] / [Down] Screen Buttons to highlight the desired option.
 - Off - No information is displayed at the top of the page.
 - Track Info Only - Only display the track number / name information.
 - Additional Info: Display tracks, and upper bar expanded information, such as time, transport, pattern, instrument etc. This is default.
9. Press [Apply] - 6th from left screen button to confirm selection or [Cancel] - 3rd from left screen button to exit without changing.
10. The display will reflect the selected option.

NOTES

NOTES

CHANGING THE PATTERN GRID VISUAL DIVIDERS

The pattern grid has a number of graphic guides as a visual aids when sequencing steps into a pattern. This is by default set to divisions of 4 providing a visual on beat guide at rows 1, 5, 9 etc. These can be changed in the 'Config' menu settings.

1. Press [Config] to open the project configuration menu.
2. Navigate to 'Project Settings' option. Navigate windows by pressing [Left] or [Right]. Menu windows will also be automatically be selected when pressing the relevant screen keys below the menu window to navigate [Up] or [Down].
3. In the project setting options, central window, highlight 'Pattern Divider'.
4. Press [Change] - 6th from Left Screen Button.
5. Turn (Jog) or Press [Up] / [Down] or [Up] / [Down] Screen Buttons to highlight the desired option between 1 - 16.
6. Press [Apply] - 6th from left screen button to confirm selection or [Cancel] - 3rd from left screen button to exit without changing.
7. The display will reflect the new visual indicator divider bars.

Pattern Divider Setting in 'Config' Menu under 'Project Settings'

Pattern 1			
1	C5 40	----	P-25
2	C5 40	----	P-25
3	-----	-----	-----
4	-----	-----	C3 04
5	C5 M02	----	P 25
6	-----	-----	-----
7	-----	-----	-----
8	-----	-----	D3 04
9	-----	-----	-----
10	-----	-----	D3 04
11	-----	-----	-----
12	-----	-----	D3 04
13	-----	-----	-----
14	-----	-----	-----
15	-----	-----	-----
Pattern	Length	Step	Jur
1	32		0

Pattern 1			
1	C5 40	----	P-2
2	C5 40	----	P-2
3	-----	-----	-----
4	-----	-----	-----
5	C5 M02	----	P 2
6	-----	-----	-----
7	-----	-----	-----
8	-----	-----	-----
9	-----	-----	-----
10	-----	-----	-----
11	-----	-----	-----
12	-----	-----	-----
13	-----	-----	-----
14	-----	-----	-----
15	-----	-----	-----
Pattern	Length		
1	32		

Pattern 1			
1	C5 40	----	----
2	C5 40	----	----
3	-----	-----	-----
4	-----	-----	-----
5	C5 M02	----	----
6	-----	-----	-----
7	-----	-----	-----
8	-----	-----	-----
9	-----	-----	-----
10	-----	-----	-----
11	-----	-----	-----
12	-----	-----	-----
13	-----	-----	-----
14	-----	-----	-----
15	-----	-----	-----
Pattern	Leng		
1	32		

Visual Dividers to aid step positioning. Default shown = 4.

Pattern Divider. Example = 3.

Pattern Divider. Example = 7.

EDITING TRACK NAMES

Track names can be edited and changed to custom text. Track name length is maximum 7 characters. The defaults are Track 1, Track 2, Track 3 etc but can be set to more appropriate names such as drums, perc, bass etc.

1. Press [Master] to select the master mode page. This consists of 3 pages and each is cycled in turn by pressing [Master] button. Page is displayed top bar, left side.
2. Navigate to page 2/3 - Track Mixer. All tracks are displayed in this view.
3. Press [Rec] and the editing mode will be toggled on or off. Set to on, as indicated by the word 'Edit' in red at the bottom of each track and representing the screen buttons per track.
4. Press the relevant screen button 1 - 8 for the track to edit. For example, Press Screen Button for Track 1 - 1st Button on the left.
5. The Alpha numeric QWERTY keyboard will be displayed and enable the default 'Track 1' name to be changed. Edit as per normal using the QWERTY functions with the pads or navigation arrows and screen button commands. Maximum 7 characters available for track names.
6. Press [Save], 8th Screen button, to confirm and immediately save the new name for the track.
7. Repeat step 4 - 6 for other tracks if required.

Track Mixer 2/3							
0m:00s				P1.008			
Kick	Drums	Perc	Bass	Lead	Pad	Track 7	Track 8
0.00 dB	0.00 dB	0.00 dB	0.00 dB	0.00 dB	0.00 dB	0.00 dB	0.00 dB
Edit	Edit	Edit	Edit	Edit	Edit	Edit	Edit



Press [Rec] to toggle the track name editor on or off on the [Master] Page 2/3. Press a screen button 1 - 8 to select the specific track to edit.

4.7 Quick Start Step Creation.

Patterns are just empty containers and will require steps to be added to create a beat of melody. A step is essentially a note, instrument (based on a sample) and two effect slots. This section gives a quick start on step composition before moving to more in depth coverage in a future section.

■ ADDING STEPS IN A PATTERN

1. Press [Pattern] to select the pattern mode page.
2. To move the position vertically, Press [Up] or [Down] or Turn (Jog). To move the position horizontally across tracks, or Press [Left] or [Right]. Ranges can be selected using [Shift] + (Jog) or Arrow Buttons.
3. Select recording mode, Press [Rec]. The steps selected will appear red as opposed to green when in normal playback mode.
4. To add a step, Hold the dedicated step function button and set the step using the grid pads or the jog wheel.
 - Hold [Note] + [PAD] or Turn (Jog). Adds a note value to the step.
 - Hold [Instrument] + [PAD] or Turn (Jog). Adds an instrument from the instrument list. This will require instruments to be available in the instrument list. Default notes are also assigned.
 - Hold [FX1] + [PAD] or Turn (Jog). Adds an effect from the effect list to the step
 - Hold [FX2] + [PAD] or Turn (Jog). Adds an effect from the effect list to the step
5. Subsequently pressing [PAD] will add a step based on the selected parameter and pad selected.
6. Pressing [Rec] + [Play] will allow live recording of adding steps.

NOTES

NOTES

■ EDITING EXISTING STEPS IN A PATTERN

1. Press [Pattern] to select the pattern mode page.
2. To move the position vertically, Press [Up] or [Down] or Turn (Jog). To move the position horizontally across tracks, or Press [Left] or [Right]. Ranges can be selected using [Shift] + (Jog) or Arrow Buttons.
3. Select recording mode, Press [Rec]. The steps selected will appear red as opposed to green when normal playback mode is set.
4. To edit a step, press the dedicated step function button i.e. [Note], [Instrument], [FX1], [FX2] and the selection will highlight the parameter in the step selection bounding box.
5. Turn (Jog) to change the selected parameter for the current step.

■ DELETING STEPS IN A PATTERN

1. Press [Pattern] to select the pattern mode page.
2. To move the position vertically, Press [Up] or [Down] or Turn (Jog). To move the position horizontally across tracks, or Press [Left] or [Right].
3. Ensure a note or instrument parameter is selected. Deleting when the FX1 or FX2 parameter is selected will only delete the FX parameter setting and not the full step. MIDI Instruments would need the parameter deleting specifically
4. Press [Delete/Backspace]. The selected step or step range will be deleted from the pattern.

■ INSERTING STEPS IN A PATTERN

1. Press [Pattern] to select the pattern mode page.
2. To move the position vertically, Press [Up] or [Down] or Turn (Jog). To move the position horizontally across tracks, or Press [Left] or [Right].
3. Press [Insert / Home]. A new empty step row is added and the selected step and steps below are moved down.

5

Sequencing Steps

Steps and patterns go hand in hand. The earlier Pattern Format section covered the general pattern creation, structure and general navigation of patterns. Also the process of adding and editing steps at a fundamental level. This section goes further into the workflow and process of sequencing steps and takes a deeper dive and more advanced view. The four components of a step; Note, Instrument, FX1 and FX2 are explained in more detail, giving an insight into what's behind each one. The multiple options in the process of working with steps as well as the detailed explanations such as how to create an instrument or what each effect does are included. Steps can be used for melodies beats and with multiple tracks can create chords. The focus here will be on the audio elements of steps with MIDI specifically covered in more detail in a later section although a similar process applied to both. The

section has a heavy focus on the process and techniques associated with working with steps in patterns. The included workflow tools and tips will speed up the process of creating patterns and making music and help to become more comfortable in using Tracker.

5.1 Dedicated Step Parameter Buttons.

A step is a building block which triggers events such as playing a note or beat or activating a MIDI action and is used for creating patterns. Steps are programmed across pattern rows which represent each of the eight available tracks in the pattern sequence.

A step is a combination of 4 main components each of which has a dedicated selection button:-

- Note.** This sets the pitch of the step and is important for creating melodies or beats based on sample mapped drum hits.
- Instrument.** This is a combination of a sample and the parameters and settings assigned to it. Also for setting MIDI Channel.
- FX1.** The first effect slot where the modulation and audio effects can be applied for the step.
- FX2.** The second effect slot where the modulation and audio effects can be applied for the step.

Step Dedicated Parameter Buttons

Pattern page is selected by pressing [Pattern] while the Note, Instrument, FX1 and FX2 have dedicated buttons for editing the selected step.

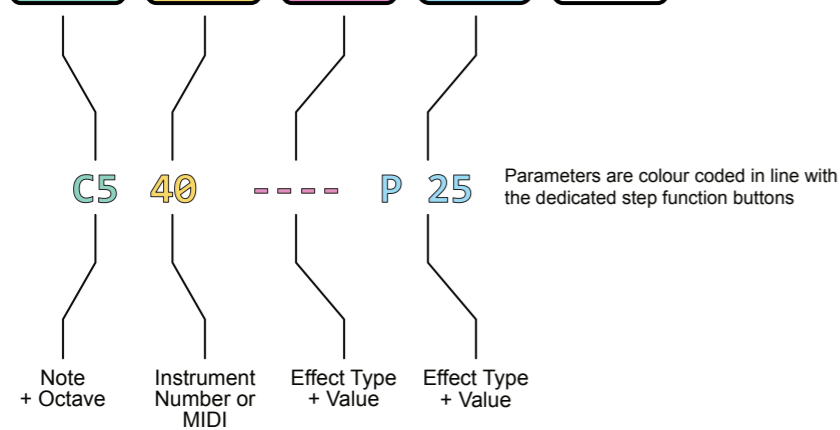

NOTES

5.2 Process of Creating a Step

Steps are sequenced in the Tracker each of which contains a Note, Instrument, and two FX slots options. It is good practice to structure these into tracks of relevance. For example kick drum on track 1, especially at the starting point.

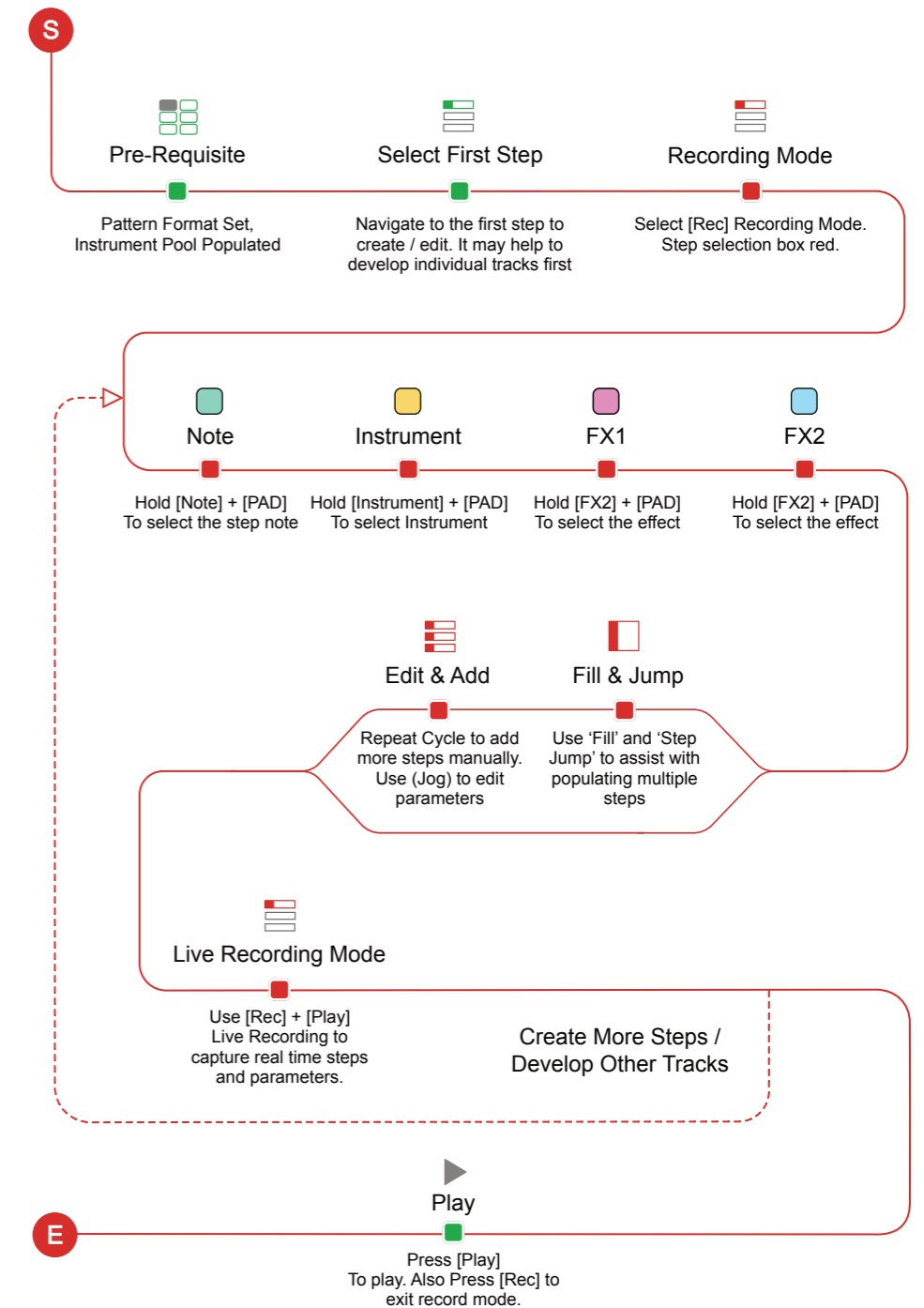

NOTES

5.3 Recording Mode.

Steps are created by recording into the Pattern grid. There are two methods of recording steps, firstly by manually programming steps at desired intervals per track, some automated features will help in the workflow. Also real time live recording is possible using the 4 x 12 grid pads.

The selected step is navigated using the arrow keys and jog wheel. An active step will have at least one of the four; note, instrument, FX1, FX2 elements shown. The currently selected step will have a green bounding box displayed.

The selected step to edit in recording mode will be shown with a red bounding selection box. Note that navigation functions will become edit functions when in recording mode.

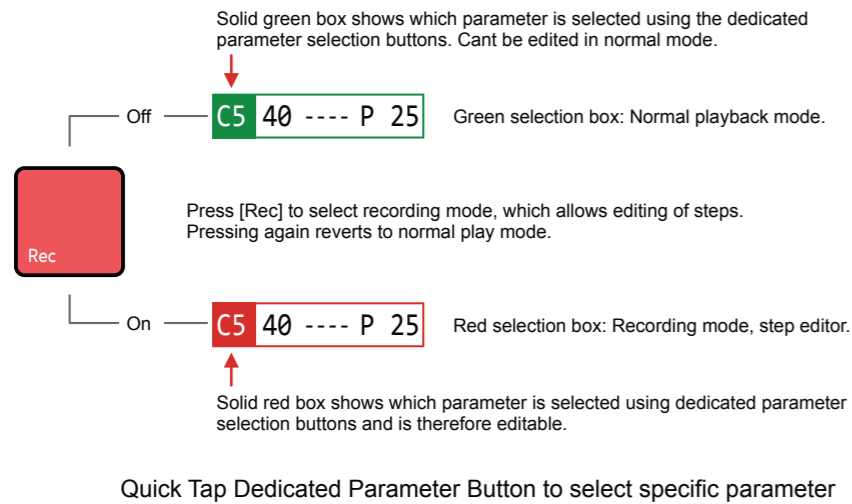

TOGGLING RECORDING MODE ON/OFF

1. The default mode is for Tracker to play patterns and the currently selected step indicated by the green bounding box.
2. Press [Rec] to toggle between playback and recording mode. Recording mode is required to create, edit and configure steps in a pattern. The bounding box is indicated red in recording mode.
3. (Jog) wheel navigation function will become an edit function in recording mode. Any selected parameter - solid colour, can be changed in recording mode with the jog wheel.
4. Hold the dedicated parameter button: Note, Instrument, FX1 or FX2 to temporary select for choosing an option or quick tap to lock selection.

NOTES

5.4 Manual Recording Steps.

Steps can be added manually in Pattern Mode by navigating to a location and using the dedicated step parameter buttons. Pre-requisite is that the project instrument list is pre-populated with sample / instrument options.

MANUALLY ENTERING AND EDITING A STEP

1. Press [Pattern] to select the Pattern Mode page.
2. Select the target step to edit. Use [Up], [Down] or Turn (Jog) to scroll top to bottom. Press [Left], [Right] to select a track. Example Row 1 of Track 1. The step should be highlighted with the green bounding box.
3. Press [Rec] to switch to recording mode.
4. Press [Preview] - 5th Screen Button to listen to the step audio.
5. The Jog function will now change the selected parameter when in recording mode as opposed to purely navigation in normal play mode.
6. The step editing intervals will depend on the 'Step Jump' setting. Step Jump set to 0 will keep the current step active after adding, Set to 1 will move to the next row to allow faster population of a series of steps.
7. Hold the dedicated parameter keys + Pad / Jog / Arrows to set each of the step parameters. Tap the dedicated Parameter Button to lock its selection and avoid the necessity of keeping hold of the button:-
 - Note: Hold [Note] + [PAD] to set a note for the step. With the note already selected, Turn (Jog) to change it's value. Hold & release [Note] will set an empty step to default note i.e. C0.
 - Instrument: Hold [Instrument] + [PAD] to set from the instrument list. Also with instrument already selected, Turn (Jog) to change it. Hold & release [Instrument] will set the step to the prior selection.
 - FX1: Hold [FX1] + [PAD] to set the FX from the effect list. Also with [FX1] already selected, Turn (Jog) to change it's value. Hold & release [FX1] alone will set an empty step to the same effect type as previously selected but with a randomly applied value.
 - FX2: Hold [FX2] + [PAD] to set the FX from the effect list. Also with [FX2] already selected, Turn (Jog) to change it's value. Hold & release [FX2] alone will set an empty step to the same effect type as previously selected but with a randomly applied value.
8. Pressing a [PAD] will now record a steps, parameter and value.

NOTES

Manual Step Entry

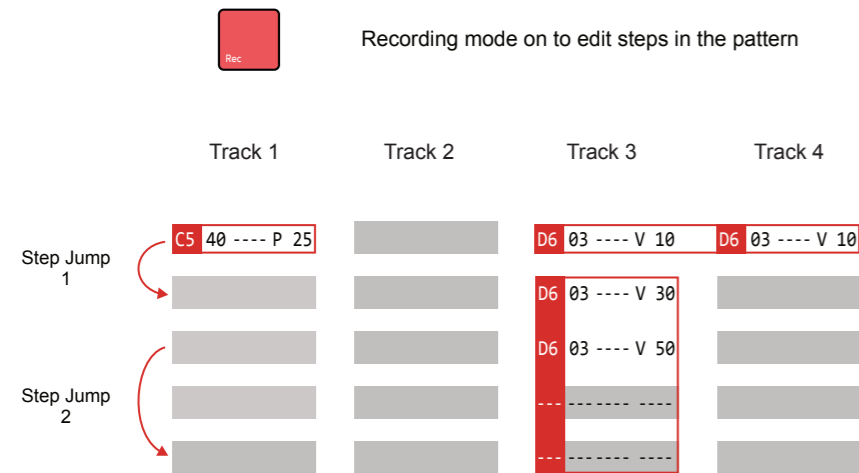

Steps can be added individually.
Example: Hold [Note] + [PAD] to select an option.

Subsequent steps are recorded when pressing pads.
This will record iteratively the selected parameter into rows defined by the 'Step jump' intervals.

Select multiple step rows with [Shift] + [Up] or [Down].
Also across multiple tracks [Shift] + [Left] + [Down]

On the top row [Shift] + [Up] will select all steps in the track. Press [Shift] + [Up] + [Up] to select all steps.

Edits to any existing parameters can be made simultaneously, but only if a parameter is already set. These changes will be relative to the original value. Unassigned elements of a step will remain empty.

Playing [PAD] in recording mode will record the respective parameter value depending on 1) the parameter selected for the step and 2) the actual pad number chosen.

Example shows Pad 2 selected.

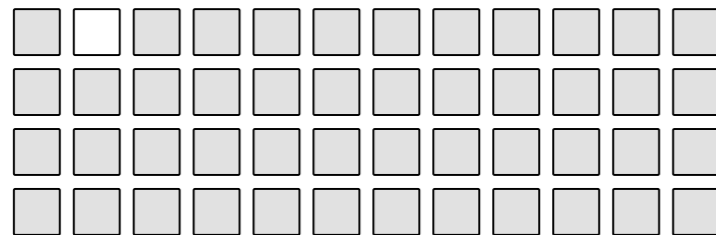

- D6 03 ---- V 50** Note Selected, Pad 3 which represents D6.
- D6 03 ---- V 50** Instrument Selected, Pad 3 which represents Instrument #3.
- D6 03 ---- V 50** FX1 Selected, FX Effect not applied.
- D6 03 ---- V 50** FX2 Selected, Pad 3 which represents effect #3 - Volume = 50.

Quick Tap Dedicated Parameter Button to lock the selection e.g. [Instrument]

NOTES

NOTES

Steps can be added edited collectively too. Select a range within a track or across tracks to edit.

MANUALLY EDITING A RANGE OF STEPS

1. Press [Pattern] to select the Pattern Mode page.
2. Select the target step to edit. Use [Up], [Down] or Turn (Jog) to scroll top to bottom. Press [Left], [Right] to select a track. Example Row 1 of Track 1. The step should be highlighted with the green bounding box.
3. Press [Shift] + [Left] or [Right] to select across tracks and [Shift] + [Up] or [Down] to select rows in a track and expand the selection range.
4. To select all steps for a track, select the top step on the track to select, then Press [Shift] + [Up].
5. To select all steps in the pattern, select the top step on a track, then Press [Shift] + [Up] + [Up].
6. Press [Rec] to switch to recording mode. The step bounding box will turn red and allow editing of the collective step range.
7. Press [Preview], 5th Screen button, to play only the range of selected steps. Also press a [PAD] to preview.
8. The Jog function will now change the selected parameter when in recording mode as opposed to purely navigation in normal play mode.
9. Select a parameter to edit. Only existing parameters can be changed. Any empty parameter slots will not change and remain open.
 - To select Note: Hold [Note] + Select, or Tap [Note] to lock.
 - To select Instrument: Hold [Instrument] + Select or Tap [Instrument] to lock selection of parameter.
 - To select FX1: Hold [FX1] + Select or Tap [FX1] to lock selection.
 - To select FX2: Hold [FX2] + Select or Tap [FX2] to lock selection.
10. Turn (Jog) to adjust the parameter value of the selected parameter within the step. Selected parameter will be solid coloured red. When adjusting simultaneous values they will each change relative to the original value.

COPYING AND PASTING STEPS AND STEP RANGES

1. Press [Pattern] to select the Pattern Mode page.
2. Navigate to select a Step. Also Press [Shift] + [Left] or [Right] and [Shift] + [Up] or [Down] to select tracks and rows.
3. Press [Rec] to switch to recording mode. The step bounding box will turn red and allow copying of the step or collective step range.
4. Press [Copy/Paste] button. The selected step or step range will be copied to the clipboard.
5. Relocate the cursor to the first step in which to paste by using [Up], [Down], Left] or [Right].
6. Press [Shift] + [Copy/Paste] button. The copied step or step range will be pasted into the selected step and the relative range. Undo and Redo can be used if needed.

DELETING STEPS AND STEP RANGES

1. Press [Pattern] to select the Pattern Mode page.
2. Navigate to select a Step. Also Press [Shift] + [Left] or [Right] and [Shift] + [Up] or [Down] to select tracks and rows.
3. Press [Rec] to switch to recording mode. The step bounding box will turn red and allow copying of the step or collective step range.
4. Press [Delete/Backspace] button. The selected step, if note or instrument is selected, will be deleted. If FX1 or FX2 is only selected then the effect alone is deleted.
5. Note that MIDI values are not be delete when deleting a not, but can be deleted when the instrument parameter is selected.

COPY / PASTE AN ENTIRE PATTERN

1. Press [Pattern] to select the Pattern Mode page.
2. Hold [Pattern] + [Copy/Paste] to copy the current pattern.
3. Select a new pattern, Press [Pattern] + [Up] or [Down]
4. Hold [Pattern] + [Shift] + [Copy/Paste] to paste into the current pattern.

NOTES

NOTES

5.5 Step Jump Recording Multiple Steps

When steps are added using a [PAD] the active step is automatically advanced to the next step when complete. The intervals for this are based on the 'Step Jump' feature. This is useful for creating patterns with defined intervals and speeding up workflow.

Step Jump Examples

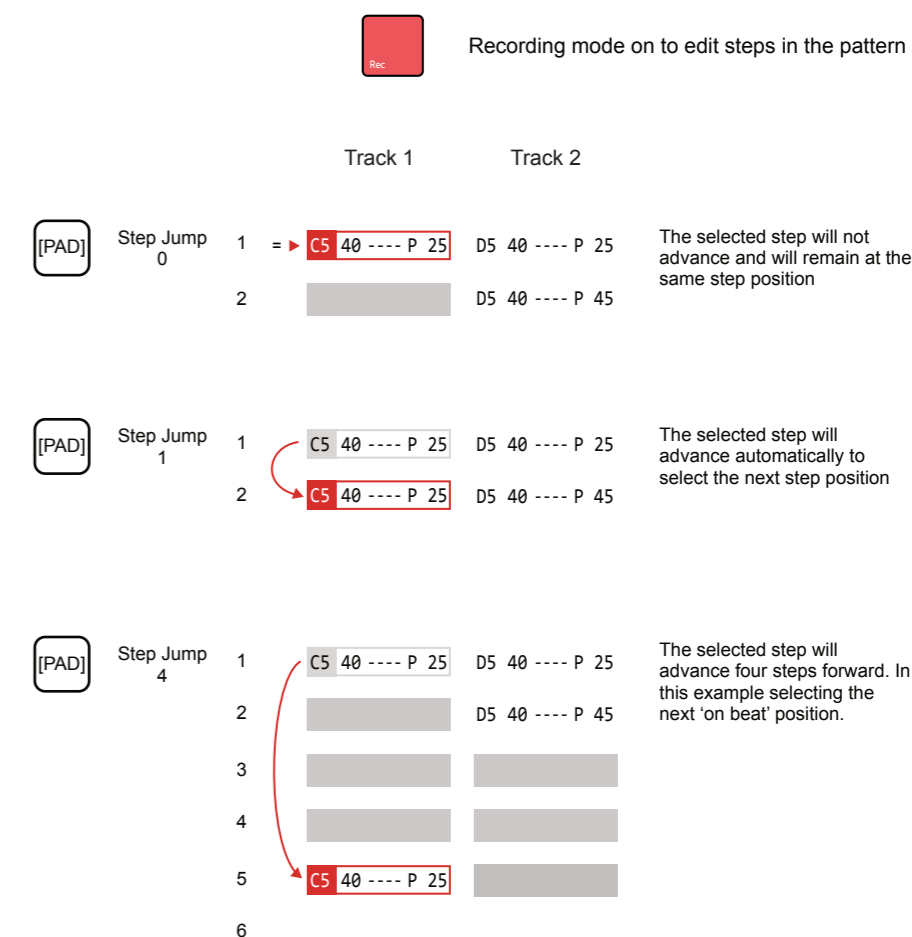

The Step Jump setting is useful when populating specific intervals, for example each on beat step or each off beat step or alternate steps for percussion. This speeds up the workflow and helps in creating interesting sequences.

ENTERING STEPS WITH STEP JUMP

1. Press [Pattern] to select the Pattern Mode page.
2. Navigate to select a Step.
3. Press [Rec] to switch to recording mode. The step bounding box will turn red and allow steps to be added.
4. Hold [Step Jump], 3rd Screen button + Turn (Jog). Set the value to the step jump interval required.
5. Pressing a [PAD] will enter a step and advance the active step by the value set in the 'Step Jump' setting.
6. Continue to press [PAD] to add more steps and advance by the set interval or edit the current step manually.

NOTES

5.6 Fill Recording Multiple Steps

The 'Fill' function allows a more elaborate and detailed population of step ranges. This speeds up workflow by helping to create batches of steps with defined criteria automatically applied. Also Fill is a very creative tool for generating melodies and beats and experimenting with patterns.

It is possible to fill ranges that are already containing steps, contain empty steps or mix of both. The fill operates in the range and ignores the Step Jump parameter.

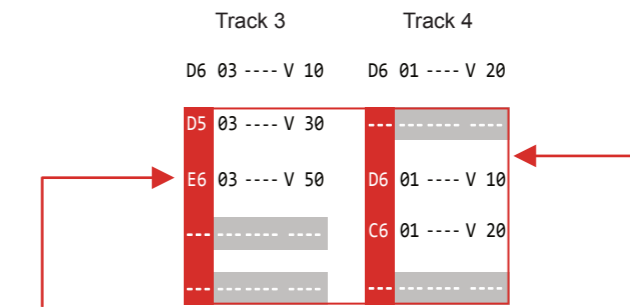

Fill Parameter
The selected parameter will be the element to be filled.
Example: Illustration shows Note selected

Range To Fill
Fill will populate a selected range of steps based on the fill criteria applied.
Example: Illustration shows 2 Tracks, 4 rows.

ACCESSING THE FILL UTILITY

1. Press [Pattern] to select the Pattern Mode page.
2. Press [Rec] to switch to recording mode. The step bounding box will turn red and allow editing of steps.
3. Select a range of steps: Hold [Shift] + [Up], [Down], [Left] or [Right]
4. Ensure the step parameter to populate is selected: Press [Note], [Instrument], [FX1] or [FX2]. The parameter will be highlighted solid red.
5. Press [Fill], 4th Screen button. This will open the Fill utility pop-up window and be ready to select the criteria to apply to the selected step range and its selected parameter.

NOTES

Fill Utility Window

The window layout is similar for the step range and parameters selected. However the content and features for fill will change depending on the context of the selection and the options chosen. A typical Fill window is shown below with a summary of common features. The Fill utility is mainly controlled using the dynamic screen buttons under the Tracker screen.

To access Fill:-

Press [*Fill*] - Screen Button, when in [Rec] Mode of the [Pattern] Page.

Dynamic area of 5 features containing the criteria specifically required for 1) Parameter selected, 2) Step range selected and 3) Options chosen in 'Where' & 'Fill Type'.

Example Illustration shows a range of notes selected with the 'note' and 'constant' selections.

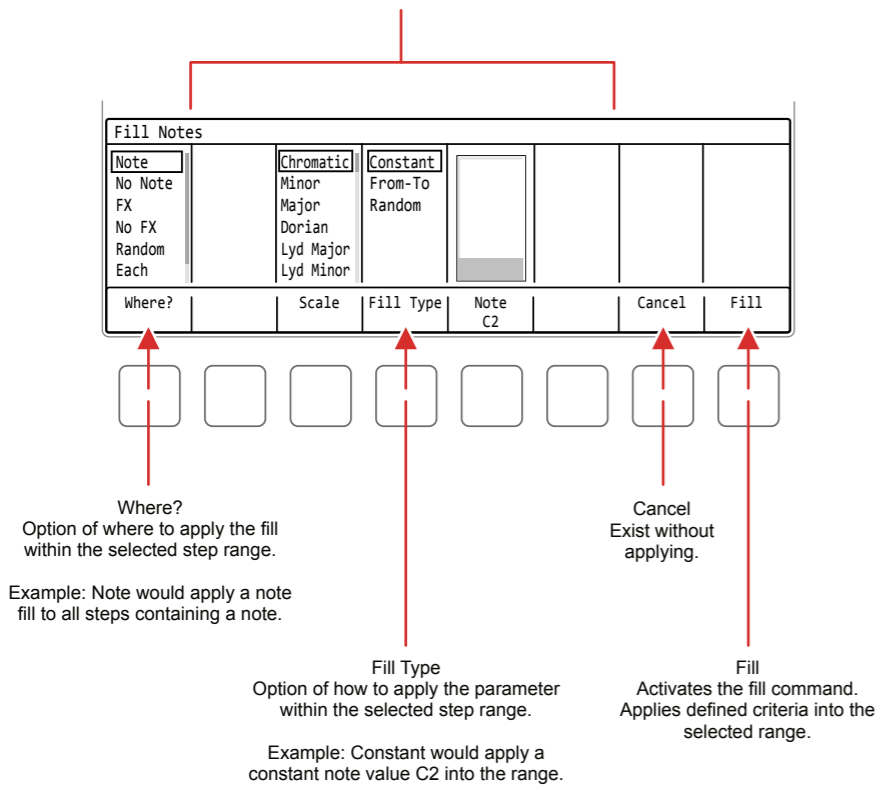

Ensure a range of steps is selected and the step parameter also selected before opening the Fill utility. This range and parameter will be what determines the fill application.

NOTES

NOTES

Example of using a basic Fill

As a quick start introduction to creating fills and example to populate an empty range with notes followed by filling the FX1 for the series of notes with a pan variation effect. This will play a percussion segment,

CREATING A NOTE FILL

1. Press [Pattern] to select the Pattern Mode page.
2. Press [Instrument] and select a percussive sound. The '606-ClosedHat' sample has been loaded into the project instrument list and will be used for this example.
3. Press [Rec] to switch to recording mode. The step bounding box will turn red and allow editing of steps.
4. Select a range of empty steps: Hold [Shift] + [Up], [Down], [Left] or [Right]. For this example select 8 step rows on a single track. The option for selecting multiple rows and tracks is possible.
5. Ensure the notes step parameter is selected in the pattern range selected: Press [Note], which will be highlighted solid red.
6. Press [*Fill*], 4th Screen button. This will open the Fill utility pop-up window.
7. Press [*Where?*], 1st Screen button. Repeat presses will cycle through the options. Also, with the 'Where?' section highlighted, [Up], [Down] or Turning (Jog) will select options.

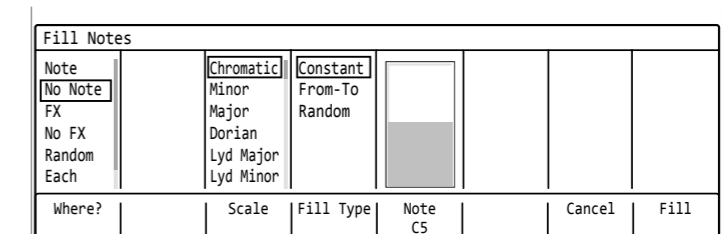

8. Select in the bounding box 'No Note'. This option will select all steps that do not have a note set. As the selected range is empty all 8 steps will be filled with this option.
9. Press [Scale] - 3rd Screen Button. Repeat presses will cycle through the options. Select 'Chromatic'. As this is a percussion instrument the scale is less important.
10. Press [Fill Type] - 4th Screen Button. Repeat presses will cycle through the options. Select 'Constant'. As this is a percussion pattern the instrument does not require scale or note ranges so constant will repeat the note.
11. Press [Note] - 5th Screen Button. Repeat presses will cycle through the options. The quickest method here is to Hold [Note] + [PAD] or Turn (Jog) to assign a note. Set to C5, the root note for the sample.
12. Press [Fill], 8th Screen button. This will activate the fill command and populate the selected range.

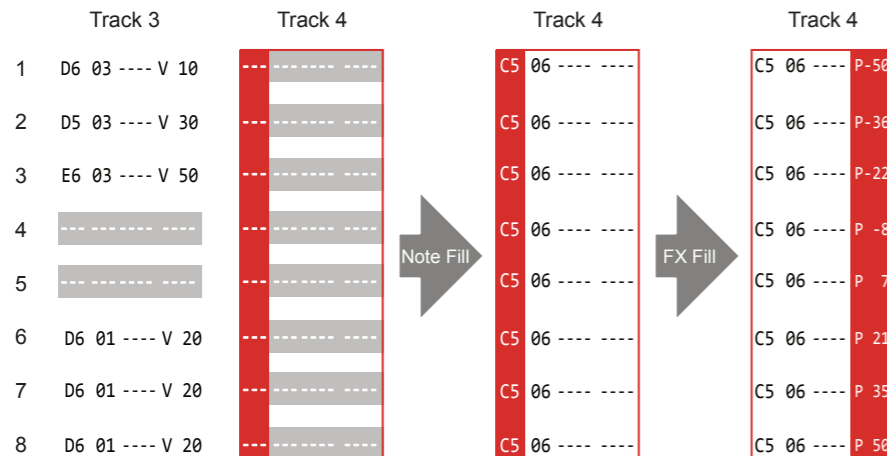

NOTES

NOTES

ADDING THE PAN VARIATION USING FILL

1. Following from the previous example; In [Pattern] with [Rec] Mode On, ensure the previous step range is still selected.
2. Press [FX2]. This selects the effect column FX2 which is highlighted solid red.
3. Press [Fill] Screen Button. This will open the Fill utility pop-up window. The display will now be different as the fill utility is now FX, not Note Fill.
4. Press [Where?] - First Screen button. Repeat presses will cycle through the options. Also, with the 'Where?' section highlighted, [Up], [Down] or Turning (Jog) will select options.
5. Select in the bounding box 'Note'. This option will select all steps that have a note set. This is effectively the range of notes recently created.
6. Press [Fx Type], 3rd Screen button. Repeat presses will cycle through the options or [Up] or [Down] or (Jog). Select 'Panning', as the effect to fill into the selected range.
7. Press [Fill Type], 4th Screen button. Repeat presses will cycle through the options. Select 'From-To' to allow a range of pan values to be filled.
8. Hold [From], 5th Screen button + [PAD] or Turn (Jog) to assign a value. Set this to -50.
9. Hold [To], 6th Screen button + [PAD] or Turn (Jog) to assign a value. Set this to 50.
10. Press [Fill], 8th Screen Button. This will activate the fill command and populate the selected range. This will create a percussive pattern which will pan left to right in the stereo image. The values are automatically assigned in equal intervals across the range.

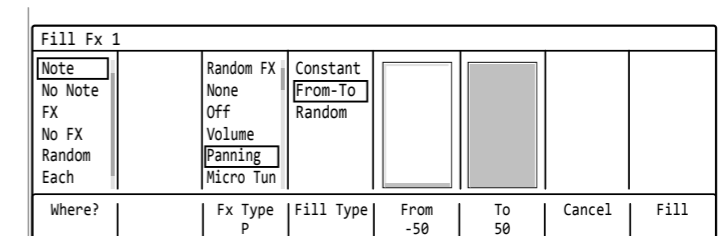

Fill Utility Generic Page Parameter - Where.

The Fill utility will present options respective to the selected step parameter. If for example an FX parameter is selected in a range, then the fill utility will represent FX Fills. Some elements like 'Where?' and 'Fill Type' are generic.

Where?

Fill Notes						
No Note		Chromatic	Constant			
FX		Minor	From-To			
No FX		Major	Random			
Random		Dorian				
Each		Lyd Major				
Euclidean		Lyd Minor				
Where?	Step 1	Scale	Fill Type	Note C2	Cancel	Fill

The 'Where?' option determines where in the selected step range the fill steps and defined parameters will be placed. This will fill new steps into the steps in the range which are empty, already filled or both depending on the selected option.

Option	Sub - Option	Description
Note	-	Will populate only steps in the selected range where a note already exists, overwriting the original value.
No Note	-	Will populate only steps in the selected range where no note exists, ie blank note steps
FX	-	Will populate only steps in the selected range where an FX parameter already exists, overwriting the original value.
No FX	-	Will populate only steps in the selected range where no FX parameter exists, ie blank FX steps
Random	-	Will populate steps in the selected range randomly for both existing and blank steps. Density is a related option.
Random	Density	Density parameter controls, in percentage how much of the range is filled when the 'Random' option is selected.
Each	-	Populates steps in the range with a defined step interval which ranges from 1-32. Step is a related option.
Each	Step	Step parameter controls the intervals of evenly distributed step fills when the 'Each' option is selected
Euclidean	-	Generates rhythmic patterns within the range based on the population of 1-32 events. Event is a related option.
Euclidean	Event	Events determine how the steps and intervals are generated with respect to the selected step length.

NOTES

NOTES

Euclidean Patterns

Euclidean patterns are a more creative fill function. While the other options perform a population based on structure, Euclidean option aims to be more creative in generating musical sequences. Euclidean patterns are generated based on a mathematical model where the steps and intervals determine a pattern melody. Tracker uses 'events' and the step length to calculate the steps and intervals.

Consider the following formula as rough guide for Euclidean filled patterns. Steps will be 'rounded' to the nearest step location to spread as 'evenly' as possible within the event and length constraints.

Step Length / Euclidean Event Setting

Examples:

8 Steps in the Length, Event = 4.

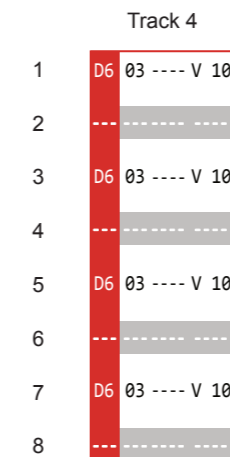

8 Steps in the Length, Event = 5.

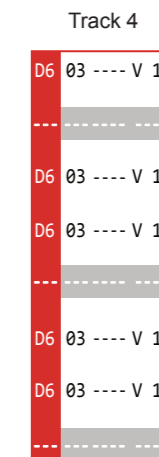

8 Steps in the Length, Event = 7.

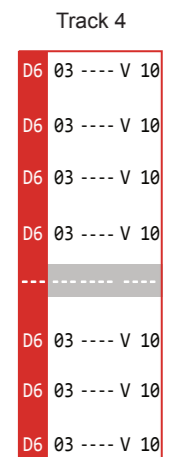

4 Steps in the Length, Event = 3.

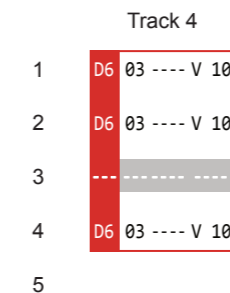

5 Steps in the Length, Event = 2.

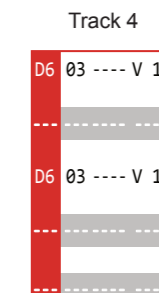

3 Steps in the Length, Event = 2.

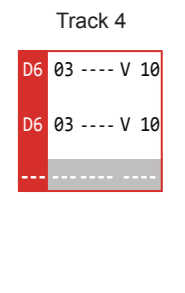

Fill Utility Generic Page Parameter - Fill Type.

The 'Fill Type' option is another generic parameter in the Fill Utility and concentrates on range of fill values.

Fill Type

The 'Fill Type' option operates on the parameter value and determines how the fill parameter is applied into the selected step range. This will fill the parameter as an individual repeated element, be based on a range of values or randomise the step parameters.

Option	Sub - Option	Description
Constant	-	Populates the steps applied with fixed singular parameter value as stated with Note, Instrument or FX
Constant	Note, Instrument or FX	Sets the parameter value to be applied when filling steps. This will differ depending on Note, Instrument, FX
From-To		Populates the steps applied with multiple parameter values distributed across the defined range
From-To	From	Starting point for the parameter value range which will be used to fill the steps range.
From-To	To	End point for the parameter value range which will be used to fill the steps range.
Random		Populates the steps applied with multiple random parameter values distributed across the defined range
Random	From	Starting point for the parameter value range which will be used to randomly fill the steps range.
Random	To	End point for the parameter value range which will be used to randomly fill the steps range.

Fill Notes

Filling a selected range will also be based on the parameter selected. When the step range is selected the fill parameter options will reflect the parameter selected in the range.

Fill Notes

When Notes are selected the note scale will be available for the notes that will be filled into the range. The notes will be constant, random or between the from-to range.

Scale	Scale Label	Scale	Scale Label
Chromatic	Chromatic	Ukranian	Ukranian
Minor	Minor	Marva	Marva
Major	Major	Todi	Todi
Dorian	Dorian	Whole Tone	Wholetone
Lydian Major	Lyd Maj	Diminished	Dim
Lydian Minor	Lyd Min	Super Locrian	SLocrian
Locrian	Random	Hirajoshi	Hirajoshi
Phrygian	Phrygian	In Sen	In Sen
Phrygian Dominant	PhrygDom	Yo	Yo
Mixolydian	Mixlydian	Iwato	Iwato
Melodic Minor	Melo Min	Whole Half	WholeHalf
Harmonic Minor	Harm Min	Kumoi	Kumoi
BeBop Major	BeBopMaj	Overtone	Overtone
BeBop Dorian	BeBopDor	Double Harmonic	DoubleHarm
BeBop Mixolydian	BeBopMix	Indian	Indian
Blues Minor	Blues Min	Gypsy Minor	GypsyMin
Blues Major	Blues Maj	Neapolitan Major	NeapoMaj
Pentatonic Minor	Penta Min	Neapolitan Minor	NeapoMin
Pentatonic Major	Penta Maj	Enigmatic	<i>Not used for Fill</i>
Hungarian Minor	Hung Min		

Fill Instruments

When the instrument parameter is selected in the range, the fill will apply instrument fills. This is based on the project instrument pool.

Fill Instruments

Track 4

Fill Instruments						
Note		Constant	606 Kick			
No Note		From-To	606 K2			
FX		Random	Sample1			
No FX			InstX			
Random			InstY			
Each			InstZ			
Where?		Fill Type	Instrument		Cancel	Fill
			2			

When Instruments are selected the instrument pool for the project is presented. It is also possible with From-To or Random Fill Type to populate the steps with multiple instruments across a variety of steps.

Fill FX

When either of the FX parameters is selected in the range, the fill will apply FX fills. This is based on the effects FX list available within Tracker.

Fill Instruments

Track 4

Fill Fx 1						
Note		Random FX	Constant			
No Note		None	From-To			
FX		Off	Random			
No FX		Volume				
Random		Panning				
Each		Micro Tun				
Where?	Fx Type	Fill Type	From	To	Cancel	Fill
	P		-50	50		

When any of the two FX are selected the Tracker effect list is presented as 'Fx Type'. The selected effect character is shown under the name. It is also possible with From-To or Random 'Fill Type' to populate the range of steps with variations for the FX value setting.

NOTES

NOTES

5.7 Live Recording Steps

Live recording offers an alternative to manual recording when programming steps into a sequence. Each method fits to certain applications better than others. Manual step recording is useful building complex and precise melodies and arrangements. Live recording is good for repetitive and natural sequences. As always this will be based on individual taste and a fit to personal workflow preferences.

Live recording allows steps to be placed in real time while the sequencer loops enabling multiple cycles of steps to be recorded.

Live Recording Considerations:-

- It is often useful to set the metronome to on, found in the Config menu when live recording to aid the timing.
- Recordings can be edited afterwards using the editing tools and process as described with manual recording. Live recording is useful to grab quick sequences and edit for accuracy afterwards.
- Recording uses the grid pads just like a drum machine or a keyboard. The pads are not velocity sensitive so will record at fixed velocity. Use an external MIDI Keyboard for recording velocity.
- The habit of arming tracks is helpful. Armed tracks can be recorded. By default tracks will shift recording to the next right track step if the active step being recorded coincides with an existing step.
- Quantization settings are in the config menu under 'Recording options'. Micro moves, slightly nudge and offset the note timing and can also be live recorded.

Tip: The technique of reducing the project tempo for live recording can be helpful in capturing more precise musical and rhythmic patterns at a slower rate. Turn the tempo back to it's normal setting once the pattern has been recorded.

PREPARING FOR LIVE RECORDING

A number of settings are available when recording live. These are optional depending on circumstances.

- Set the Metronome On/Off: Config > Metronome: State = On.
- Set the Pre roll count in On/Off: Config > Metronome: Pre roll = On.
- Set Quantize: Config > General > Recording Options
- Arm or Disarm a track to allow recording:-
Hold [Shift] + [Rec] + Screen Button to toggle arm/disarm per track. Note that only arming the target track to record to will avoid steps being recorded to adjacent tracks when steps are occupied.
- Ensure the Note parameter is highlighted which will allow recording steps. If the Instrument or FX is highlighted by default, then these will be recorded.
- Hold [Instrument] + Turn (Jog) or Press [PAD] to set a default instrument to record.

SETTING QUANTIZE RECORDING OPTIONS

1. Press [Config] to select the settings options.
2. In the left window, Turn (Jog) to highlight 'General'.
3. Press [Right] to select the 'General' sub menu.
4. In the central window sub menu, scroll using (Jog) to select 'Recording Options'. These will determine the quantize for recording:-
 - Only Notes: Quantize notes only.
 - Microtiming: Will record a nudge or offset as it is played by recording as a 'Micro-move' FX value in the step. Delete these FX to revert to quantized values.
 - Velocity: Record velocity at a fixed value with pads. Use an external MIDI Keyboard to record in real time velocity values. Velocity is recorded as an FX value.
 - Microtiming + Velocity. Record into both FX the fixed velocity and real time microtiming values.

NOTES

REAL TIME LIVE RECORDING A PATTERN

1. Press [Pattern] to select the Pattern Mode page.
2. Hold [Instrument] + Turn (Jog) or Press [PAD] to select the instrument to record. The Note will be live recorded with pads.
3. Press [Rec] + [Play] to start live recording mode. The sequencer will start immediately or after a count in of 4 if 'Pre roll' is set on.
4. Press [PAD] in real time to record. The pad note will be recorded along with the default instrument selected. Notes are recorded along with a 'Note Off' value.
5. To change optionally to instrument or FX recording, Press [Instrument] or [FX] during live recording. A 'Note Off' value is not recorded with these options.
6. Steps will be recorded into the current track. Notes will not be overdubbed. Any recording that coincides with an existing note will by default be recorded into the step row on the next track right. This behaviour is dependant on arming of tracks.
7. Press [Rec] to leave recording mode but to continue playing.
8. Press [Play] to stop playback.

NOTES

5.8 Note Steps

One of the four components of a step event is a Note. This may be a musically scaled note or a note assigned to a sample or slice. Essentially note controls a single note pitch in the step event for the instrument.

Note Summary

Note parameter has a dedicated button when working in the pattern.

Note is the first parameter in the step event and is highlighted when selected

Pads are used to populate a note value to the step event. Also it is possible to use (Jog) & [Up], [Down], [Left], [Right]. Press [Shift] + (Jog) to adjust existing note step in octaves.

C6	C#6	D6	D#6	E6	F6	F#6	G6	G#6	A6	A#6	B6
C5	C#5	D5	D#5	E5	F5	F#5	G5	G#5	A5	A#5	B5
C4	C#4	D4	D#4	E4	F4	F#4	G4	G#4	A4	A#4	B4
C3	C#3	D3	D#3	E3	F3	F#3	G3	G#3	A3	A#3	B3

Chromatic Scale shown - default

Lowest Note

The notes value are mapped across the pads. Starting at C3 bottom left, by default and pad top right, ends at B6. This therefore covers four octaves.

The Notes layout can be changed in the 'Config' Menu. Three key parameters are important when changing note layout for pads:-

Pads Layout - Default = 12
Found in Config > Project Settings
In semitones for pad directly above root

Pads root note - Default = C3
Found in Config > Project Settings

Pads Scale - Default = Chromatic
Found in Config > Pads Scale
A full list of available scales is shown in the description for the fill utility.

NOTES

NOTES

DETAILED APPLICATION OF A NOTE VALUE TO A STEP EVENT

1. Press [Pattern] to select the pattern mode page.
2. Select a blank or existing step event.
3. Press [Note] to ensure the note parameter is selected in the step event. This is a short press - do not hold [Note] otherwise this will only temporarily select the parameter while being held.
4. Select recording mode, Press [Rec]. The steps selected will appear red as opposed to green when in normal playback mode.
5. Set a Note by either:-
 - Press [PAD] to select the note based on the note assigned to the pad selected. Will not display note screen. Pressing [PAD] will also iterate steps based on 'Step Jump' setting. *Fastest Method.*
 - Hold [Note] + [PAD]. The pad selected will refer to the note applied. The pads are laid out based on settings in the config settings but default is Chromatic, C3 - B6. *Fast & Most Accurate Method.*
 - Hold [Note] + Press [Up] or [Down], [Left] or [Right]. Navigation and selection is shown on the note screen. Release [Note] to select. *Accurate, But Slower Method*
 - Hold [Note] + Turn (Jog). Adds a note value to the step. Navigation is displayed on the pad note screen. *Accurate But Slowest Method.*
 - Hold [Note] alone, until pad notes are displayed and then release [Note] to apply C0 to the step event. Applied to empty steps only. Note can be edited later if required. *Quick but Inaccurate Method.*
6. The note will be added, displayed with teal coloured text. Notes are always added along with the currently selected instrument. Notes can be edited once created with (Jog) or [Shift] + (Jog) to change note by full octaves.

Pads can be used to play live samples both using instruments and when controlling external gear via MIDI from the pattern page. When in REC mode - red state, the entire step is played including FX and respective BPM. When in the Green, none recording mode will only play the note and instrument.

Polyphony & Chords

Each track in Tracker can handle one voice which can play multiple notes, but not simultaneously. This can be a limitation when creating chords which would need a track per note. A triad would need 3 tracks to play the chord.

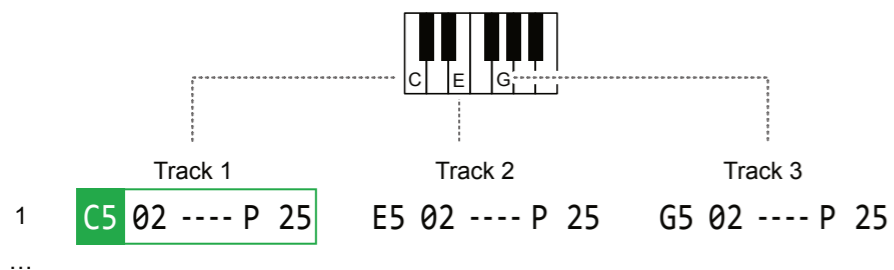

As a work around the tracks can be rendered to a new audio sample and reduce the track usage down. This re-sampling method can also be used to render into an audio file when FX slots are full.

RENDERING TRACKS TO AUDIO CHORDS

1. Press [Pattern] to select the pattern mode page and Press [Rec] to select record edit mode.
2. Hold [Shift] + [Up], [Down], [Left], [Right] to select the range to render. For example, select across all the tracks making up the chord and the pattern duration of 16 steps
3. Press [More]. The 8th Screen Button to select more pattern options.
4. Press [Render Selection], the 1st Screen Button.
5. The naming page appears. A name can be edited or press [Auto Name], 5th Screen Button to automatically apply a name.
6. When the name is entered, Press [Render & Load], 7th Screen Button. This option will not only render the audio but also automatically load the sample into the instrument list. The pattern will halt playback if playing.
7. When the file has been 'exported', the instrument list will open ready to preview or select the sample exported.
8. Press [Pattern], to return to the pattern page. Now replace the instrument on a track with the rendered chord sample. Ensure the note is set to the same default for the sample playback, example C5.
9. Remove the other track samples to free them up.

NOTES

NOTES

Special Note Commands

Three special note commands can be applied instead of the actual note value. These are not used for applying a note sound, but are used for controlling how a note ends. These include CUT - Immediately silences the audio, FAD - Fades out audio gradually and OFF - Triggers Note Off for the envelope and starts the release phase.

To access these options, while 'Note' is selected, Turn (Jog) fully counter clockwise to access the 3 commands.

FAD - Fade.
Will gradually reduce the audio sound and fade it out. Also will turn MIDI Notes off.

FAD 02 ---- v 45

CUT - Cut.
Will immediately stop the audio sound. Also will turn MIDI Notes off.

CUT 02 ---- v 45

OFF - Off.
Will act as 'Note-Off' and trigger the release phase of the envelope to reduce the sound.

OFF 02 ---- v 45

5.9 Instrument Step Parameters

Each step event has an instrument which is based on a sample, either raw or edited or formed into a granular or wavetable instrument. Any instrument added to the 48 instrument pool is available to be added to a step.

Instrument Summary

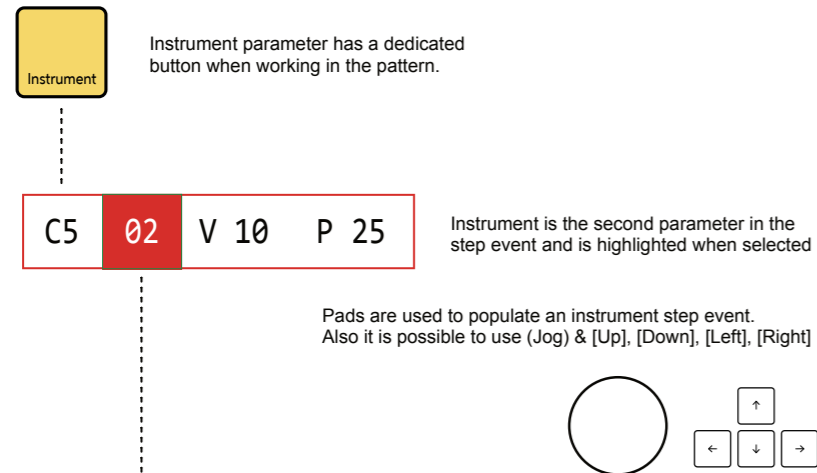

1	2	3	4	5	6	7	8	9	10	11	12
13	14	15	16	17	18	19	20	21	22	23	24
25	26	27	28	29	30	31	32	33	34	35	36
37	38	39	40	41	42	43	44	45	46	47	48

Instruments in the pool are mapped across the pads. Starting at 1 top left and pad bottom right, ends at 48. This therefore covers the entire 48 instruments slots.

While holding [Instrument], the pop-up window will display the available instrument list where the selection can be made to load to the step event.

Pattern 1				P1.008				Instruments	
1	C5 40	----	P-25	C5 40	----	H-25	C5 40	1. Strange Sample Number 1	
2	C5 40	----	P-25	C5 02	----	P-20	C4 12	2. Deep Kick	
3	----	----	----	----	----	----	----	3. Transient Kick	
4	----	----	----	----	----	----	----	4. Snare One	
5	----	----	----	----	----	----	----	5. Closed Hat 1	
6	----	----	----	----	----	----	----	6. Deep Pad	
7	----	----	----	----	----	----	----	7. Grainy Pluck	
8	----	----	----	----	----	----	----	8. Grrrrr	
9	----	----	----	----	----	----	----	9. DawgGawn	
10	----	----	----	----	----	----	----	10.	
11	----	----	----	----	----	----	----	11.	
12	----	----	----	----	----	----	----	12.	
13	----	----	----	----	----	----	----	13.	
14	----	----	----	----	----	----	----	14.	
15	----	----	----	----	----	----	----		

NOTES

NOTES

DETAILED APPLICATION OF AN INSTRUMENT TO A STEP

1. Press [Pattern] to select the pattern mode page.
2. Select a blank or existing step event.
3. Press [Instrument] to ensure the instrument parameter is selected in the step event. This is a short press - do not hold [Instrument] otherwise this will only temporarily select the parameter while being held.
4. Select recording mode, Press [Rec]. The steps selected will appear red as opposed to green when in normal playback mode.
5. Assign an Instrument by either:-
 - Press [PAD] to select the instrument based on the number for the pad selected. Pressing [PAD] will also iterate steps based on 'Step Jump' setting. *Fastest Method.*
 - Hold [Instrument] + [PAD]. The pad selected will refer to the instrument applied. The pads are laid out 1-48 representing the instrument pool slots. *Fast & Most Accurate Method.*
 - Hold [Instrument] + Turn (Jog). Adds a note value to the step. Navigation is displayed on the pad note screen. *Accurate and Quick Method.*
 - Hold [Instrument] + Press [Up] or [Down] to highlight slots, [Left] or [Right] to scroll by page of slots. Navigation and selection is shown on the pop-up screen. Release [Instrument] to select. *Accurate, But Slower Method*
 - Hold [Instrument] alone, until pad notes are displayed and then release [Instrument] to apply the selected instrument. Note can be edited later if required. *Quick but Inaccurate Method.*
5. The instrument will be added, displayed with amber coloured text. Instruments are always added with a note.

5.10 FX Step Parameters

Each step event has two FX slots which can be populated from a library of effects. Each FX has two parts, firstly the effect type, represented by a single character and secondly it's value.

FX Summary

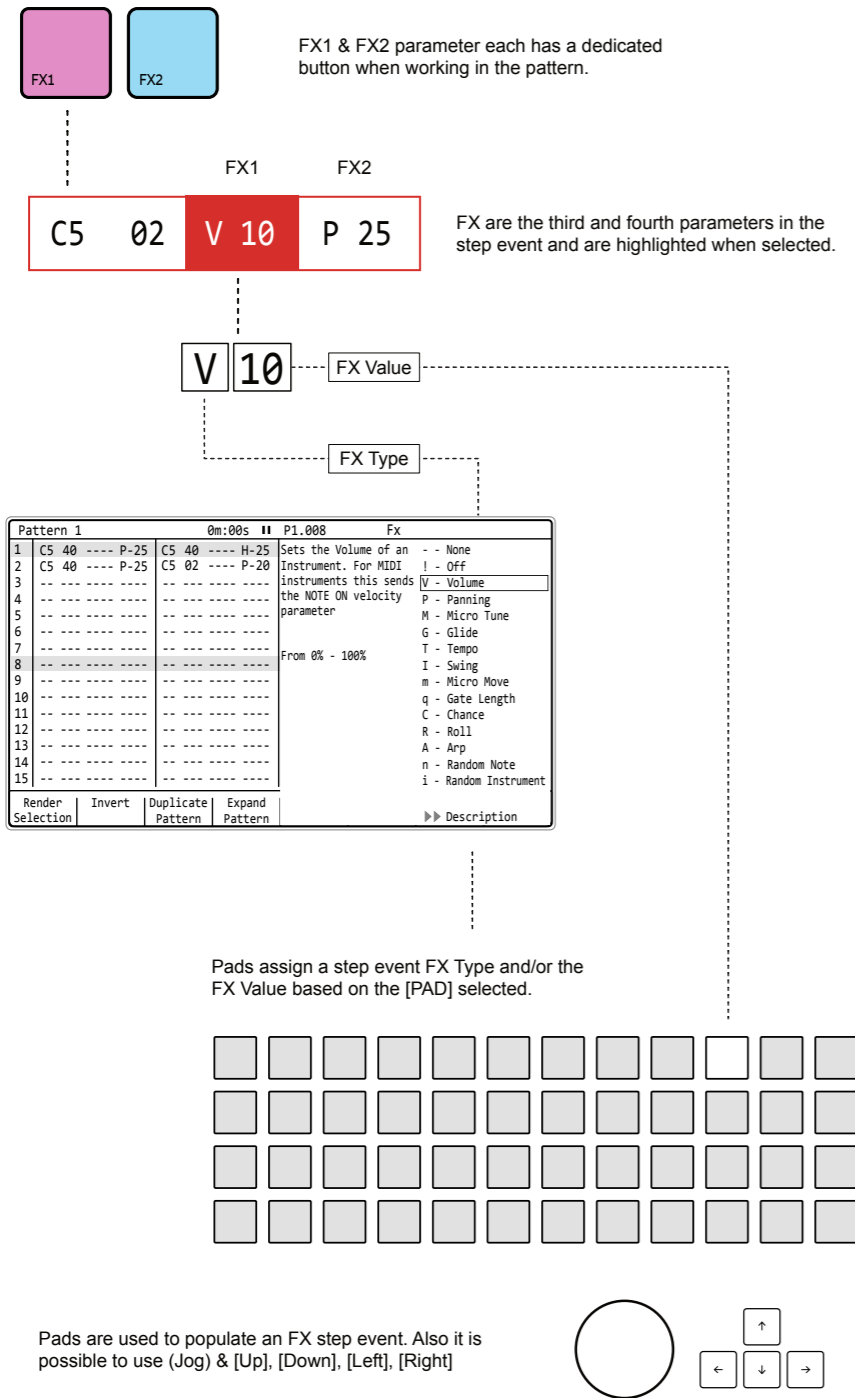

NOTES

NOTES

DETAILED APPLICATION OF AN EFFECT TO AN EMPTY STEP

1. Press [Pattern] to select the pattern mode page.
2. Select a blank or existing step event.
3. Press [FX1] or [FX2] to ensure the FX parameter is selected in the step event. This is a short press - do not hold [Instrument] otherwise this will only temporarily select the parameter while being held.
4. Select recording mode, Press [Rec]. The steps selected will appear red as opposed to green when in normal playback mode.
5. To assign FX either:-
 - Press [PAD]
 - If the step is empty it will apply both the chosen FX and also it's value which is based on the pad selected.
 - If the step is occupied, the existing FX type is retained but a value represented by the pad selected will be applied.
 - Hold [FX1] or [FX2] + [PAD]. The pad selected will refer to the FX type applied with a default value. When [FX1] or [FX2] is released the effect is applied.
 - Hold [FX1] or [FX2] + Turn (Jog). The FX type is selected with a default value. When [FX1] or [FX2] is released the effect is applied.
 - Hold [FX1] or [FX2] + Press [Up] or [Down]. The FX type is selected with a default value. When [FX1] or [FX2] is released the effect is applied. Using [Left] and [Right] will navigate in large steps.
 - Hold [FX1] or [FX2] alone. The current FX type is selected with a default value. When [FX1] or [FX2] is released the effect is applied
6. The FX1 will be displayed with the colour magenta and FX2 will be displayed with light blue coloured text.
7. Turning (Jog) on the highlighted FX slot will now adjust its value. This may also automatically preview the effect applied sound.

In the Effect window, press the 7th and 8th screen button to toggle the description of the highlighted effect on or off. This is an aid to using the FX.

FX Types.

The two FX slots can be populated from a library of FX effects. Each FX has an effect type plus the associated value.

FX Type	Description
-	None. Empty FX1 or FX1 effect. No effect applied.
!	Off. Will toggle off the effect used on the prior effect step.
V	Volume or Velocity (NOTE OFF) for MIDI.
P	Positions the step sound left / right in the stereo plane.
M	Micro Tune. Fine pitch tuning of note and MIDI Out.
G	Glide time from previous to current note - based on the note pitch.
T	Tempo change. Changes the pattern tempo.
l	Swing. Applies a swing from any step track for the entire pattern.
m	Micro move nudges forward by a small amount the step position.
q	Gate length. Adjusts the step note gate length.
C	Chance is the probability of a note playing.
R	Roll, beat repeats the note also with options for volume or pitch inc/dec.
A	Arpeggiator, for creating pitch based melodies. (Also needs MIDI Chord)
n	Random note. Sets a range of notes for random playback.
i	Random instrument. Sets a range of instruments for random playback.
f	Random FX. Sets a random FX to the step from a selected range.
v	Random Volume. Sets a random velocity variation on each cycle
r	Reverses sample playback. Played end to start.
p	Sets the playback position for a sample start, wavetable or granular position
S	Plays the selected slice for the step - sliced samples
g	Volume LFO Rate
h	Panning LFO Rate
j	Filter LFO Rate
k	Position LFO Rate
l	Finetune LFO Rate

NOTES

NOTES

FX Type	Description
D	Overdrive amount for the step
L	Low Pass Filter Cutoff. Frequency represented by 0-100%
B	Low Pass Filter Cutoff. Frequency represented by 0-100%
H	Low Pass Filter Cutoff. Frequency represented by 0-100%
s	Delay. Amount of send effect 0-100%
t	Reverb. Amount of send effect 0-100%
E	Bit depth. 4 Bits to 16 Bits.
U	Tuning. -24 semitones to +24 Semitones. 4 Octave range.
F	Slide up amount. Range is 0-255 with 1/16 th semitone increments.
J	Slide down amount. Range is 0-255 with 1/16 th semitone increments.
a	MIDI Out (CC, PC, Chan & Poly Aftertouch). Needs a channel & Instrument
b	MIDI Out (CC, PC, Chan & Poly Aftertouch). Needs a channel & Instrument
c	MIDI Out (CC, PC, Chan & Poly Aftertouch). Needs a channel & Instrument
d	MIDI Out (CC, PC, Chan & Poly Aftertouch). Needs a channel & Instrument
e	MIDI Out (CC, PC, Chan & Poly Aftertouch). Needs a channel & Instrument
f	MIDI Out (CC, PC, Chan & Poly Aftertouch). Needs a channel & Instrument
0	MIDI Chord, note output. (Used also with Arp).

6

Instruments

In the language of Tracker, an instrument is the part of a step that generates sound and is essentially based on an audio sample. Instruments are loaded into the instrument pool to be accessible in a project (explained in the project section). At its core an instrument has a sample or part of a sample along with a set of defined settings. The sample parameters set the configuration of the sample itself and also the integration within the Tracker instrument feature set. A sample can be sliced for example to be used as beats in a drum kit. It can form the central audio source for the wavetable and granular engines. These operate like synthesizers. It can also simply be a pure stand alone sample. Building of instruments and their application in Tracker is an essential foundation for sound design. MIDI instruments also exist and the application of these is covered in the MIDI section. There are a variety of things that can be done to create

an instrument. Working with instruments clearly has a cross over between the practical, process orientated tasks and the creative, inspirational parts. Both are equally important and often it is worth dedicating time purely to sound design and instrument creation. Building a library of say, percussion, drums, bass, leads, or pads and textures, and so forth is good practice. This can make the track design and full song production workflow smooth and simple, helping to switch the focus on the assembly and creation of patterns. Instruments are stored as '.pti' files and can be used across projects and can be distributed and shared with others. Tracker provides an all in one solution for music making and having a collection of instruments readily available makes this music making process faster and more effective.

6.1 Instrument Overview

An audio instrument is the primary sound source in Tracker and is based on an audio sample. The instrument can be a raw sample or configured into a more elaborate instrument such as wavetable. The instrument parameters will configure settings. The sound can be affected by effects and modulation but essentially an instrument has a sample at its core and is triggered by the step on which it is applied. MIDI Instruments are also available which are covered in the MIDI section.

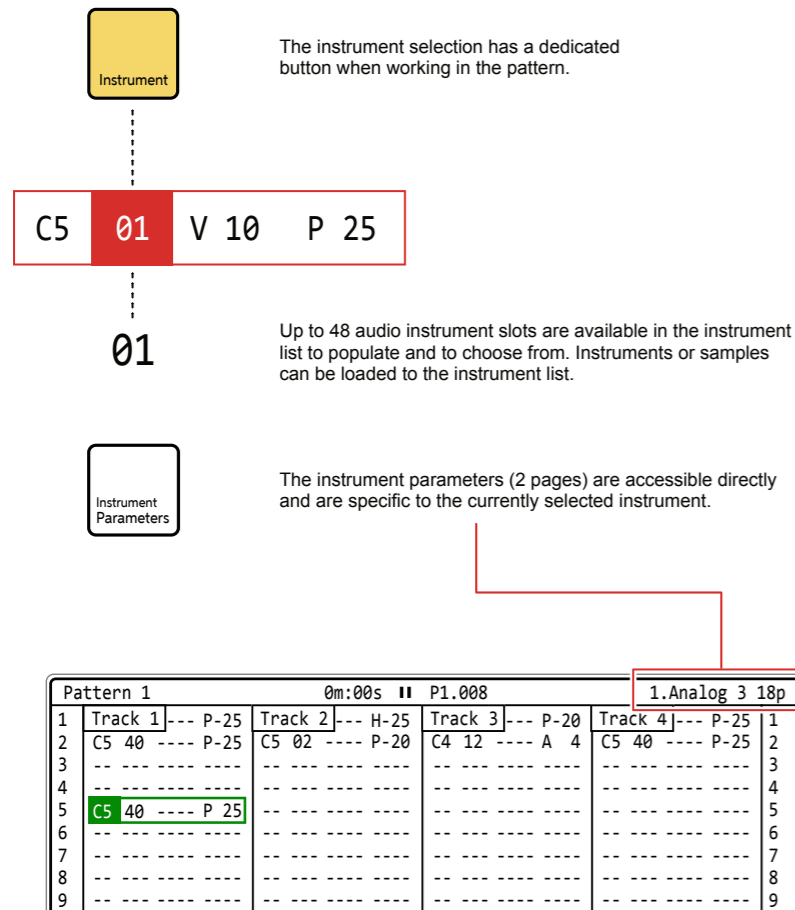

.pti Instruments can be created from samples, edited, sliced and saved as '.pti' files which can then be used in other projects or shared with others.

NOTES

NOTES

6.2 Instrument Parameter Pages

A series of instrument parameters are accessible for controlling, shaping and modulating the sound. The two pages are accessible directly from toggling the [Instrument Parameter] button. Page 1 is general parameters while Page 2 focusses on parameter automation. Remember, pressing [Delete/Backspace] on a selected parameter will reset it to its default state.

Page 1 of 2: General Sample Based Parameters

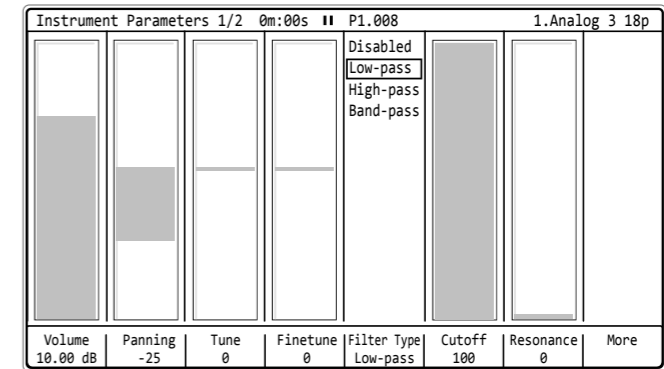

Press to select and cycle the instrument parameter pages

Page 2 of 2: Automation Parameters

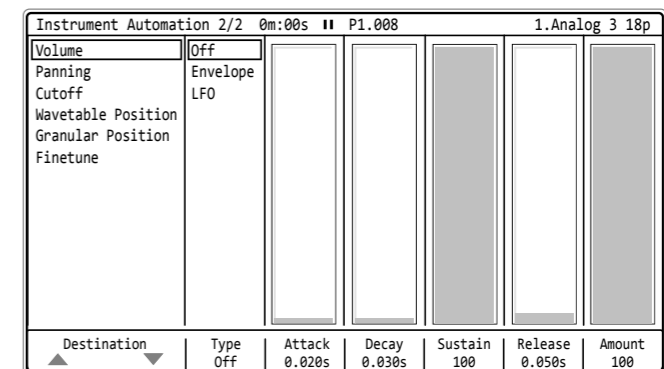

Screen buttons select the parameter options or [Right] [Left] to navigate option. Then turn (Jog) or press [Up] [Down] to adjust / select

6.3 General Instrument Parameters - Page 1

The general settings page covers sample based parameters that affect general audio functions.

Volume / Pan

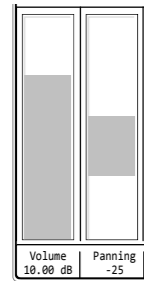

- Volume**
Adjusts the audio level of the instrument.
Range is -inf dB to 24.00 dB
- Panning**
Adjusts the audio position left to right balance in the stereo field.
Range is -50L (fully left) to +50R (fully right)

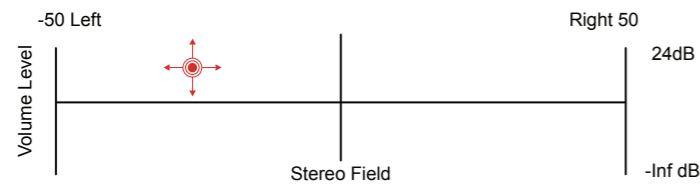

Tuning

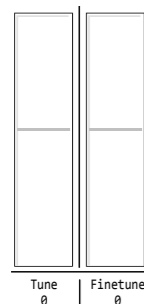

- Tune**
Adjusts the audio pitch tuning of the sample.
Range is -24 Semitones to +24 Semitones
- Finetune**
Adjusts the sample audio pitch fine tuning.
Range is -100 Cents to +100 Cents

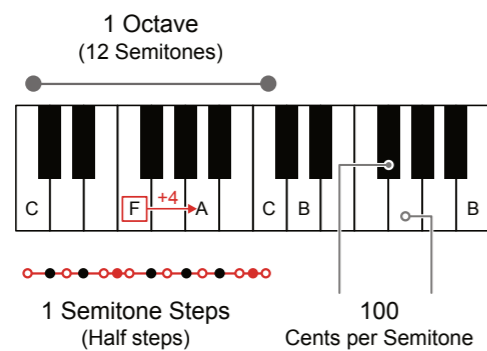

NOTES

NOTES

Filter

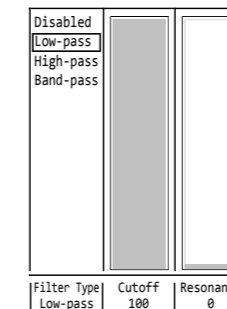

- Filter Type ①**
Selects the type of filter to apply.
Options; Disabled, Low-pass, High-pass, Band-pass
- Cutoff ②**
Filter cutoff frequency. Point of attenuation.
Range is 0% to 100%
- Resonance ③**
Boosted frequency point to create resonance.
Range is 0% to 100%

Filter Types & Functions

A filter attenuates and cuts areas of the frequency range in an audio signal.

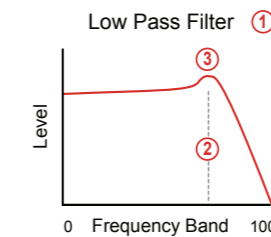

A low pass filter allows the frequencies through which are below the cutoff frequency and attenuates the audio signal frequencies above the cutoff. Resonance boosts the audio at the selected frequency.

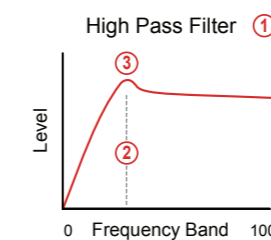

A high pass filter allows the frequencies through which are above the cutoff frequency and attenuates the audio signal frequencies below the cutoff. Resonance boosts the audio at the selected frequency.

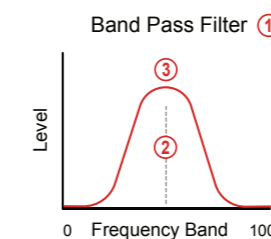

A band pass filter allows frequencies through within a band of the cutoff frequency and attenuates the rest of the audio signal frequencies. Resonance boosts the audio at the selected frequency. Band width (Q) is not adjustable in the Tracker band-pass filter.

Access to control the general parameters is simple and quick. The process described applies when accessing all instrument parameters and effects.

ADJUSTING INSTRUMENT PARAMETERS

1. Ensure the desired instrument is selected. This will be shown top right of the screen.
2. Press [Instrument Parameters] to select the parameters pages.
3. Pressing [Instrument Parameters] again will toggle between the general parameter page and the automation parameters.
4. Within the instrument page 1/2 (displayed top left), the instrument effects are accessible. Press [More], 8th Screen button to open the effects page, and press [Back] to return to the main page.
5. Press the screen button below the desired option to select. Pressing [Left] or [Right] will navigate the options. The selected parameter will show a red bounding box.
6. Within a selected option, Turn (Jog) to manually adjust the parameter value e.g. Volume.
7. Alternatively, Press [Up] or [Down] to incrementally adjust the parameter value. Holding [Up] or [Down] will continuously adjust the value.
8. With a parameter selected, Press [Delete/Backspace] to reset it's value to the default setting. For example Panning will reset to 0.
9. Parameters are presented in columns. The value is shown in the graphic of the upper main page and also the exact value is shown below the parameter name in the screen button labels.
10. To exit the instrument parameters, select another page e.g. [Pattern].

NOTES

NOTES

6.4 Instrument Effect Parameters - Page 1

The general settings page 1 also gives access to a series of instrument effect parameters. There are 2 instrument specific effects, overdrive and bit depth and also 2 send controls which use the common delay and reverb.

Page 1 of 2: General Sample Based Parameters

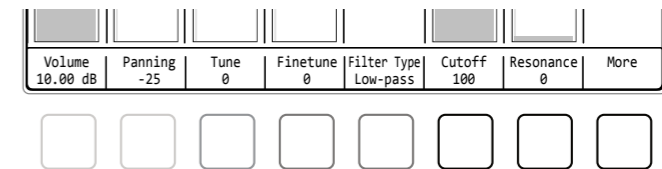

Instrument Parameter Effects

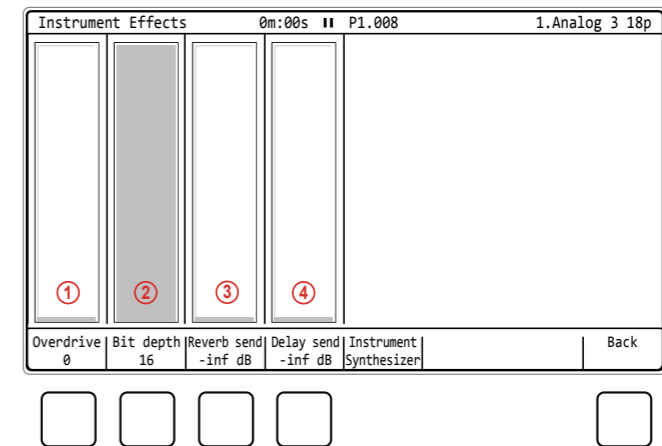

Screen buttons select the parameter options or [Right] [Left] to navigate option. Then turn (Jog) or press [Up] [Down] to adjust / select

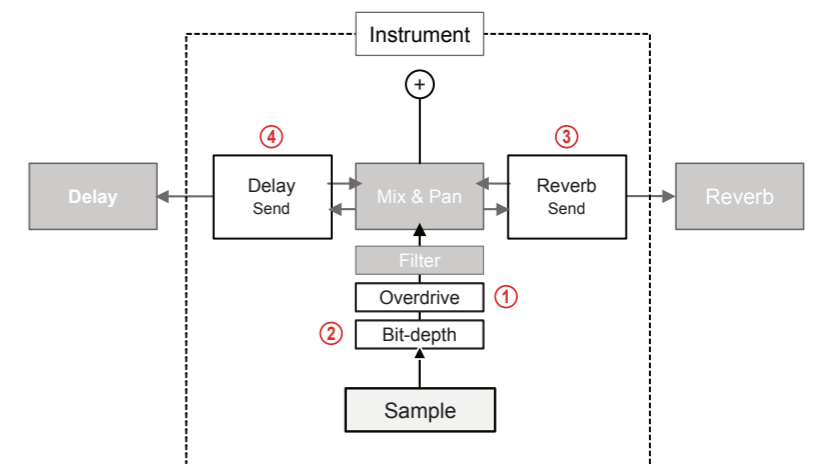

The effect settings page covers sample based parameters that affect the specific instrument. Note that the generic delay and reverb settings are in the master section of Tracker.

NOTES

Overdrive

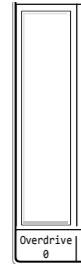

Overdrive
Overdrive introduces a gritty aggressive tone to the audio sound. Based on traditional practices of pushing the limits of an amplifier and creating distortion in the signal.
Range 0-100%

Bit Depth

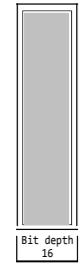

Bit Depth
Analog signal are smooth evolving shapes. Digital audio samples represent this by sampling and registering the audio information into number of bits. The higher the number the better a signal is represented. Tracker uses 16 Bit audio which is CD standard, but can be reduced to give a more LoFi sound effect.
Range 4-16

Reverb Send



Reverb Send
The reverb send is not an effect in itself but controls the amount of instrument audio that is sent to the master reverb. This is mixed to the signal and combined with other sends. Reverb adds space and represents room reflections simulating spacial depth, distance or proximity.
Range 0-100%

Delay Send

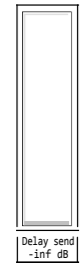

Delay Send
The delay send is not an effect in itself but controls the amount of instrument audio that is sent to the master delay. This is mixed to the signal and combined with other sends. Delay adds an echo and repetition into a sound and is a creative effect and fills space to keep interest.
Range 0-100%

NOTES

6.5 Instrument Automation Parameters - Page 2

Automation also called modulation, creates movement and interest in an instrument sound. The instrument automation settings page covers the settings which control modulation over the instrument sound audio sample. These parameters are located in the second page of the instrument parameters.

The modulator can be an LFO or an Envelope. Both shape audio over a time period for one of the several selectable destinations.

Available parameters will depend on the destination and the automation type selected.

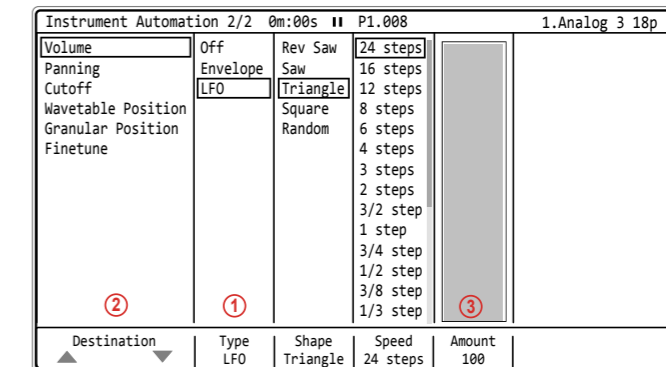

Screen buttons select the parameter options or [Right] [Left] to navigate option. Then turn (Jog) or press [Up] [Down] to adjust / select

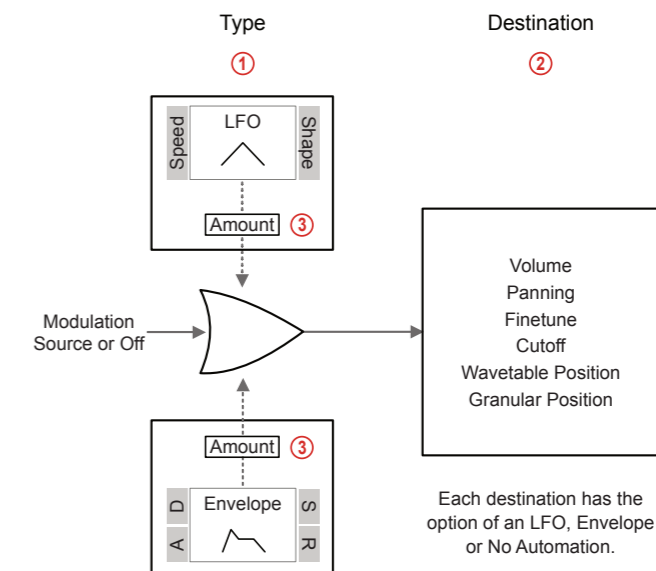

Automation can add some highly creative and interesting features to a sound. This is applied by modulating parameters in the instrument sample. This can transition from a simple, static audio sound (when type is off) to add some subtle movement to generative and evolving sound designs. Try combining and experimenting with automation.

LFO - Low Frequency Oscillator

A low frequency oscillator (LFO) operates at a lower frequency than a normal audio oscillator which is typically used as an audio generator. The purpose of an LFO is to act as a modulator for parameters of other devices, to add interest and create movement. A common use of an LFO is to add a vibrato effect to control the pitch of a sound.

LFO Shapes

Examples show 2 Cycles of the LFO shape. Speed influences cycles across pattern.

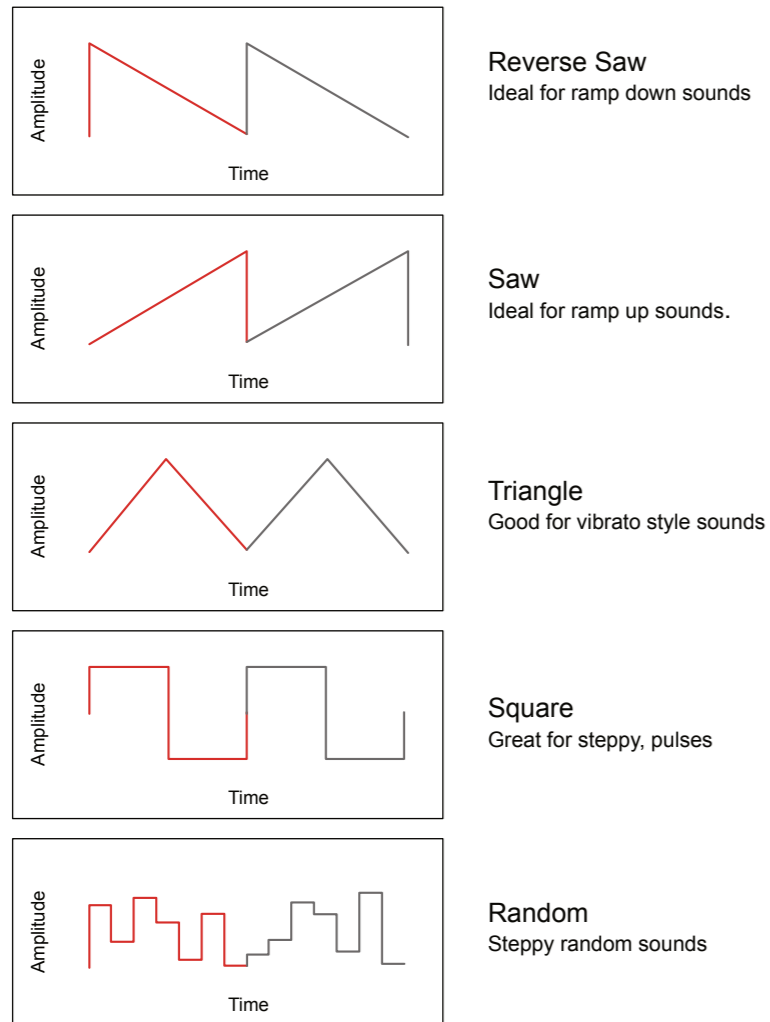

NOTES

NOTES

As well as the shape, the second key parameter is speed. LFO Speeds in tracker are hard synchronised to the project tempo and are therefore assigned based on the number or intervals of steps. Despite Tracker having a de-clicking audio algorithm, some settings may still cause audio clicks due to the LFO cycle with respect the samples zero crossing points.

LFO Speed

Speed is based on pattern step intervals.

Speed * In Steps	Speed In Steps	Speed In Steps	Speed In Steps	Speed In Steps	Speed In Steps
128	24	4	3/4	3/16	1/24
96	16	3	1/2	1/6	1/32
65	12	2	3/8	1/8	1/48
48	8	3/2	1/3	1/12	1/64
32	6	1	1/4	1/16	

* 128 to 32 Step Speed options are not available with Volume as the destination.

Speed Setting Illustrations

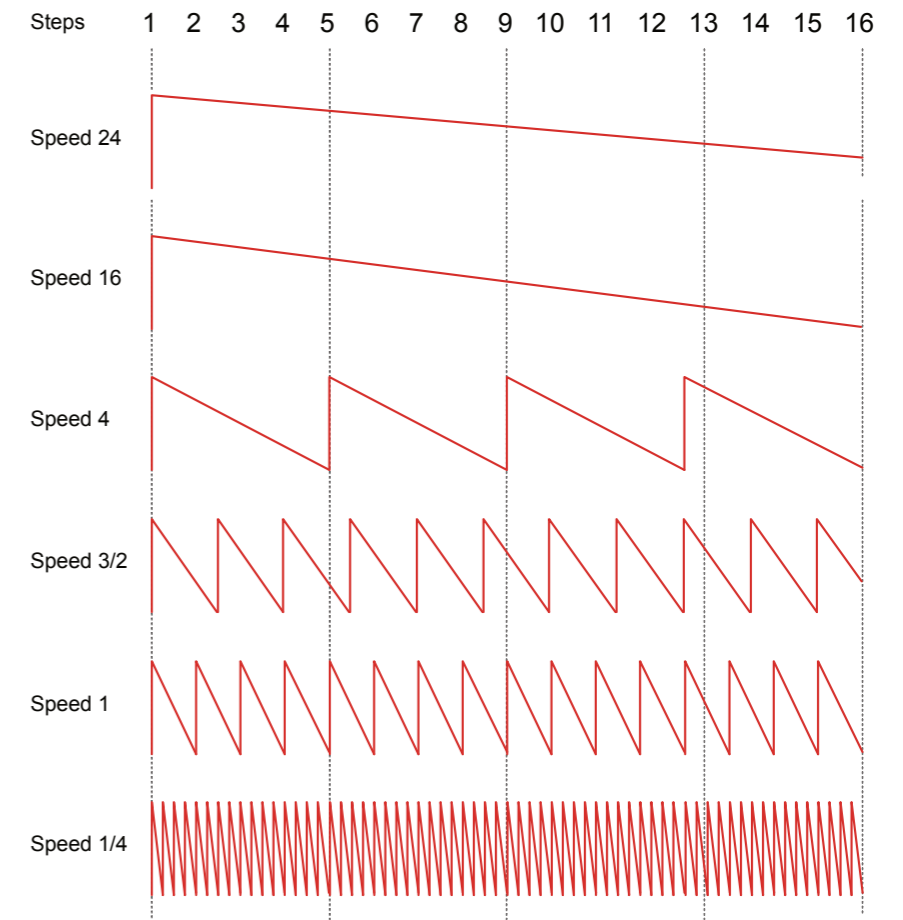

NOTES

NOTES

Example Speed & Shape Options

With respect to steps

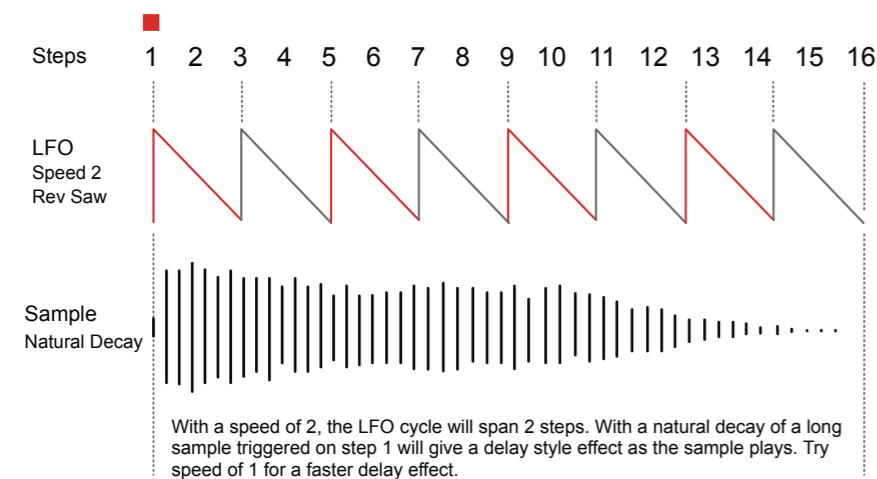
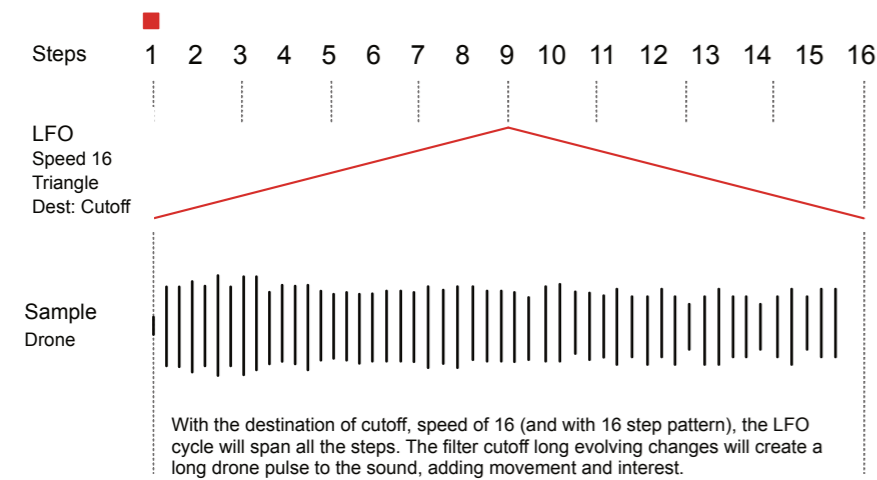
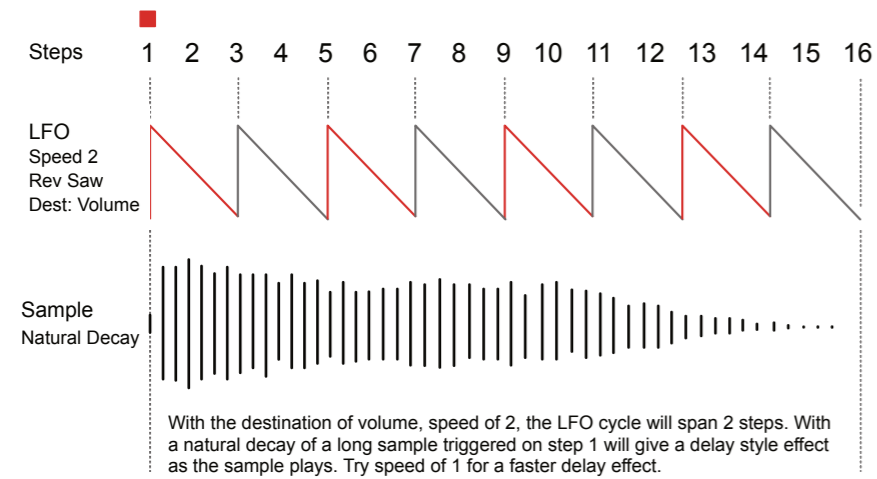

Envelope

An envelope shapes the audio over time. While an LFO will cycle, an envelope is considered more of a one-shot function and typically operates across a note length. This is normally used to shape the sound of a note and how the sound develops from note on to note off (and beyond). It can also be used as a modulation effect. Tracker uses an ADSR envelope which has 3 time setting zones, Attack, Decay and Release plus the sustain level zone.

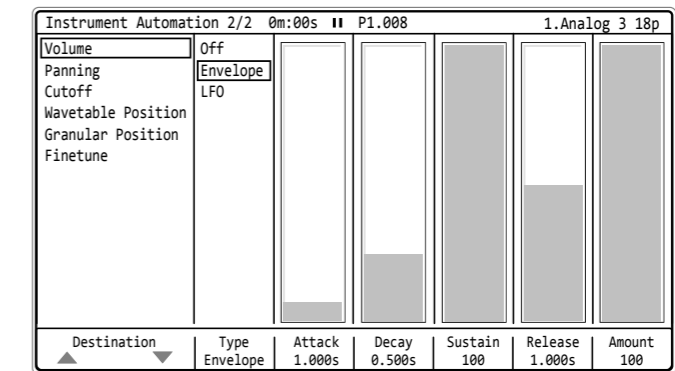

ADSR Envelope

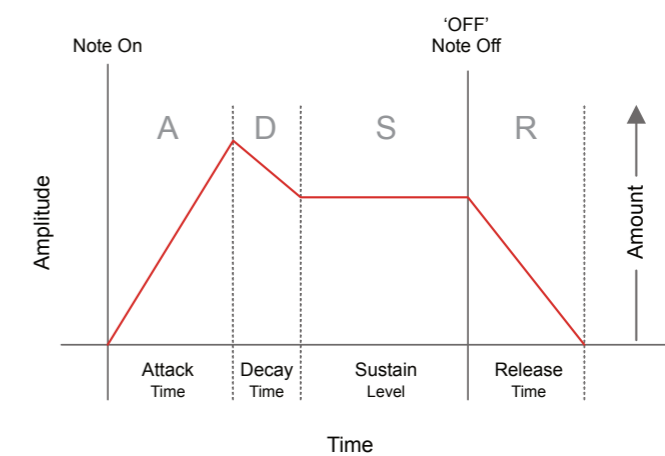

The OFF Command can be triggered on an individual step using the Note 'OFF' special command, accessible by turning (Jog) fully counter clockwise.

The envelope page covers sample based parameters that affect the shape of the instrument sound over time. The selection of each parameter may not be linear to allow for a better resolution to choose the value in the more relevant range areas. The amount will set how much of the envelope is applied 0-100%.

NOTES

Attack

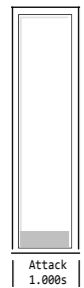

Attack Time
Attack is the initial time period of the envelope. This affects the transient of the sample. Shorter times for more percussive 'hits' and longer for more evolving ramps. Range 0-10 Seconds. 0-1 Sec has a better resolution of control.

Decay

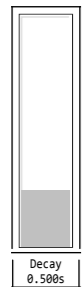

Decay Time
A decay time period which is applied after the attack phase and applying a note. The period before settling the sound level to a steady state. Range 0-10 Seconds. 0-1 Sec has a better resolution of control.

Sustain

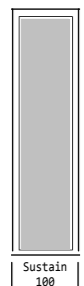

Sustain Level
This is the nominal level at which the note / sound will sustain after the initial 'note on' request. This will be the level continuously played while holding a note. Range 0-100%.

Release

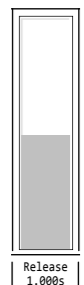

Release Time
This is the final envelope stage and is activated after the note is released - Tracker 'OFF' special note command. This is the time period where the sound dissipates from the sustain level to silence. Range 0-10 Seconds. 0-1 Sec has a better resolution of control.

NOTES

6.6 Sample Playback Overview

An instrument can be a sample, edited or raw. A raw '.wav' sample can be added to the instrument list. When a sample is edited and developed further as an instrument it can be saved as a '.pti' instrument, for example 'drumkit1.pti'. This can be used across all projects or distributed to other producers.

This section covers the basics of using .pti instruments, and not the end-to-end capturing, editing and use of audio sampling which is covered elsewhere.

How a sample is applied as an instrument is handled in the 'Sample Playback' page, accessed by the dedicated [Sample Playback] button.

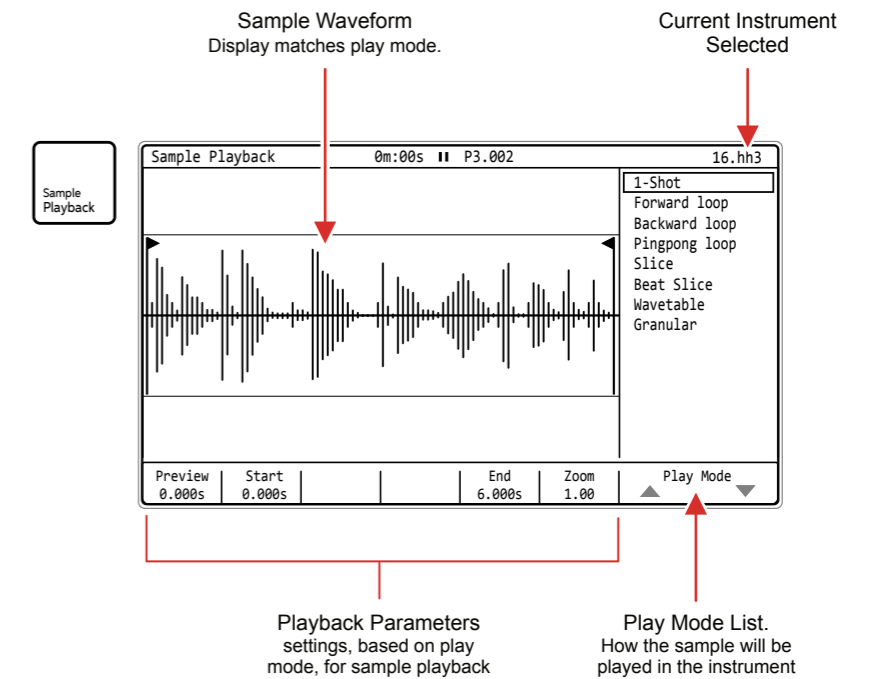

Note: Playback is not visually animated in the waveform display when playing.

Type	Play Mode	Description
Play	1-Shot	Basic sample playback. Plays start to end once.
Loop	Forward Loop	Sample playback. Plays start to end and cycles on loop.
Loop	Backward Loop	Sample playback. Plays end to start and cycles on loop.
Loop	Pingpong Loop	Sample playback. Plays start to end to start on loop.
Slice	Slice	Sample is sliced
Slice	Beat Slice	Sample is sliced
Synthesizer	Wavetable	Sample is used as the wavetable, like a synth.
Synthesizer	Granular	Sample grains are used and played, like a granular synth

6.7 1-Shot Play Mode

The most basic play mode is 1-shot which simply plays a sample through once, start to end. This is the normal operation when using samples without too audio much editing and where the general duration of the sample is to be retained.

The note value, tempo and pattern length will also affect how the sample plays. A higher note value will play the sample faster. A lower note value will play the sample slower. Triggering the instrument step will trigger the 1-shot sample which will play for its duration or until another trigger is initiated.

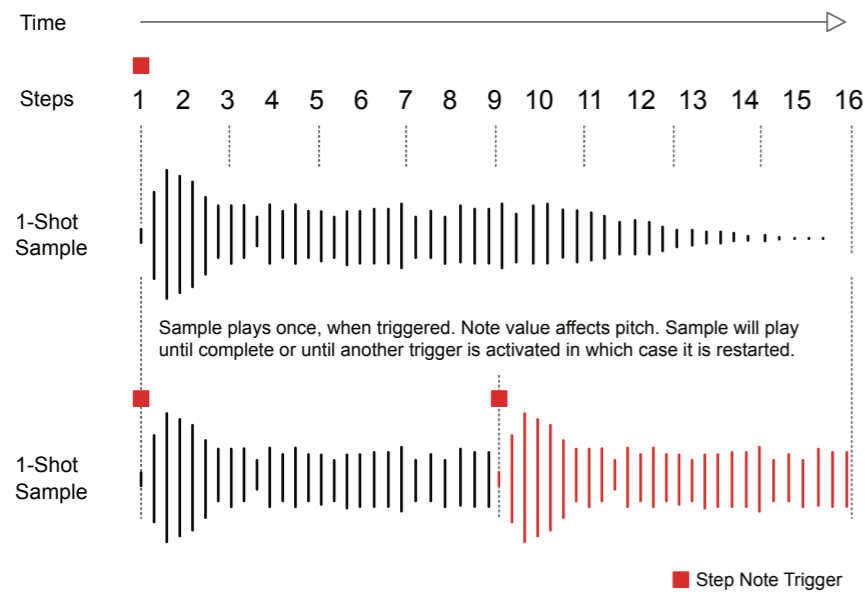

Higher note values will shorten i.e. speed up the sample while lower values will elongate i.e. slow the sample. The sample and pattern length should be considered as well as tempo to achieve desired results. Sample tempo and pitch are not automatically analysed in Tracker and therefore not normally known unless manually noted when sampling and recording the original audio.

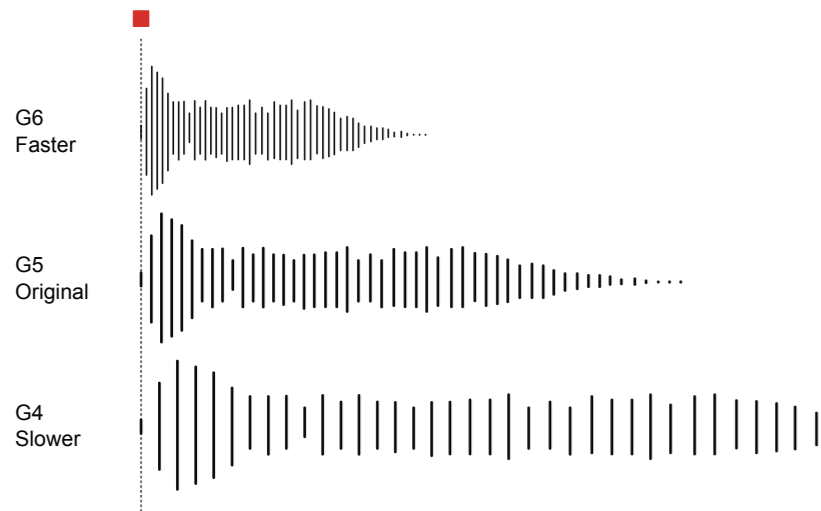

NOTES

NOTES

1-Shot Parameters

The available parameters are simple for the 1-shot option with only two editing parameters and one visual aid. Navigate and select using the Screen Buttons. Also navigation using the [Left] [Right] buttons to select the section and [Up] or [Down] or Turn (Jog) to change the value / selection.

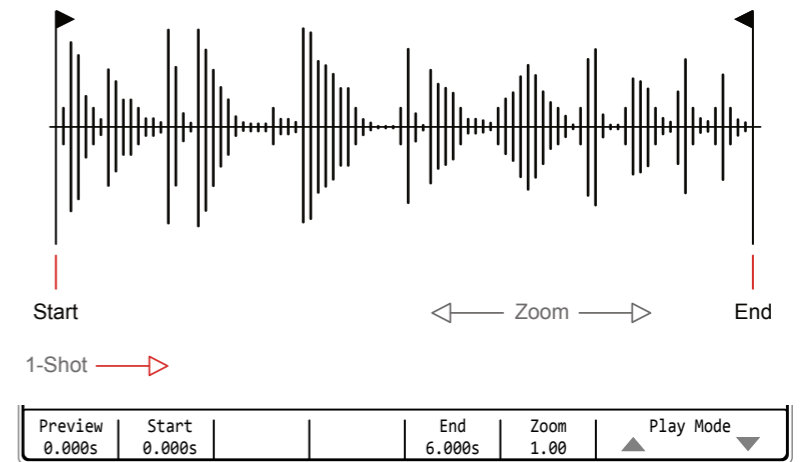

Function	Parameter	Screen Button	Range	Description
Edit	Play Mode	7th & 8th	Modes	Selects the play mode to apply. Includes 1-Shot plus loop modes and wavetable / granular synth.
Aid	Zoom	6th	Variable	Zooms in horizontally to the visual display for more precise editing. Does not affect playback. Zoom reference point is based on the previously adjusted parameter i.e. Start.
Aid	Preview	1st	Variable	Hold to play the sample. The number below the screen button label indicates current play position in seconds. Preview playback will run for approx 1 sec after releasing the preview button.
Edit	Start	2nd	Variable	Adjusts and edits the sample start point. This is the starting position used when a 1-shot sample is triggered in a pattern or when previewed. Marker is red but will change to green if a zero crossing point is detected at the current position.
Edit	End	5th	Variable	Adjusts and edits the sample end point. This is the ending position used when a 1-shot sample is triggered in a pattern or when previewed. Marker is red but will change to green if a zero crossing point is detected at the current position.

6.8 Loop Play Modes

Three loop playback modes exist, forward loop, backward loop and pingpong loop. All of these three play modes have similar functions and only differ in their playback direction.

The note value, tempo and pattern length will also affect how the sample plays. A higher note value will play the sample faster. A lower note value will play the sample slower. Triggering the instrument step will trigger the sample once and it will continue to play for its duration in loop until another trigger is initiated or the pattern ends.

NOTES

NOTES

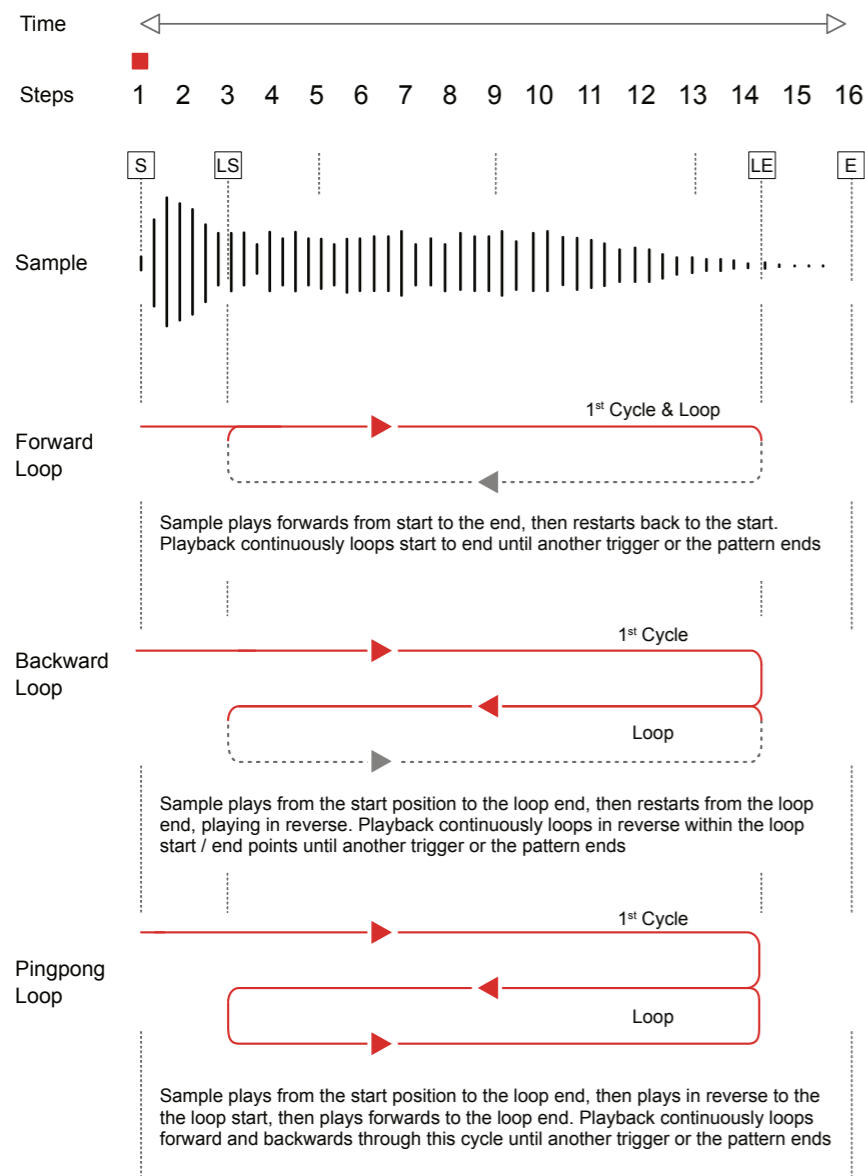

■ Sample playback is initially triggered and while ever the pattern plays it will continue to loop.

Loop Parameters

The parameters for the forward loop, reverse loop and pingpong loop play are identical across these play modes. Options are start / loop start, end / loop end plus the zoom visual aid. Navigate and select using the Screen Buttons. Also navigation using the [Left] [Right] buttons to select the section and [Up] or [Down] or Turn (Jog) to change the value / selection.

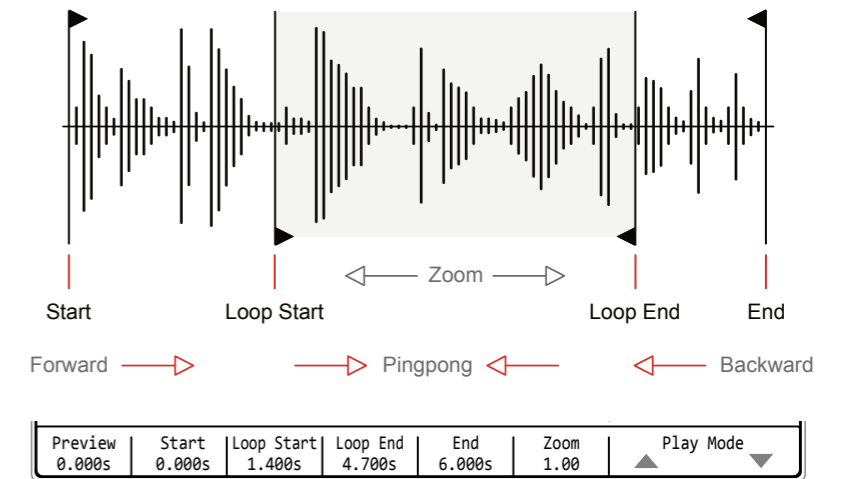

Function	Parameter	Screen Button	Range	Description
Edit	Play Mode	7th & 8th	Modes	Selects the play mode to apply. Includes forward loop, backward loop, pingpong loop as well as 1-Shot and wavetable / granular synths.
Aid	Zoom	6th	Variable	Zooms in horizontally to the visual display for more precise editing. Does not affect playback. Zoom reference point is based on the previously adjusted parameter i.e. Start.
Aid	Preview	1st	Variable	Hold to play the sample. The number below the screen button label indicates current play position in seconds. Preview playback will run for approx 1 sec after releasing the preview button.
Edit	Start	2nd	* Lower than End	Adjusts and edits the sample start point. This is the starting position when the sample is first triggered in a pattern or when previewed. Red marker turns green at a zero crossing point.
Edit	Loop Start	3rd	* Higher than Start	Adjusts the sample loop start point. This is the start position used on the 2 nd and subsequent playback cycles, playing from loop start to loop end. Value will always be same or higher than start position. Red marker turns green at a zero crossing point.
Edit	Loop End	4th	* Lower than start	Adjusts the sample loop end point. This is the end position used for playing a loop. Value will always be same or lower than end position. Red marker turns green at a zero crossing point.
Edit	End	5th	* Higher than Start	Adjusts and edits the sample end point. The ending position, outside of a loop when a sample is triggered in a pattern or when previewed. Red marker turns green at a zero crossing point.

* Start / End, Loop Start / End Positions cannot cross over. Start is always before end.

6.9 Slice Play Modes

Two slice playback modes exist, slice and beat slice both of which have similar functions and parameters.

Slice mode is typically used to slice a melodic audio sample, for example to create pitch based kits and to trigger slices per step from the FX, 'S' step function. The pads in Slice mode represent current scale.

Beat Slice mode is typically used to slice percussive and atonal samples. The pads in Beat Slice mode represent individual slices, for example hits of a drum kit and are useful for playing and recording live beats.

Slice
Examples: Synth Note, Piano, String Pad

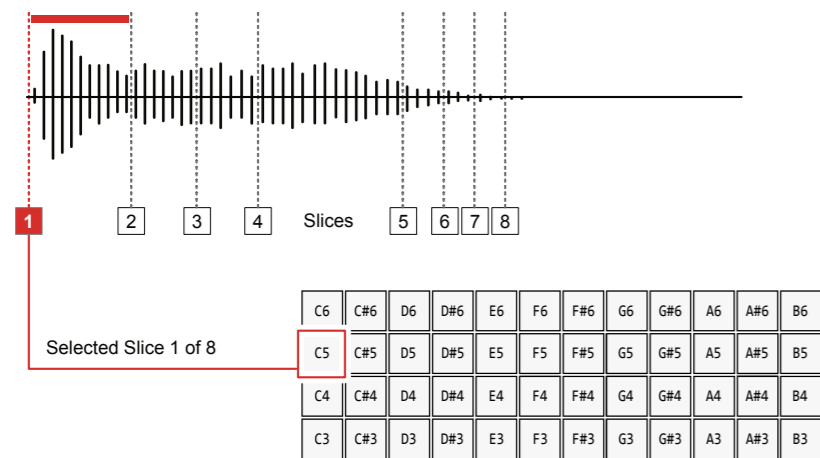

Pads play the selected slice melodically in the current pitch scale.

Beat Slice
Examples: Combo of Kick, Snare, Hat, Effects

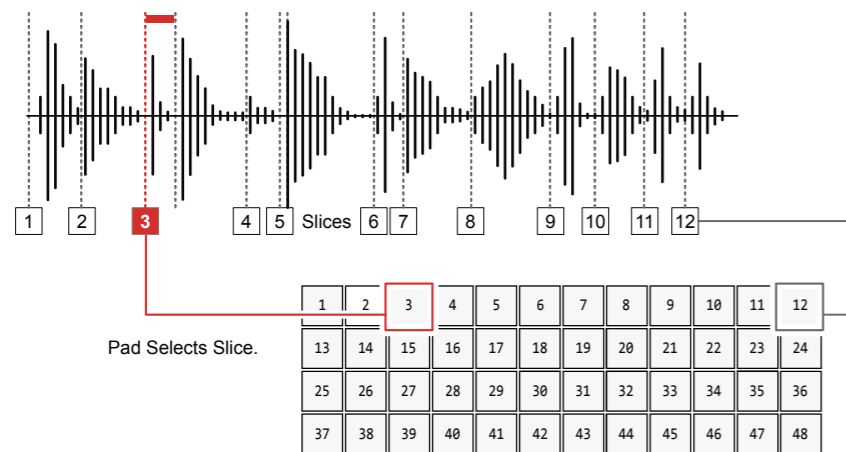

Pads select and play each slice individually. Ideal for recording beats.

NOTES

NOTES

Slice Parameters

The parameters for slice and beat slice are identical across the play modes but may have different behaviours in use. Navigate and select using the Screen Buttons. Also navigation using the [Left] [Right] buttons to select the section and [Up] or [Down] or Turn (Jog) to change the value / selection.

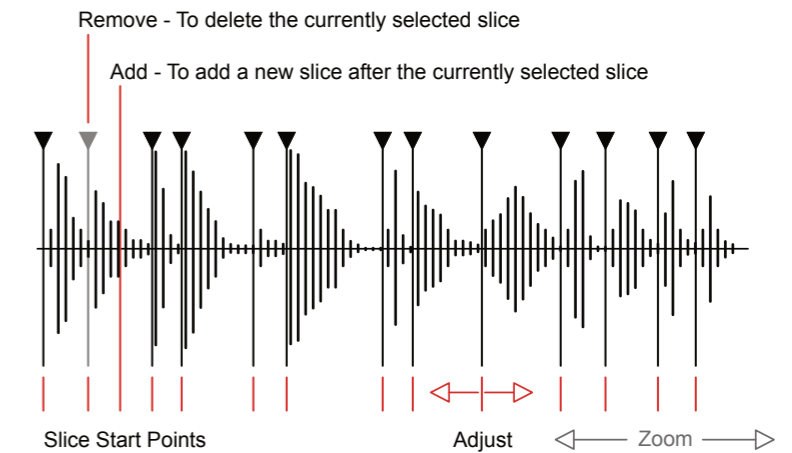

Function	Parameter	Screen Button	Range	Description
Edit	Play Mode	7th & 8th	Modes	Selects the play mode to apply. Includes Slice and Beat Slice as well as 1-Shot and wavetable / granular synths and loop modes.
Aid	Zoom	6th	Variable	Zooms in horizontally to the visual display for more precise editing. Does not affect playback. Zoom reference point is based on the previously adjusted parameter i.e. Slice number.
Edit	Slice	1st	Variable	Selects the slice number for editing from the available number of slices. Also will select the slice to playback in scale when in Slice Play Mode. Use Pads to preview playback and also to select the slice in Beat Slice Play Mode.
Edit	Adjust	2nd	Variable	Adjusts the start position for the selected slice. Cannot exceed the previous or next slice position. Use zoom to assist with precise editing. Red marker turns green at a zero crossing point.
Edit	Add	3rd		Adds a new slice after the currently selected slice start marker. Slice will be added centrally between the currently selected slice start and next slice start or end position.
Edit	Remove	4th		Removes and deletes the currently selected slice start marker. No prompt - immediate deletion.
Edit	Auto Slice	5th	Automatic	Automatically removes any existing slice markers and adds a series of new markers at each transient point. Prompt to confirm is given.
Edit	Number	Shift + 1st	1 - 48	Sets the number of slices to create when using the 'equal' slice option. This applies the number of equally spaced slices across the sample.
Edit	Equal Slice	Shift + 2nd		Initiates slicing of the sample into the equal spaced slices, set by 'number'. Prompt to confirm.

SLICING A SAMPLE

1. Ensure the desired instrument is selected with the sample to edit. This will be shown top right of the screen.
2. Press [Sample Playback] to select the playback mode pages.
3. Press the 7th or 8th Screen Button to navigate to 'Slice' or 'Beat Slice' Play mode depending on the function required.
4. To slice the sample, follow one or a combination of the slicing techniques. Up to 48 slices are possible:
 - a. Transient Slicing. Will automatically slice the sample into a number of slices located at the points where a dynamic amplitude change is detected. The number of slices is based on the number of transients detected.
 - Press [Auto Slice], 5th Screen Button and acknowledge when prompted. Existing slices are cleared and new ones created.
 - b. Equal Slicing. This will slice the sample in a set number of equally spaced positions. Amount of slices set by the 'Number' value. Hold [Shift] to access this feature.
 - Hold [Shift] + [Number], 1st Screen Button and Turn (Jog) to set number of slices to create.
 - Hold [Shift] + [Equal Slice], 2nd Screen Button while still holding [Shift]. Acknowledge on prompt. Existing slices are cleared and new equidistant slices are created.
 - c. Manual Slicing. This will add 1 slice at the central point between the currently selected slice start marker and the following slice start.
 - Select a slice, Press [Slice], X of Y, Where X is the selected slice and Y the total number of slices available. This is the 1st Screen button.
 - Turn (Jog) to select the slice number.
 - Press [Add], 3rd Screen Button. The new slice is added. If no slices are present a new one is added at the sample start position.
 - Any new slice added automatically becomes the currently selected slice.

NOTES

NOTES

REMOVING A SLICE

1. Press [Sample Playback] to select the playback mode pages.
2. Press the 7th or 8th Screen Button to navigate to 'Slice' or 'Beat Slice' Play mode depending on the function required.
3. Select a slice, Press [Slice], 1st Screen button. X of Y, Where X is the selected slice and Y the total number of slices available.
4. Turn (Jog) to select the slice number to delete.
5. Press [Remove], 4th Screen Button. The selected slice is deleted immediately (no prompt) and the currently active slice reverts to the previous slice.

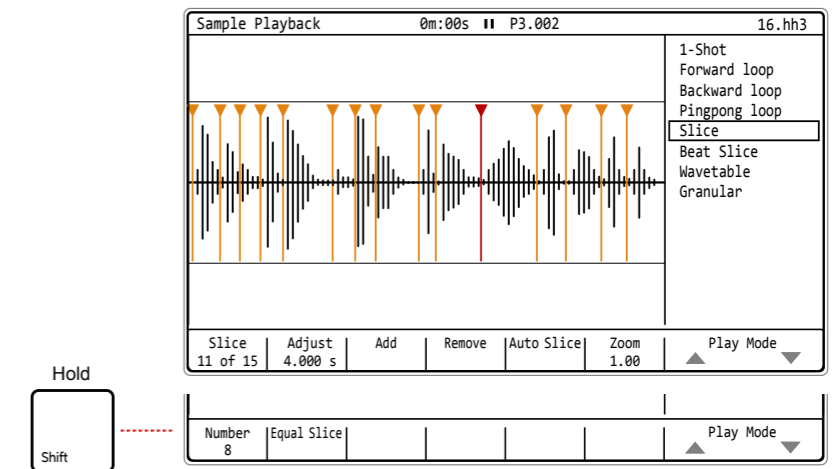

ADJUSTING A SLICE POSITION

1. Press [Sample Playback] to select the playback mode pages.
2. Press the 7th or 8th Screen Button to navigate to 'Slice' or 'Beat Slice' Play mode depending on the function required.
3. Select a slice, Press [Slice], 1st Screen button. X of Y, Where X is the selected slice and Y the total number of slices available.
4. Turn (Jog) to select the slice number to edit.
5. Press [Adjust], 2nd Screen Button. Zoom may help create precise edits.
6. Turn (Jog) or Press [Up] or [Down] to adjust the slice start position.

6.10 Wavetable Play Modes

Wavetable instruments can be created in Tracker. This emulates classic wavetable synthesizers by using a sample as the wavetable source. Standard Tracker samples can be used 'out of the box' or samples prepared specifically to suit the application in a wavetable synth and give better performance. While Tracker offers only a basic implementation of wavetable synthesis it does bring a different creative option into the instrument library.

What is Wavetable Synthesis?

The most common synth model is subtractive synthesis. This is based on a sound source, typically using one or more oscillators, tuned in various ways. The sound is then shaped and carved by filtering out (subtracting) frequencies, applying envelopes and adding effects. Wavetable synths typically follow these same principles but the 'oscillator' is formed from a series of wave-shapes called wavetables. In reality, a wavetable consists of a number of stacked samples called frames, the accepted standard being 256 frames.

Navigating or modulating through the almost endless wave positions and selecting 'single cycles' in the wavetable is a fundamental element in wavetable sound design. In Tracker the wavetable size (samples per frame) is set by the 'Window' parameter. Think of this as the length of the available table, the default maximum being defined by the original audio sample format. The specific 'Position' within the wavetable is also selectable and important in the sound design process. Position can also be modulated.

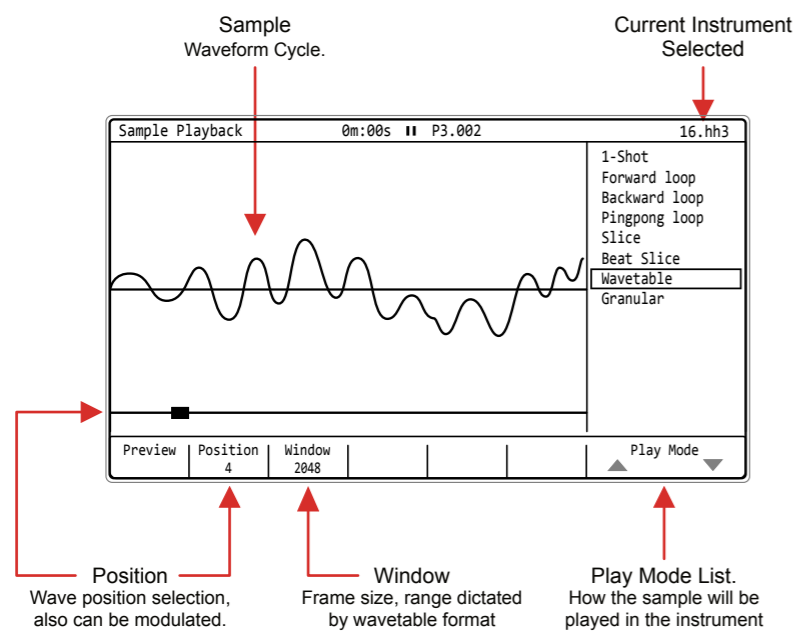

NOTES

NOTES

Wavetable Parameters

The wavetable play mode is a simplified application of wavetable synthesis and consists of two core parameters. The Window is the wavetable length (samples per frame) and has a maximum value based on the original file. The position parameter is what enables the creative sound design and audio manipulation. This can be manually adjusted to find a sweet spot or modulated with the envelope or LFO.

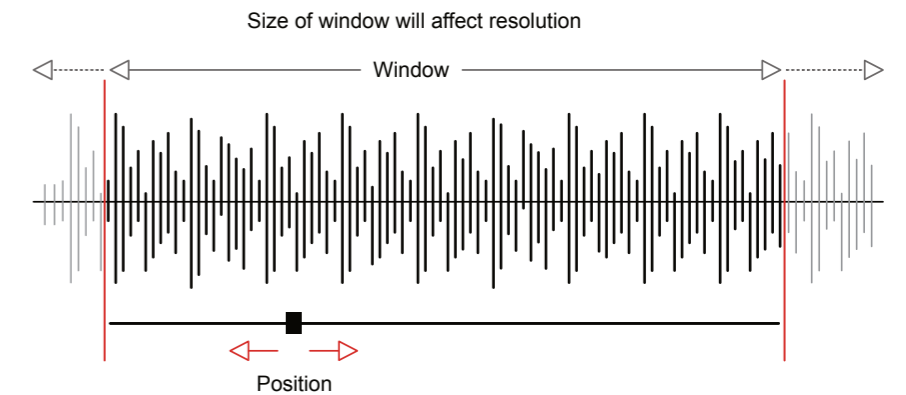

Function	Parameter	Screen Button	Range	Description
Edit	Play Mode	7th & 8th	Modes	Selects the play mode to apply. Includes Wavetable and Granular as well as 1-Shot and the three loop modes.
Aid	Preview	1st		Hold to play the wave from the current position selected in the window. Also hold while adjusting position to 'scan' for the desired sound.
Aid	Window	3rd	Variable	The width of the wavetable can be adjusted down from the default maximum. The parameters are normally divisions of 2 down from the maximum (Typically 2048)
Edit	Position	2nd	Variable	Selects the playback position within the wavetable window. This can be manually adjusted to find the desired 'sweet spot' or modulated with an LFO or Envelope for movement and interest.

Optimising Wavetables

The best approach to operating with wavetable synthesis is to use WAV files that have been created for wavetable use. This will adhere to the frame / sample conventions stated. Also the audio samples will be created with smooth rather than stepped transitions between waves. There are many pre-prepared wavetables available for download but also check out the online [sheets of sound](#) creator and Modbap Modular [OsirisEdit](#) to learn more about wave creation.

Tracker's factory wavetable files are located in the samples folders on the SD Card.

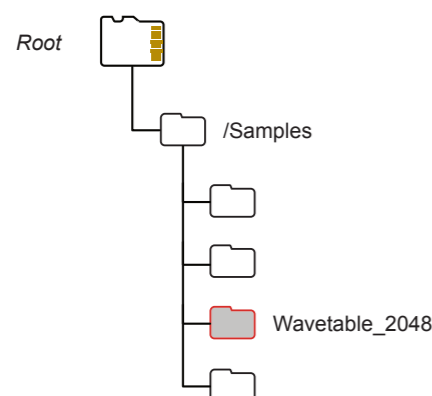

There are many freely available wavetable samples online. Standard samples can be used but wavetable formatted WAV files provide better and smoother performance. The most common standard is 2048 Samples / Frame (256 Frames). This applies to XFer Serum, U-He Hive, Dune, but others may also exist. Ableton Live Wavetable uses 1024 samples and down samples when a 2048 format is applied.

NOTES

NOTES

Standard audio files may sound 'stepped' when navigating the position. Tracker has an on-board optimisation tool, WT Smoother which will process a standard sample and help smooth the sound and give better performance. This effectively converts the file to a more suitable format for Tracker's Wavetable Synth. Navigating a processed audio wave will sound smoother in the transition across positions.

■ USING WT SMOOTHER TO OPTIMISE SAMPLES

1. Ensure the sample is loaded to the instrument list and selected as currently active. Note that samples in the instrument list are copied into the onboard memory from the SD Card.
2. Press [Sample Editor] to select the playback mode. Operations in the 'Sample Editor' are performed destructively to the sample in memory. However the original file is retained intact on the SD Card.
3. Edit the audio file [Start], 1st Screen button and [End], 2nd Screen Button and Turn (Jog) to select a part of the sample to process.
4. Press the 7th or 8th Screen button to navigate to 'WT Smoother'.
5. Press [Select effect], 6th Screen button to select WT Smoother.
6. Press [Window Num], 1st Screen button and Turn (Jog) to adjust. This selects frames. The 256 default is a typical setting to use.
7. Press [Window Len], 2nd Screen button and Turn (Jog) to adjust. This selects sample length. The 2048 default is a typical setting to use.
8. Press [Preview], 7th Screen button to audition the audio while editing. This will need to process the audio before playing. Press [Stop], 7th Screen Button again to stop preview.
9. Press [Apply], 8th Screen button to apply and render the new audio file. This converts to a wavetable and can be used in the wavetable play mode as a smoother more refined option.
10. Save the project to also save the edited instruments in the project folder. Press [File] then Press [Save], 5th Screen Button. Saving the project also automatically saves the instruments in the instrument subfolder. These can be accessed from other projects.

Modulating Wavetables

The wavetable position is the key parameter to adjust and edit to search for a desired sound. This parameter can also be modulated from within the instrument automation page using an envelope or LFO. This adds movement and interest.

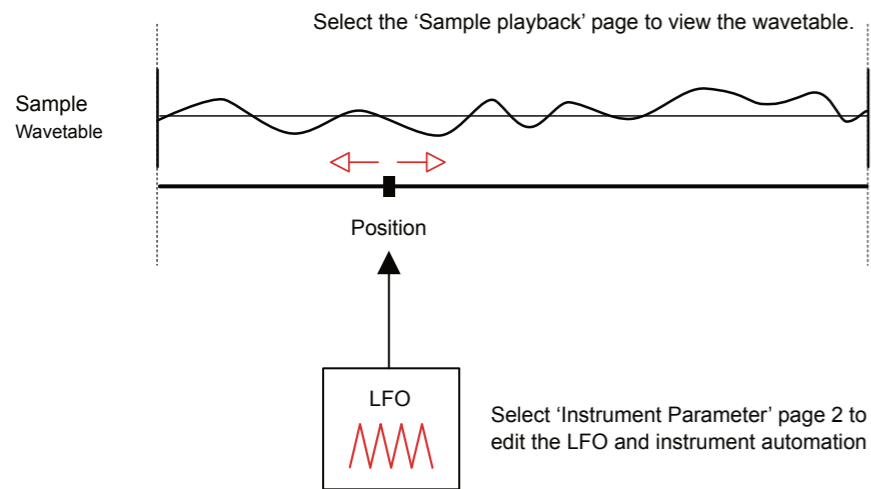

Hold [Preview] in the wavetable page while the LFO is running will display the animated position dynamically in real time.

Fast LFO Speeds can create glitchy and noisy sound designs. Use slower LFO speed or envelope and reduce the wavetable window for developing sound textures and ambience especially with added effects such as reverb. Try synchronised speeds to tempo / steps to create rhythmic patterns. The LFO amount will also effect how strong the LFO is applied.

Try manually adjusting the window and position while playing and with an LFO to experiment with the sound.

NOTES

6.11 Granular Play Modes

Granular instruments can be created in Tracker. As with all Tracker instruments, Granular synth uses a sample as its core sound source. Granular synthesis is ideal for glitchy soundscapes and textural sounds.

What is Granular Synthesis?

Granular synthesis breaks a sample down into tiny slices, lets describe this as microscopic level. These narrow slices are generally less than 1 second but often much shorter in duration and are called grains. Sound is generated in a granular synthesizer by looping playback around a grain. It is common practice to use modulation to bring a granular synth to life especially using grain position. Granular synths can still use the same features as in subtractive synthesis including filter and envelopes.

Modulating grain position is at the heart of the Tracker's implementation of granular synthesis where an LFO or envelope can be used. The position can be set manually within its parameters as can length with a range up to 1000ms. Also shape and loop direction of playback parameters can also be adjusted manually in the Granular synth playback mode.

NOTES

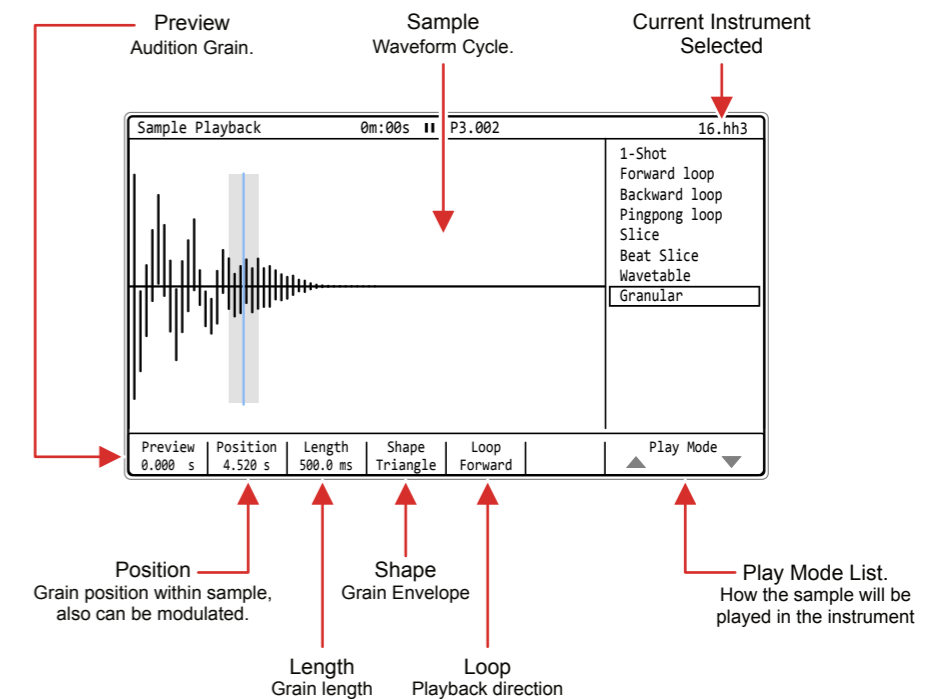

Granular Parameters

The granular play mode is a simplified application of granular synthesis and consists of four core parameters. The grain length is duration of the small slice of audio, while loop defines the direction of playback across the grain. Shape is the envelope shape applied to the grain playback, recognised in the attack phase. The position parameter is what brings out the its sonic character. This can be manually adjusted to find a sweet spot or modulated with the envelope or LFO to introduce movement and interest. Tracker operates with a single grain.

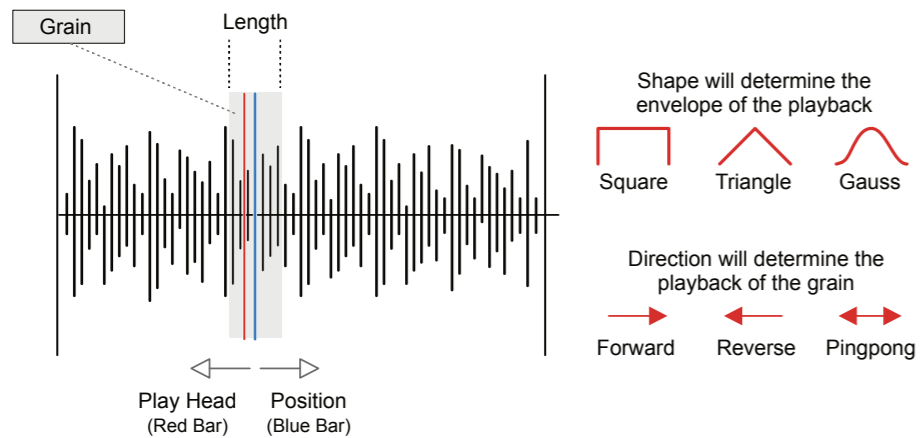

Function	Parameter	Screen Button	Range	Description
Edit	Play Mode	7th & 8th	Modes	Selects the play mode to apply. Includes Wavetable and Granular as well as 1-Shot and the three loop modes.
Aid	Preview	1st		Hold to play the grain from the current position selected. Also hold while adjusting position to 'scan' for the desired sound.
Edit	Position	2nd	Variable	Selects the grain playback position within the sample. This can be manually adjusted to find the desired 'sweet spot' or modulated with an LFO or Envelope for movement and interest.
Edit	Length	3rd	1-1000ms	Sets the width in ms of the grain. This will be the small slice of the sample that is played.
Edit	Shape	4th	Square, Triangle, Gauss	Sets the envelope shape for the grain playback. Particularly pertinent in the attack phase.
Edit	Loop	5th	Forward, Reverse, Pingpong	Selects the grain playback direction.

NOTES

NOTES

Modulating Granular Position

The granular position can be modulated from within the instrument automation page using an envelope or LFO. This adds movement and interest and creates glitchy or textural sounds

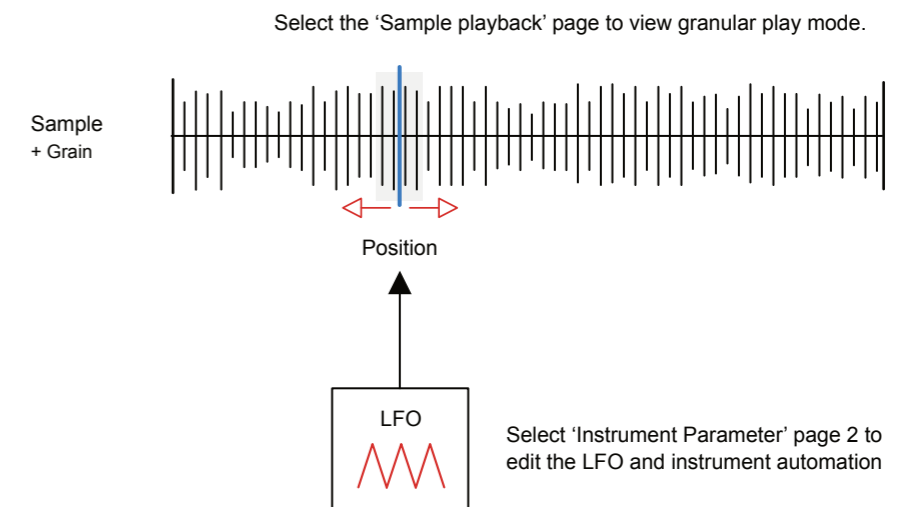

Hold [Preview] in the granular page while the LFO is running will display the animated position dynamically in real time.

The LFO Speed and granular parameters can have an affect on the sound developed. Also the LFO amount will determine how much of the sample is navigated with varying the position. Small amounts will be more predictable textures and pad like sounds. Larger amount settings will move the position wider in the sample creating more glitchy, less predictable sounds.

6.12 Sharing Instruments

Instruments can be shared either with other projects on the same device or by transferring to another Tracker. This is useful when developing new instruments or ones which will be reused for example to develop a signature sound across multiple tracks of an album.

Instruments are saved with a project using a '.pti' file format and are stored in the project subfolder, 'instruments'. The project and instrument folders are accessible from all projects. This is ok if you know where to look and what to look for. Remembering all projects and their instruments is not an easy task. A few tips will help manage a library of instruments. Tracker does not have in depth file management functions on board so using a PC or Mac to access the SD card is required.

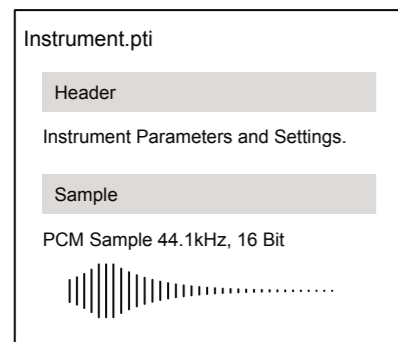

A .pti file contains a header ~400 bytes which handles the parameter settings. In addition a sample is included which can vary in size and which is packed into the instrument file.

- Create instruments as normal. Save a project which will also save the instruments into the current project folder. Instruments created or loaded from other projects will be saved with the current project.
- Consider creating a 'user' subfolder within the instruments folder. This can be used to build a library of user instruments.
- A different folder cannot be selected in Tracker when saving Instruments. Periodically instruments can be manually copied using a PC / Mac into the 'user' instrument folder on the SD card. This would be a housekeeping task, maybe combined with backing up the SD Card fully.
- Do not cut or delete the the original instrument from the project as this is where the project recognises the original file to be stored.
- The user folder can easily be shared with collaborators or between devices simply by copying between SD Cards with the PC / Mac.

NOTES

NOTES

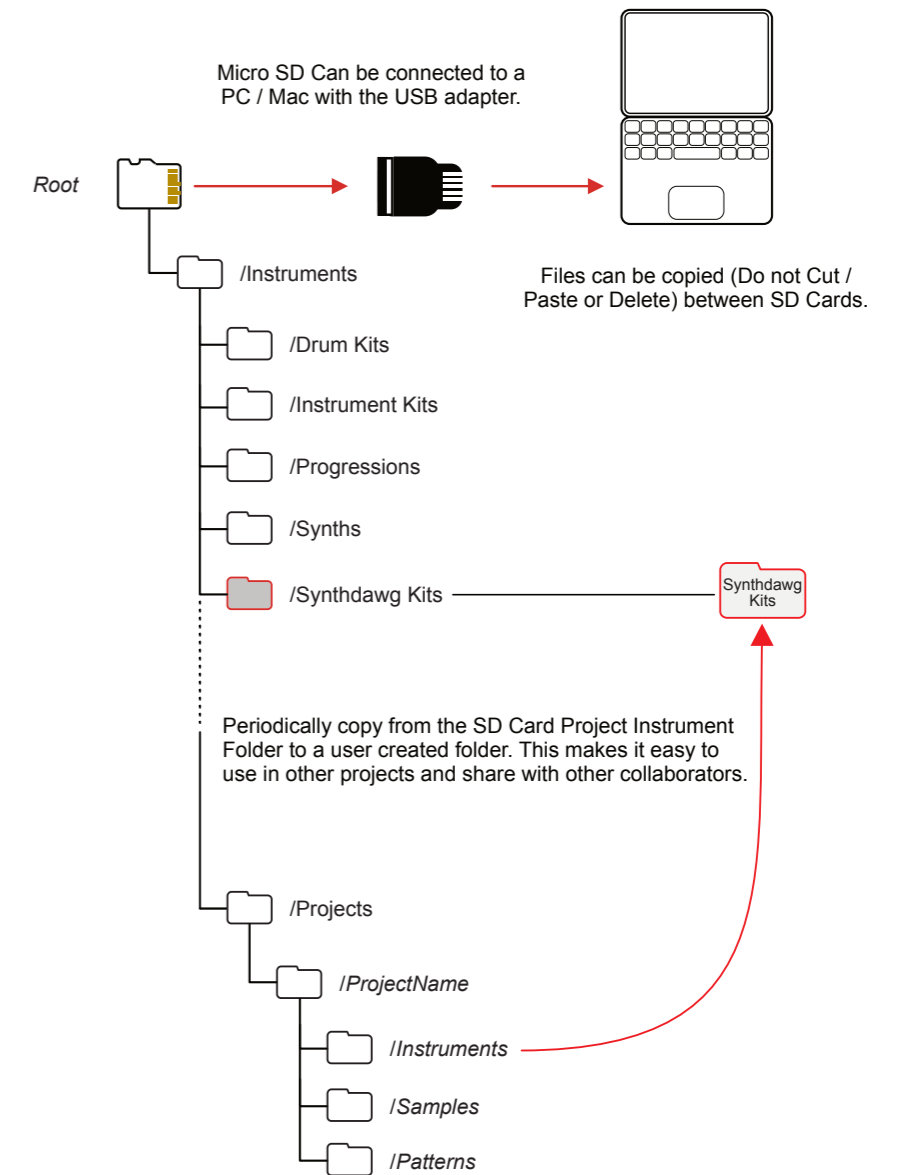

Consider a naming convention for user instruments. This is less important when using project contained instruments, but this technique can be helpful when managing a user library. Instruments can be renamed in the 'sample loader' page. It is advised to always keep a discipline of naming instruments in Tracker rather than on the PC/Mac to protect the .pti file integrity and to make future access easier.

FX Steps

It is important to get a good understanding of all four elements of a step. This will help to get the most from step sequencing. This section provides a deeper dive into the two FX slots. FX slots have access to a library of 37 effects that are applied in a somewhat different way to the normal expectation. These can apply both audio and MIDI applications to modulate and control as well as traditional effects such as delay. These can be applied step by step giving intimate control over each step and when built together with other steps offers a very creative option in Tracker. These are very powerful and without doubt are worth the time and learning investment to get to know the range and application of effects available. It is important to recognise that step effects are different to the general instrument and master effects provided. These work in a more traditional, inline and send configuration while the step FX are polarised to the step itself or to

the pattern in which it is operating. Some step FX are even applied to all tracks for example Tempo. The help descriptions that is provided for each individual effect and found in the Tracker FX selection page is somewhat useful, but only as a quick reference. This section aims to take a FX focussed view and gives a more detailed reference along with some practical and simple examples of applying FX into a pattern.

7.1 Step FX Descriptions

Step FX are a collection of 37 effect types that can be applied into one of two step locations using the dedicated Step FX buttons. Creative step patterns can be generated by applying and also combining. FX do not always need a note and instrument in the same step event. For example, filter cutoff can adjust the cutoff value, applied to previous triggered note. The Step library also provides some brief information on each effect.

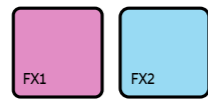

Step	Chord	Pattern	FX	Description
1	C5 40	P-25	C5 40 H-25	None
2	C5 40	P-25	C5 02 P-20	None
3				None
4				None
5				None
6				None
7				None
8				None
9				None
10				None
11				None
12				None
13				None
14				None
15				None

ACCESSING THE EFFECT DESCRIPTIONS

1. Press [Pattern] to select the pattern mode page.
2. Select a blank or existing step event.
3. Hold [FX1] or [FX2] + Press Screen Button 7 or 8. This toggles the description window open or closed.
4. Scroll to select effect while holding the FX button + Turn (Jog). The description provided will represent the FX highlighted in the list.
5. If in REC mode the FX will be selected for the step from within this menu list.

When adjusting the value with the jog control for an FX slot with an instrument loaded to the step, the audio applied through the effect will be automatically previewed.

NOTES

NOTES

7.2 Step FX Reference

The effects are contained into a library of 37 FX types which can be selected into the step. The details for each effect varies depending on its function. Also the interaction with other steps or the note or instrument may be relevant for some effects. The descriptions are built into the FX menu, but these are limited in the descriptions. A deeper understanding of the FX is beneficial and brings more clarity to what at first glance can be confusing.

One effect can be loaded into a step FX slot. Each step has 2 FX slots so a total of two FX are possible. While this may seem limiting it is worth remembering that some traditional effects also exist in the audio signal chain. For example delay. The FX should be considered more like mini applications that not only affect the audio but also affect the behaviour of the step and sometimes the pattern itself.

This section and following parts will hopefully demystify their use, especially within pragmatic use case examples.

Affects Audio Sound.	Affects Step Behaviour.	Affects Structure / Timing
V Volume	- None	T Tempo
P Panning	! Off	I Swing
M Micro Tuning	C Chance	m Micro Timing
n Random Note	R Roll	G Glide
i Random Instrument	f Random FX	q Gate Length
v Random Volume	S Slice Playback of Sample	A Arpeggiator
r Reverse Sample		a - f MIDI Out
P Position in sample / wave		F Slide Up
g Volume LFO Rate		J Slide Down
h Panning LFO Rate		0 MIDI Chord
j Filter LFO Rate		
k Position LFO Rate		
I Finetune LFO Rate		
D Overdrive amount		
L Low Pass Filter		
B Band Pass Filter		
H High Pass Filter		
s Delay Send		
t Reverb Send		
E Bit Depth		
U Tuning		

7.3 None

FX Type Tag	Effect
-	None - No FX Applied

FX Description
 No effect is applied and hence the sound for the step will purely be based on the instrument and note. This is basically an empty effect.

Value Ranges	Pad Range
N/A	N/A

Example
 Default state for any step is that the FX1 and FX2 are empty. This effect can be applied to remove an existing FX and reset to the normal empty state.

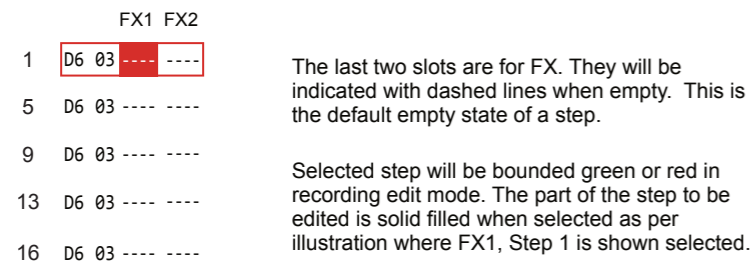

NOTES

7.4 Off

FX Type Tag	Effect
!	Off

FX Description
 Will deactivate an effect that has been triggered on a prior step.

Value Ranges	Pad Range
On	Any pad will apply the Off command

Example
 A roll triggered on step 1 will be audible over the subsequent following steps. Applying an !OFF step command afterwards will curtail the effect for the track.

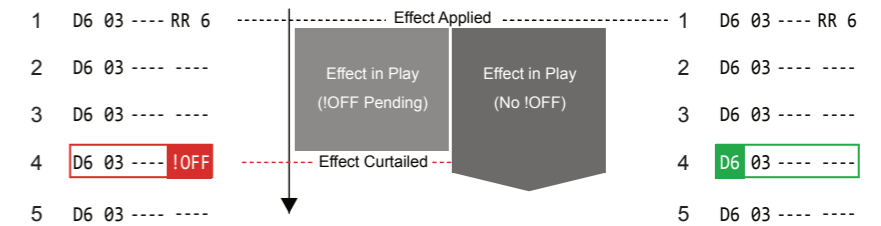

NOTES

7.5 Volume

FX Type Tag	Effect
V	Volume / Velocity

FX Description

Will apply a volume level for this individual instrument step.
For MIDI this will send a NOTE ON Velocity parameter.

Value Ranges

0 - 100%
Pad 1 = 0%, Pad 13 = 25%, Pad 25 = 51%, Pad 37 = 76,
Pad 48 = 100%

Example

To illustrate an example, 16 Steps with volume ramped up through the pattern steps. This will be a stepped ramp. To create a smoother ramp try using the fill function to populate all steps using 'From-To' or Live Rec. This will still be triggered per step but will be audibly smoother.

1	D6 03 ---- V 0	1	D6 03 ---- V 0
5	D6 03 ---- V 30	2	D6 03 ---- V 6
9	D6 03 ---- V 55	3	D6 03 ---- V 13
13	D6 03 ---- V 80	15	D6 03 ---- V 94
16	D6 03 ---- V100	16	D6 03 ---- V100

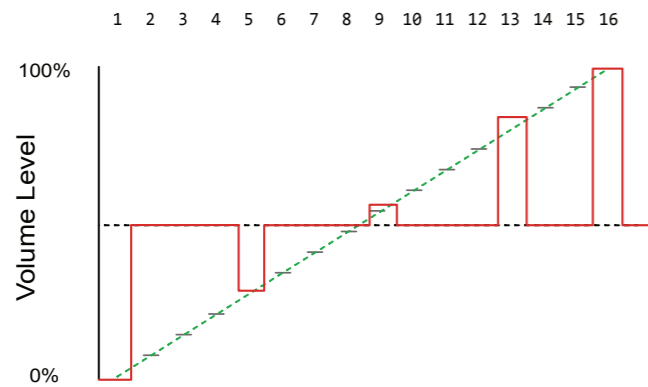

NOTES

7.6 Panning

FX Type Tag	Effect
P	Panning

FX Description

Positions the audio within the stereo field, panning the signal in the left / right position. This is applied per step.

Value Ranges

L -50 - R +50
Pad 1 = -50, Pad 13 = -25, Pad 25 = +1, Pad 37 = +26,
Pad 48 = +50

Example

An example of 16 Steps panned left to right and then back to left. Triggered for the stereo position per step. To create a smoother, less stepped transition use fill to populate all steps using 'From-To'.

1	D6 03 ---- P-50	1	D6 03 ---- P-50
5	D6 03 ---- P 0	2	D6 03 ---- P-42
9	D6 03 ---- P 50	3	D6 03 ---- P-31
13	D6 03 ---- P 0	15	D6 03 ---- P-38
16	D6 03 ---- P-50	16	D6 03 ---- P-50

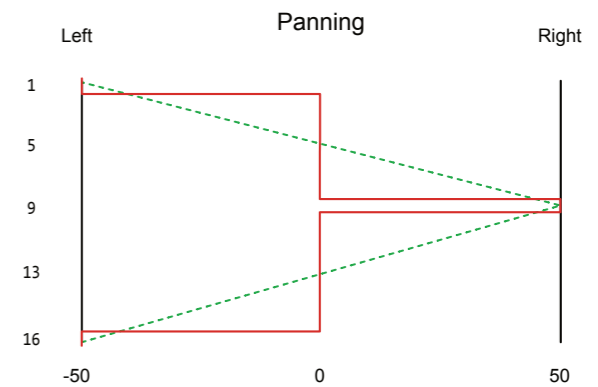

NOTES

7.7 Micro-Tune

FX Type Tag	Effect
M	Micro Tuning

FX Description
 Applies a fine tuning pitch adjustment for the step note or MIDI output. Operates in cents, where 100 cents is one semitone

Value Ranges	Pad Range
-99 to +99 Cents	Pad 1 = -99, Pad 13 = -49, Pad 25 = +2, Pad 37 = +52, Pad 48 = +99

Example
 A semitone is 100 cents but as the tuning is so fine, the maximum range of micro tuning is almost a full semitone. This can be used to add variation especially with percussive sounds while still maintaining musicality.

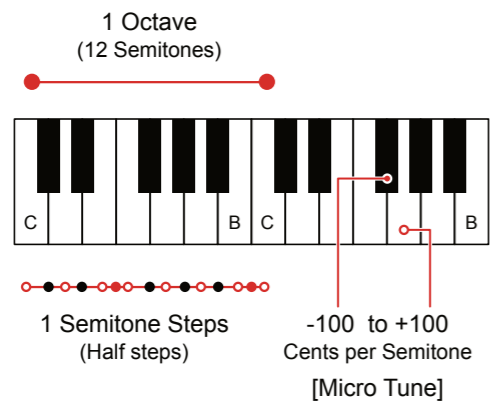
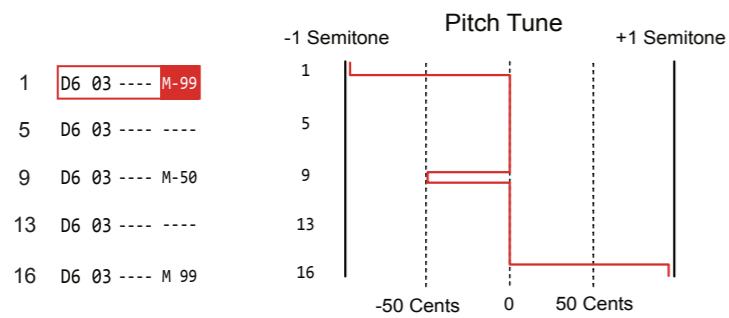

NOTES

7.8 Glide

FX Type Tag	Effect
G	Glide

FX Description
 Creates a smooth transition when the step is activated, from the pitch of a previous note value to the current step note value over a time period based on the glide time setting. Glide time is in percentage which represents time.

Value Ranges	Pad Range
0 - 100%	Pads 1 - 24 = 0 - 48% (0 to ~1 Sec), Pads 25 - 48 = 49 - 100% (~1s - 15 Secs)

Example
 A short or long glide time transition can bring a creative effect using the pitch of a step note. Try experimenting by using glides in combination with other steps.

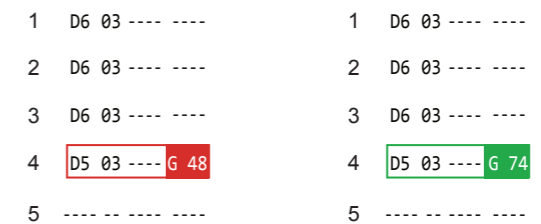

Step Trigger D6 D6 Step Trigger
 Glide from prior note D6 to Note D5 across the glide time duration.



Glide Time Converter (Estimated)

%	0	13	25	36	50	55	60	65	70	75	80	85	90	95	100
Sec	0	0.25	0.5	0.75	1.0	2.4	3.8	5.2	6.6	8.0	9.4	10.8	12.2	13.6	15

NOTES

7.9 Tempo

FX Type Tag	Effect
T	Tempo Change

FX Description

Applies a % tempo change triggered on the step. TSTP Tempo Stop - Stops the sequencer running. Given that MIDI is synchronised to the project tempo, this will also affect MIDI Out clock.

Value Ranges	Pad Range
10 - 400%	Pad 1 = TSTP, Pad 13 = 108%, Pad 25 = 208%, Pad 48 = 400%. Jog is more precise in use.

Example

Tempo change is applied to the entire pattern from the step onwards. A TSTP command, applied with (Jog) left, will add a full stop step which will halt the sequencer. Default tempo of 120 for this example.

Example 1.

```

1 D6 03 ----
5 D6 03 ----
9 D6 03 ---- T200
13 D6 03 ----
16 D6 03 ----
    
```

Example 2.

```

1 D6 03 ----
5 D6 03 ---- T 50
9 D6 03 ----
13 D6 03 ---- TSTP
16 D6 03 ----
    
```

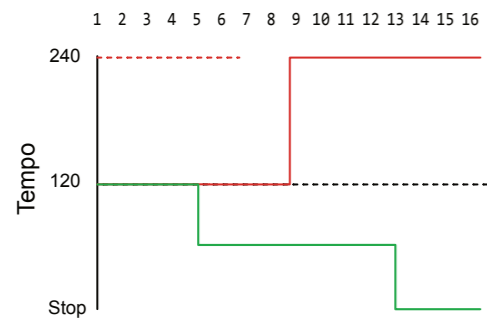

Example 1.
Pattern will play first cycle and trigger the tempo change on step 9. The entire pattern tempo will change and continue through subsequent pattern cycles until a new tempo is triggered or set.

Example 2.
Pattern will play at the defined tempo, change when triggered then the pattern will stop when the TSTP event is activated.

NOTES

7.10 Swing

FX Type Tag	Effect
I	Swing

FX Description

Introduces a groove or shuffle into the pattern timing. 50% is no swing. Range is 25% to 75% of pattern swing. Also applied to MIDI Out.

Value Ranges	Pad Range
25 - 75%	Pad 1 = 25%, Pad 13 = 37%, Pad 25 = 50%, Pad 37 = 63%, Pad 48 = 75%

Example

Swing on a step track will apply across the pattern. These can create a groove. Maybe experiment with variations. Adjust by ear rather than numbers.

1	D6 03 ---- I 55	1	D6 03 ---- I 45
5	D6 03 ---- P 0	5	D6 03 ----
9	D6 03 ---- P 50	9	D6 03 ---- I 35
13	D6 03 ---- P 0	13	D6 03 ----
16	D6 03 ---- P-50	16	D6 03 ----

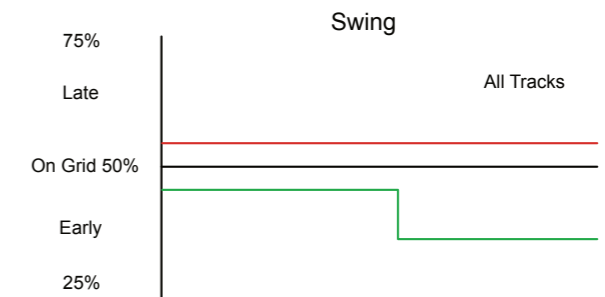

NOTES

7.11 Micro Move

FX Type Tag	Effect
m	Micro Move

FX Description

Will apply a small offset to the note step. This will move the note forward by an amount based on the setting.

Value Ranges

Pad Range
0 - 100%
Pad 1 = 0%, Pad 13 = 25%, Pad 25 = 51%, Pad 37 = 76%, Pad 48 = 100%

Example

Can be used to offset one part of a track step or provide minor step variations. Think of this similar to swing, but applied to a step rather than pattern.

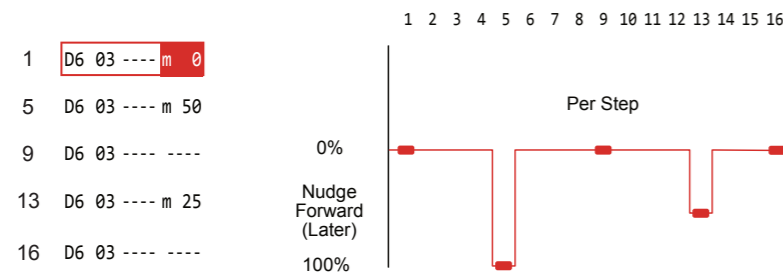

While the range is 0-100%, the actual shift of notes is only in small amounts. The 0% setting is 'On Grid' while any nudge is forward in the pattern.

NOTES

7.12 Gate Length

FX Type Tag	Effect
q	Gate Length

FX Description

Adjusts the length of the note gate and helps shape the sound. Operates in conjunction with the instruments Envelope settings which are found in the 'Instrument's Parameters'.

Value Ranges

Pad Range
0 - 100%
Pad 1 = 0%, Pad 13 = 25%, Pad 25 = 51%, Pad 37 = 76, Pad 48 = 100%

Example

Increases or reduces the gate for the note. This works with the envelope and will determine length of note helping to shape the sound over time.

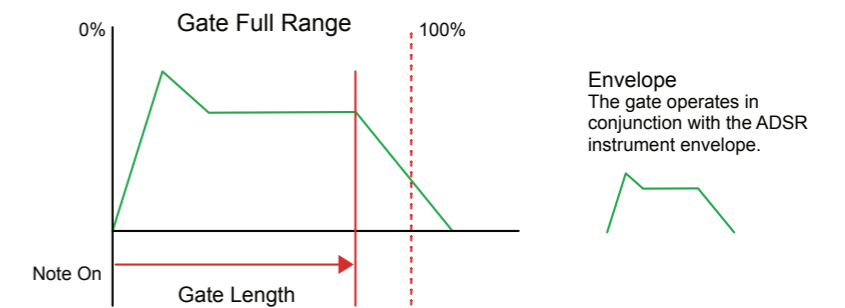

NOTES

7.13 Chance

FX Type Tag	Effect
C	Chance

FX Description

Sets the chance condition for the step. This will apply a probability of whether the step will play or not. Higher percentages means a higher chance of playing. 100% will always play, 0% will never play.

Value Ranges

Pad Range
0 - 100%
Pad 1 = 0%, Pad 13 = 25%, Pad 25 = 51%, Pad 37 = 76, Pad 48 = 100%

Example

Can add variation to a pattern. For example a percussive note sequence could have some steps with a chance setting to dictate whether it will sound or not. This can create interest and variety in melodies or beats.

1	D6 03 ---- V 0	1	D6 03 ---- C 25
5	D6 03 C 50 V 30	2	D6 03 ---- ----
9	D6 03 ---- V 55	3	D6 03 ---- C 85
13	D6 03 C 50 V 80	15	D6 03 ---- ----
16	D6 03 ---- V100	16	D6 03 ---- C 55

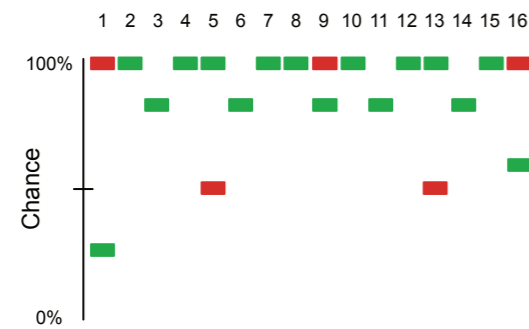

NOTES

7.14 Roll

FX Type Tag	Effect
R	Roll

FX Description

Repeat of the note applied using a step division. This can be straight repeats or evolving repeats depending on the roll type selected. The option for types are R, Rv, RV, Rn, RN, RR with a step divider range of 0 - 16.

Value Ranges

Pad Range
0 - 16 per Type
Pad 1 - 8 = R, Pads 9 - 16 = Rv, Pads 17 - 24 = RV,
Pads 25 - 32 = Rn, Pads 33 - 40 = RN, Pads 41 - 48 = RR.
Use Jog wheel for more precise and a wider selection.

Example

Rolls are extremely versatile and can be applied as volume or note pitch ramp up / down or just to randomise notes.

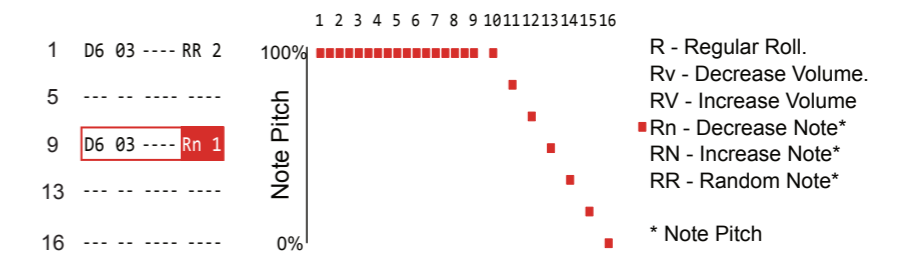
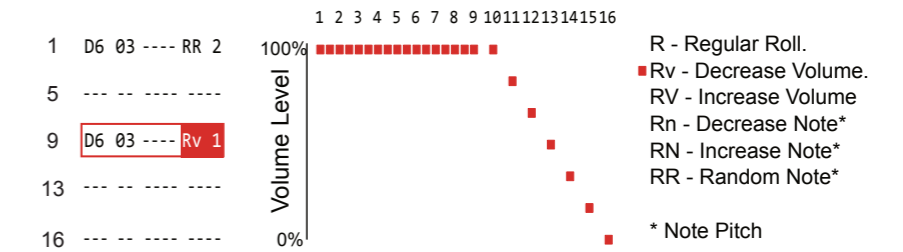

NOTES

7.15 Arpeggiator

FX Type Tag	Effect
A	Arp
FX Description	
Arpeggiator. This needs a note value and works in conjunction with the MIDI chord which must also be assigned to the other FX slot	
Value Range	Pad Range
See Below	Jog wheel gives precise and wider range of settings. Pads are more difficult when applying arp settings.

Set the FX1 slot to the Arp type. This can operate with a note melody: Up / Rising 'U' or Down / Falling 'D' or Random 'R'. The value is based on the tempo divider as a number e.g. 6 or multiplier e.g. .6 (dot 6).

Set the FX2 slot to MIDI Chord. This is an effect used with MIDI but also provides scale details for the Arp.

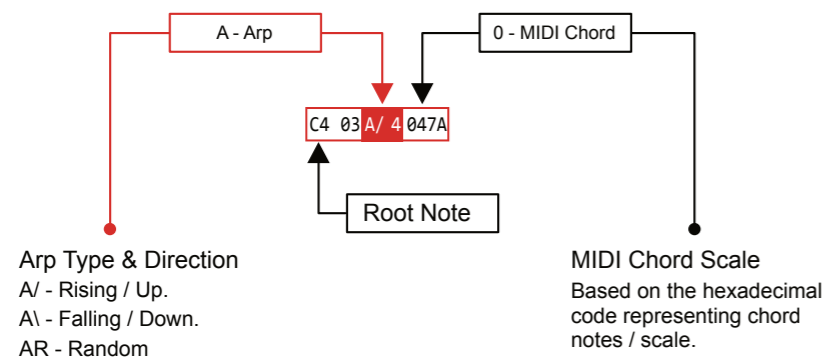

Example Tracker Chords

MIDI Chord Hex Code	Scale	A/ Rising Chord Example Root C	A\ Falling Chord Example Root C	AR Random Chord Example Root C
0 27	Sus2	C - D - G	G - D - C	Random order
0 57	Sus4	C - F - G	G - F - C	Random order
0 37	Min	C - D# - G	G - D# - C	Random order
0 47	Maj	C - E - G	G - E - C	Random order
0 5C	Open4	C - F - C	C - F - C	Random order
0 7C	Open5	C - G - C	C - G - C	Random order
0379	Min6	C - D# - G - A	A - G - D# - C	Random order
037A	Min7	C - D# - G - A#	A# - G - D# - C	Random order
0479	Maj6	C - E - G - A	A - G - E - C	Random order
047B	Maj7	C - E - G - B	B - G - E - C	Random order

NOTES

NOTES

Example

The Arp uses the Note as the root and the Arp effect sets the direction and timing. This needs a MIDI Chord also in the other FX slot to create the chord which will be arpeggiated. Setting the MIDI Chord to a value at '0' will play notes through a chromatic scale and is useful when setting up the Arp to get the direction and timing right before applying a specific scale.

Arp direction plus intervals can range through the dividers of 1, 2, 3, 4, 6, 8 and also the .1, .2, .3, .4, .6, .8 where a dot value indicates a multiplier.

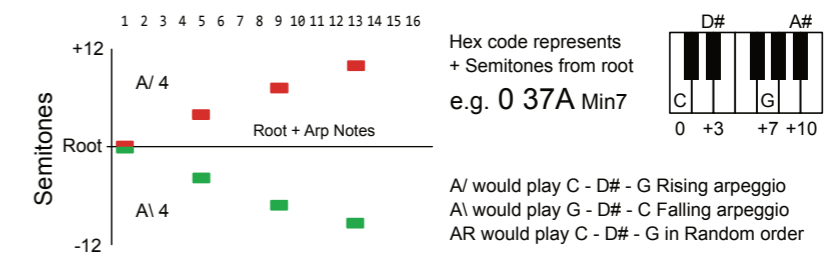

Tracker gives a series of scales in the MIDI Chord description. While these are useful examples they do not fully cover all chords. Other chords are also available, represented by the hexadecimal number in the MIDI Chord FX. Translating a chord to the hexadecimal code for the MIDI Chord assignment will allow a wider range to be used. Alternatively, and a more practical approach is trial and error and listening by ear of what sounds 'right' when selecting scales.

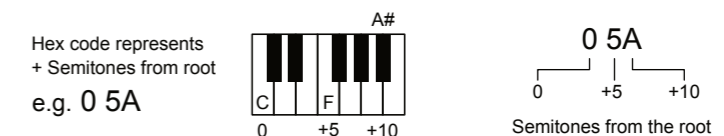

Hexadecimal to Decimal Converter

Hex	1	2	3	4	5	6	7	8	9	A	B	C	D	E	F
Dec	1	2	3	4	5	6	7	8	9	10	11	12	13	14	15

Other Examples

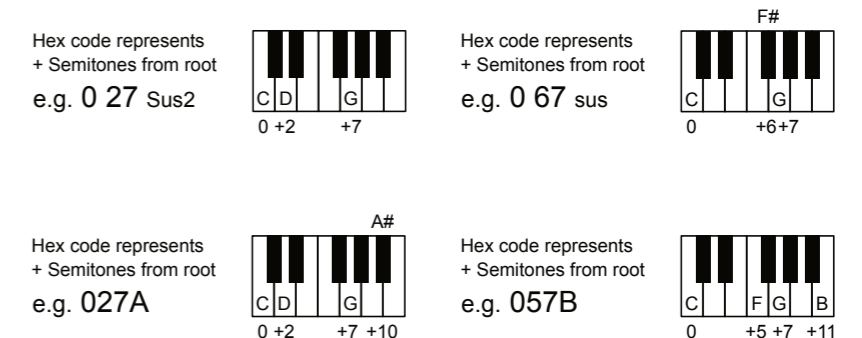

7.16 Random Note

FX Type Tag	Effect
n	Random Note

FX Description

Sets a range of notes from which a random selection will be made, for each play cycle of the pattern. Interval are based on the selected scale for the pads

Value Ranges	Pad Range
0 to +/-100	Pad 1 = +/- 0, Pad 13 = +/- 25, Pad 25 = +/- 51, Pad 48 = +/-100

Example

The randomisation is applied within a range set by the value. By default this is a +/- semitone range across a chromatic scale. However this is based on the config settings and can therefore be changed to another scale. Start with a small range setting to keep things musical and then apply a different setting to experiment with variations.

- 1 D6 03 ---- ----
- 5 D6 03 ---- n 3 Range is -3 to +3 deviation from root
- 9 D6 03 ---- ----
- 13 D6 03 ---- n 8 Range is -8 to +8 deviation from root
- 16 D6 03 ---- ----

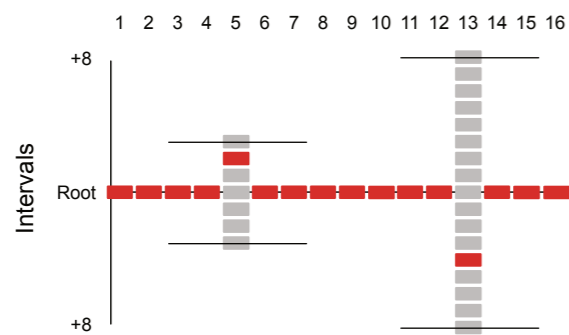

Notes 'n' will play randomly, through each pattern cycle. The selected range is set by the +/- value in the FX. This is applied with reference to the root note (Example D6) and determines the +/- offset from which the random note is selected.

NOTES

7.17 Random Instrument

FX Type Tag	Effect
i	Random Instrument

FX Description

Sets a range of instruments from which a random selection will be made, for each play cycle of the pattern. Intervals are based on the selected instrument and the range before and after in the project instrument list.

Value Ranges	Pad Range
0 to +/-47	Pad 1 = 0, Pad 13 = 12, Pad 25 = 24, Pad 37 = 36, Pad 48 = 47

Example

Try loading a cluster of samples into the instrument list. This will form the range to select from. The step instrument being the central instrument for the randomisation range. For example a variation of percussive hats or vocal stabs. The random pick will select from these.

- 1 D6 04 ---- i 2 Range is -2 to +2 deviation from current instrument
- 2 D6 04 ---- i 2 Range is -2 to +2 deviation from current instrument
- 3 D6 04 ---- i 2 Range is -2 to +2 deviation from current instrument
- 4 D6 04 ---- i 2 Range is -2 to +2 deviation from current instrument
- 5 D6 04 ---- i 2 Range is -2 to +2 deviation from current instrument

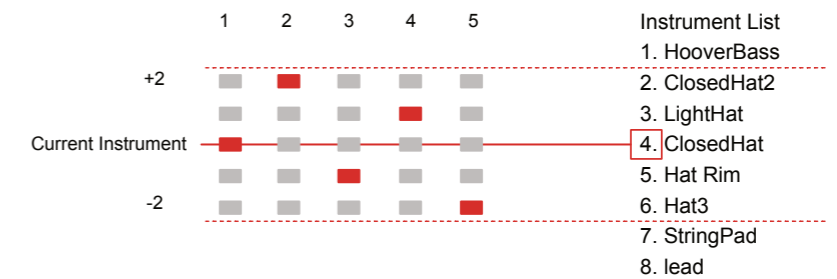

Instrument 'i' will play randomly, through each pattern cycle. The selected range is set by the +/- value in the FX. This is applied with reference to the current instrument (Example 4) and determines the +/- offset from which the random note is selected. +2 is the Hat3 and -2 is ClosedHat2. LightHat and Hat Rim are included in this range.

NOTES

7.18 Random FX

FX Type Tag	Effect
f	Random FX Value

FX Description

Selects a random FX value (not type) for the FX located in the other slot, same step. Plays a random selection each pattern cycle based on the set range.

Value Ranges	Pad Range
0 to +/-255	Jog wheel gives precise and wider range of settings. Pads are inconsistent for this selection.

Example

This feature can add a variation to a pattern. For example FX1 Random 20 applies to FX2 Gate length, which will be the value randomised. Gate length full range is 0-100%. FX2 Functions other than Gate Length can also be used.

```

1 D6 03 ---- V 0
5 D6 03 f 20 q 70 FX1 Randomises the value for FX2 (q - gate Length)
9 D6 03 ---- V 55 f 20 ▶ q 70
13 D6 03 C 50 V 80
16 D6 03 ---- V100
    
```

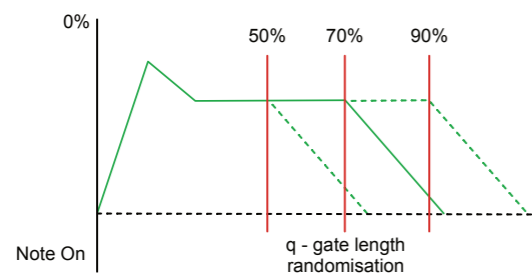

Gate Length
Gate length value is randomised by +/-20 applied by FX1 to the default of 70 in FX2. Therefore gate length value variation will be a value selected between 50 - 90 over each pattern cycle.

NOTES

7.19 Random Volume

FX Type Tag	Effect
v	Random Volume

FX Description

Creates a volume variation in each cycle of the pattern through randomisation of velocity. This is a value which is randomly selected from within a +/- range from the default volume level.

Value Ranges	Pad Range
0 to +/-100	Pad 1 = 0, Pad 13 = 25, Pad 25 = 51, Pad 37 = 76, Pad 48 = 100

Example

This is useful for creating accents and audible variations in volume level.

```

1 D6 03 ---- v 10 Range is -10 to +10 deviation from current default
5 ---- - - - - -
9 D6 03 ---- v 20 Range is -20 to +20 deviation from current default
13 ---- - - - - -
16 ---- - - - - -
    
```

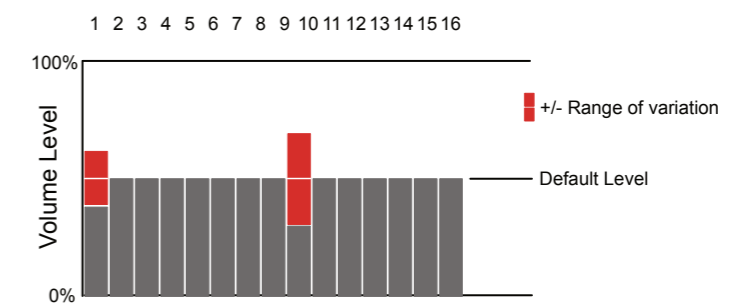

Playback will be at the default volume until a random volume step is triggered. A value somewhere in the range will then be applied.

NOTES

7.20 Reverse Sample

FX Type Tag	Effect
r	Reverses Sample Playback
FX Description	
Reverses the sample playback. Simply plays the sample forwards as normal or reverses its playback.	
Value Ranges	
<<< Or >>>	Pads 1 - 24 >>> Play Forward, Pads 25 - 48 <<< Reverse

Example
Reversing the sample playback is a simple application. The reverse will take place only on the step activated. It is also important in practical applications to know the sample length. If the 'tail' of a sample is long then reversing it may mean no sound is heard. Adjusting the 'end' parameter of the sample playback may also need to be changed.

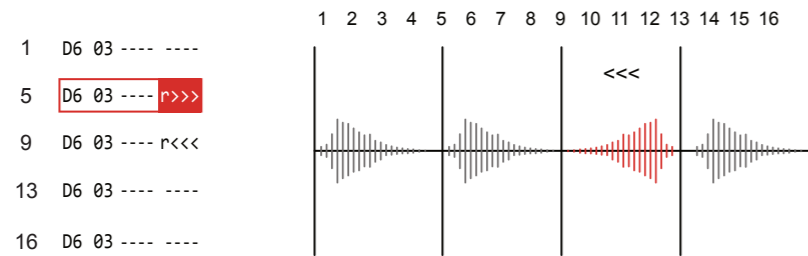

Normal Sample Direction.
Playback from 'Start' to 'End' parameters as set in the sample playback settings.

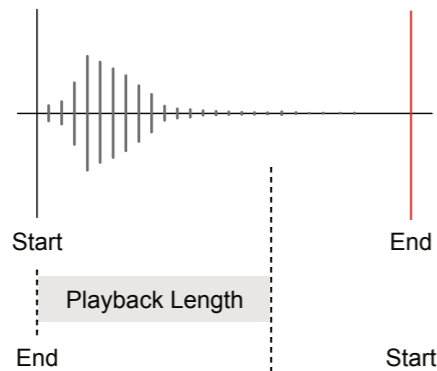

Reversed Sample Direction.
Playback from 'End' to 'Start' parameters as set in the sample playback settings. End may need to be adjusted to hear audio within the step duration.

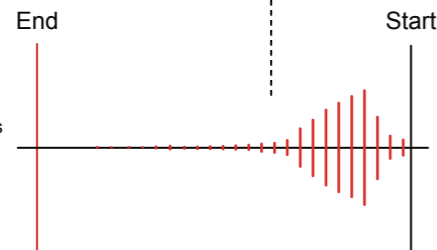

NOTES

7.21 Position

FX Type Tag	Effect
p	Position
FX Description	
Sample start position for playback is set. This is based on the playback type selected and better applied with one-shot samples, wavetables and granular. When using sliced samples the 'slice' FX is an alternative option.	
Value Ranges	
0 - 100%	Pad 1 = 0, Pad 13 = 12, Pad 25 = 24, Pad 37 = 36, Pad 48 = 47

Example
Try experimenting with different samples and start points. Use full samples (one-shots), wavetables and granular types for the full more pronounced effect. Happy accidents to find a 'sweet spot' in a sample are possible. Automate the variation using individual steps to create movement and interest.

- 1 F5 22 ---- p 5 Start position for sample used in instrument 22 only for this step
- 5 F5 22 ---- p 47 Start position for sample used in instrument 22 only for this step
- 9 F5 22 ---- p 65 Start position for sample used in instrument 22 only for this step
- 13 F5 22 ---- p 85 Start position for sample used in instrument 22 only for this step
- 16 F5 22 ---- ---- Position for steps in-between 'p' will operate at the normal start

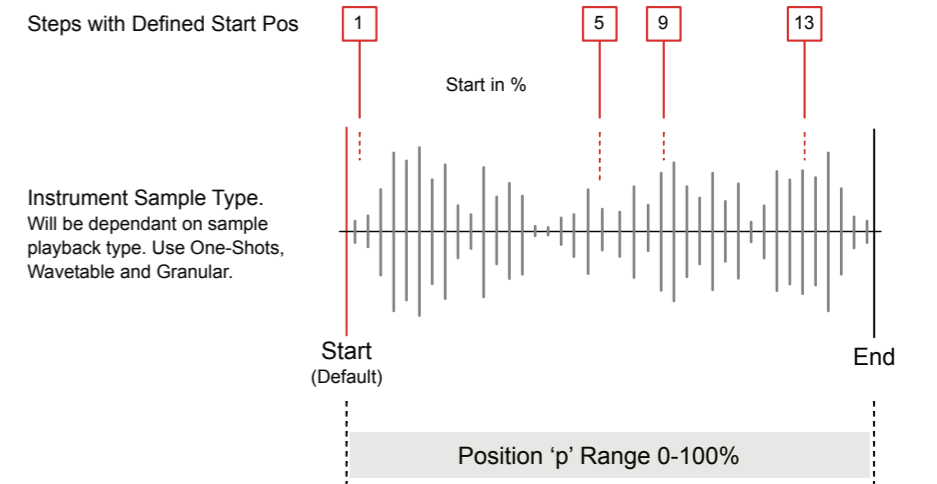

Instrument Sample Type.
Will be dependant on sample playback type. Use One-Shots, Wavetable and Granular.

NOTES

7.22 Slice

FX Type Tag	Effect
S	Slice Playback

FX Description

Plays a selected slice on the triggered step. While the FX range of steps is 1-48 it is typical to apply slices smaller groups e.g. 16 Steps. If so the selected step will wrap in the range.

Value Ranges

0 - 48
Pad Range: Pad 1 = 1, Pad 13 = 13 etc. However Pads will be based on available samples and the selection will wrap the range.

Example

The LFO is triggered by each step either using the rate from the step LFO pan or the default instrument parameter speed of no LFO FX is set. The LFO cycle is reset each trigger..

- 1 F5 16 ---- S 5 Slice 5 from beat sliced instrument 16 only for this step
- 5 F5 16 ---- S 18 Slice 2 (Wrapped 16+2) from beat sliced instrument 16.
- 9 F5 16 ---- S 12 Slice 12 from beat sliced instrument 16 only for this step
- 13 F5 16 ---- S 8 Slice 8 from beat sliced instrument 16 only for this step
- 16 F5 16 ---- ---- The last slice eg 16 is default if a slice selection is not defined.

Step	5	1	13	9
Slice Selected	18*	5	8	12
Slices Triggered	█	█	█	█
Beat Slices	1 2 3 4 5 6 8 10 11 12 15 15 16			

*18 = 16 Max Range + 2

Beat Sliced Sample.
For example 16 beat sliced 'hits' across a drum kit. The Steps 'S' FX will trigger the defined slice.

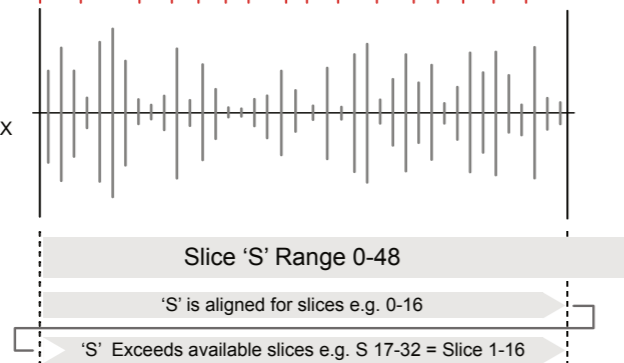

NOTES

7.23 Volume LFO

FX Type Tag	Effect
g	Volume LFO Rate

FX Description

Selects the rate for the instrument volume LFO. This setting is in increments with respect to project tempo. LFO is found in the instrument parameters P2/2.

Value Ranges

Various
Pad Range: Pad 1 = 128, Pad 13 = 16, Pad 30 = 1, Pad 34 = 1/2, Pad 46 = 1/8. Advise using Jog.

Example

The LFO is triggered by each step either using the rate from the step volume LFO or the default instrument parameter speed if no LFO FX is set. The LFO cycle is reset each trigger.

g Rates	128	96	64	48	32	24	16	12	8	6	4	3
	2	3/2	1	3/4	1/2	3/8	1/3	1/4	3/16 (3/16)	1/6	1/8	1/12 (1/12)

- 1 F5 16 ---- ---- Speed set in the Instrument Parameter Volume LFO will apply
- 5 F5 16 ---- g 48 Step will trigger the LFO Rate change
- 9 ---- ---- ---- Previous Step LFO Rate continues
- 13 ---- ---- ----

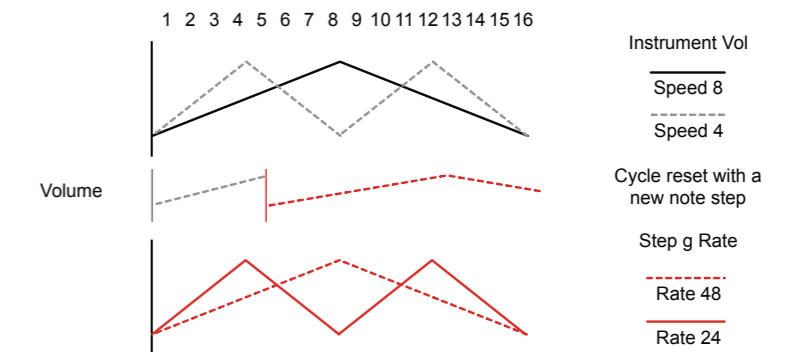
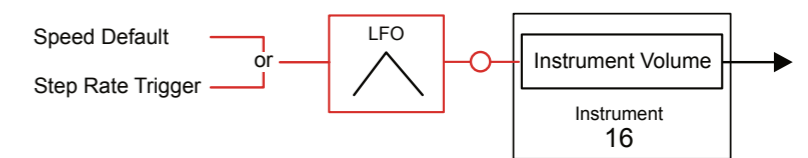

NOTES

7.24 Panning LFO

FX Type Tag	Effect
h	Panning LFO Rate

FX Description

Selects the rate for the instrument panning LFO. This setting is in increments with respect to project tempo. LFO is found in the instrument parameters P2/2.

Value Ranges

Various Pad Range
 Pad 1 = 128, Pad 13 = 16, Pad 30 = 1, Pad 34 = 1/2, Pad 46 = 1/8. Advise using Jog.

Example

The LFO is triggered by each step either using the rate from the step pan LFO or the default instrument parameter speed if no LFO FX is set. The LFO cycle is reset each trigger.

h Rates

128	96	64	48	32	24	16	12	8	6	4	3	2	3/2	1
3/4	1/2	3/8	1/3	1/4	3/16 (3/16)	1/6	1/8	1/12 (1/12)	1/16 (1/16)	1/24 (1/24)	1/32 (1/32)	1/48 (1/48)	1/64 (1/64)	

- 1 F5 22 ---- Speed set in the Instrument Parameter Panning LFO will apply
- 5 F5 22 ---- h 16 Step will trigger the LFO Rate change
- 9 ---- Previous Step LFO Rate continues
- 13 ----

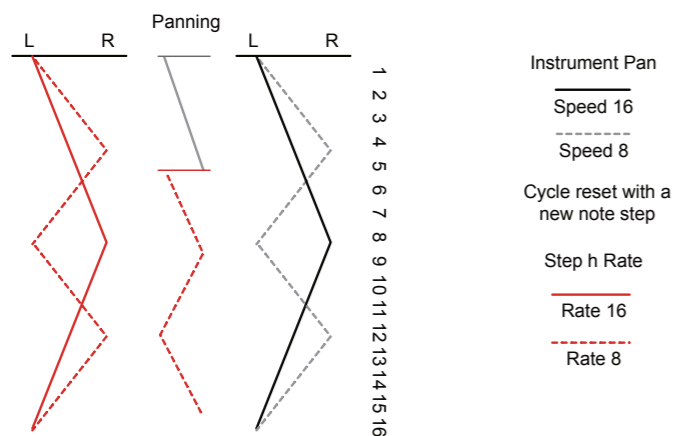
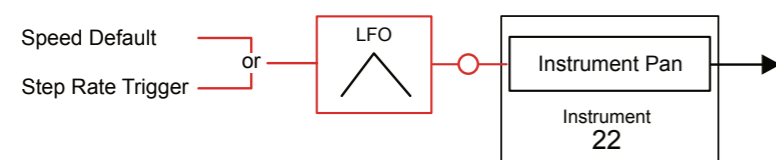

NOTES

7.25 Filter LFO

FX Type Tag	Effect
j	Filter Cutoff LFO Rate

FX Description

Selects the rate for the instrument filter cutoff LFO. This setting in increments with respect to project tempo. LFO is found in the instrument parameters P2/2. A filter type will need to be set which will effect the behaviour of the LFO.

Value Ranges

Various Pad Range
 Pad 1 = 128, Pad 13 = 16, Pad 30 = 1, Pad 34 = 1/2, Pad 46 = 1/8

Example

The LFO is triggered by each step either using the rate for the filter step LFO or the default instrument parameter speed of no LFO FX is set. The LFO cycle is reset each trigger. Higher rates 128-32 good for sweeps and mid range 4-1/3 good for dubstep style wobble.

j Rates

128	96	64	48	32	24	16	12	8	6	4	3	2	3/2	1
3/4	1/2	3/8	1/3	1/4	3/16 (3/16)	1/6	1/8	1/12 (1/12)	1/16 (1/16)	1/24 (1/24)	1/32 (1/32)	1/48 (1/48)	1/64 (1/64)	

- 1 F5 24 ---- j 2 Speed set in the Instrument Parameter LFO will apply
- 5 F5 24 ---- !OFF OFF may be used to avoid filter state cutting out all audio
- 9 F5 24 ---- Plays at default filter setting
- 13 ----

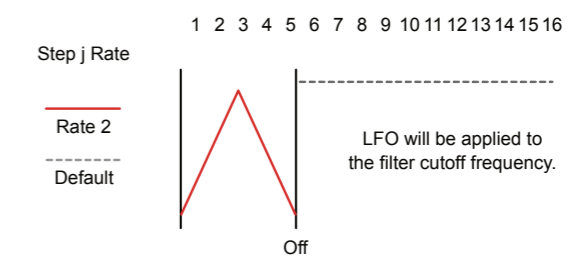
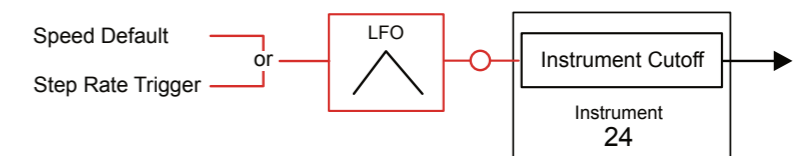

The impact of the LFO will depend on the type of filter selected and the settings in the filter LFO and settings in the instrument parameters.

NOTES

7.26 Position LFO

FX Type Tag	Effect
k	Position LFO Rate

FX Description

Selects the rate for the instrument wavetable / granular sample position LFO. This setting is in increments with respect to project tempo. LFO is found in the instrument parameters P2/2.

Value Ranges

Various Pad Range
 Pad 1 = 128, Pad 13 = 16, Pad 30 = 1, Pad 34 = 1/2, Pad 46 = 1/8. Advise using Jog.

Example

The LFO will adjust the position in the wavetable or granular sample. One of these play modes must be set to apply a position modulation from the LFO. The step then can vary the speed of the LFO per step.

h Rates

128	96	64	48	32	24	16	12	8	6	4	3	2	3/2	1
3/4	1/2	3/8	1/3	1/4	316 (3/16)	1/6	1/8	1/12 (1/12)	1/16 (1/16)	1/24 (1/24)	1/32 (1/32)	1/48 (1/48)	1/64 (1/64)	

- 1 F5 22 ---- Speed set in the Instrument Parameter Panning LFO will apply
- 5 F5 22 ---- **k 12** Step will trigger the LFO Rate change
- 9 ---- Previous Step LFO Rate continues
- 13 ----

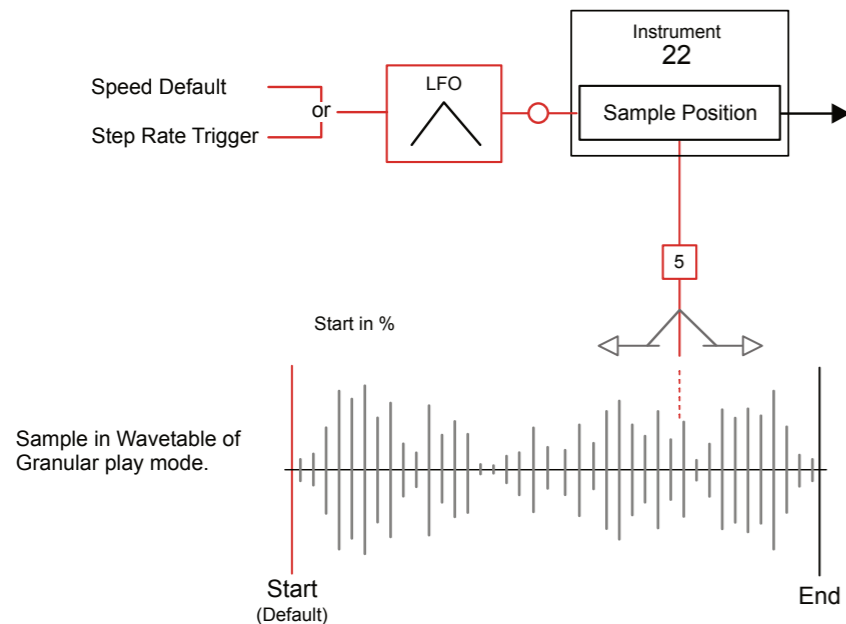

NOTES

7.27 Finetune LFO

FX Type Tag	Effect
l	Finetune LFO Rate

FX Description

Selects the rate for the instrument finetuning LFO. This setting is in increments with respect to project tempo. LFO is found in the instrument parameters P2/2.

Value Ranges

Various Pad Range
 Pad 1 = 128, Pad 13 = 16, Pad 30 = 1, Pad 34 = 1/2, Pad 46 = 1/8

Example

The LFO is triggered by each step applied. Slower rates are good to introduce an evolving slight pitch variation.

l Rates

128	96	64	48	32	24	16	12	8	6	4	3	2	3/2	1
3/4	1/2	3/8	1/3	1/4	316 (3/16)	1/6	1/8	1/12 (1/12)	1/16 (1/16)	1/24 (1/24)	1/32 (1/32)	1/48 (1/48)	1/64 (1/64)	

- 1 F5 24 ---- **l 48** Speed of LFO for the step.
- 5 ----
- 9 F5 24 ---- Triggers note at correct pitch
- 13 ----

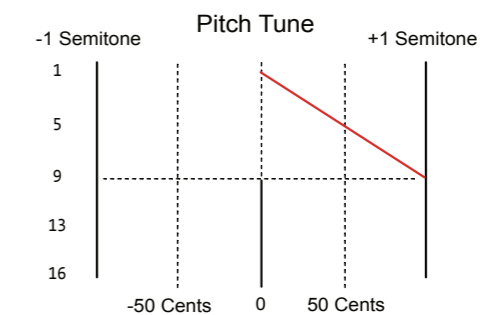
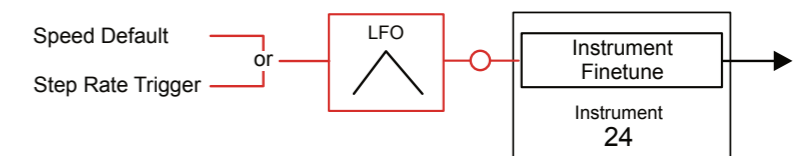

NOTES

7.28 Overdrive

FX Type Tag	Effect
D	Overdrive amount

FX Description

Selects the amount of overdrive applied for the duration of the specific step. Overdrive is found in the instrument parameters P1/2 - Effects.

Value Ranges

0-100% Pad Range
Pad 1 = 0%, Pad 13 = 25, Pad 25 = 51, Pad 37 = 76, Pad 48 = 100%.

Example

Can be used simply to add overdrive for the specific instrument and create variety across a pattern.

- 1 F5 16 ---- D 20
- 5 F5 16 ---- D 17 Variation of overdrive instrument effect
- 9 F5 16 ---- D 10
- 13 F5 16 ---- D 5
- 16 F5 16 ---- ----

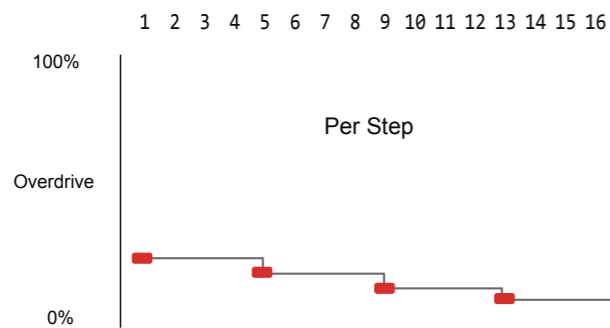

Take care when working with overdrive, especially with headphones. This can become loud. Start with smaller settings and expand as required.

NOTES

7.29 Low Pass Cutoff

FX Type Tag	Effect
L	Low Pass Filter

FX Description

Adjust the instrument cutoff frequency of the low pass filter. The instrument filter is found in the instrument parameters P2/2 but can be disabled and this effect will still operate.

Value Ranges

0-100% Pad Range
Pad 1 = 0%, Pad 13 = 25, Pad 25 = 51, Pad 37 = 76, Pad 48 = 100%.

Example

The cutoff frequency can be triggered by each step applied. This allows sweeps using only FX steps with multiple steps ramping the value or glitchy sequenced filter effects. 100% plays the sound as normal, all frequencies present, while 0% will totally cutoff all frequencies.

- 1 F5 16 ---- ---- Note and Instrument triggered with no filtering
- 5 ---- ---- L 80
- 9 ---- ---- L 60
- 13 ---- ---- L 40
- 16 ---- ---- L 0 Sample triggered at step 1 will be fully filtered

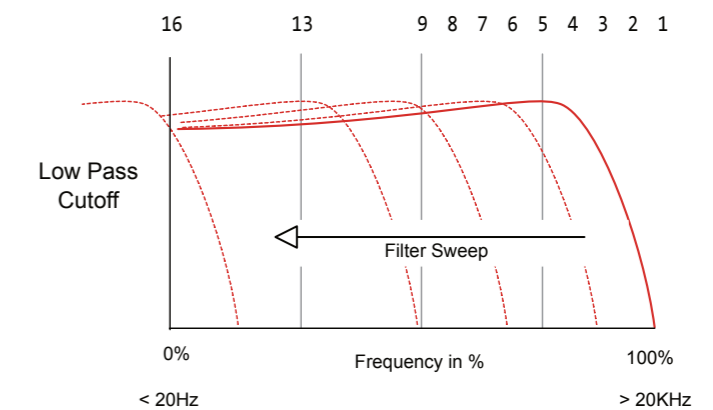

NOTES

7.30 Band Pass Cutoff

FX Type Tag	Effect
B	Band Pass Filter

FX Description

Adjust the instrument cutoff frequency of the band pass filter. The instrument filter is found in the instrument parameters P2/2 but can be disabled and this effect will still operate.

Value Ranges

0-100% Pad Range
 Pad 1 = 0%, Pad 13 = 25, Pad 25 = 51, Pad 37 = 76, Pad 48 = 100%.

Example

The cutoff frequency can be triggered by each step applied. This allows sweeps using only FX steps with multiple steps ramping the value or glitchy sequenced filter effects.

- 1 F5 16 ---- B 0 Note and Instrument triggered
- 5 ---- B 25
- 9 ---- B 50
- 13 ---- B 75 Band sweeps through the frequencies
- 16 ---- B100

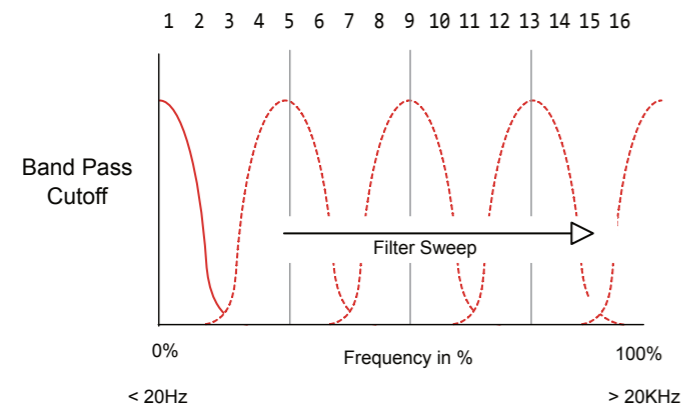

NOTES

7.31 High Pass Cutoff

FX Type Tag	Effect
H	High Pass Filter

FX Description

Adjust the instrument cutoff frequency of the high pass filter. The instrument filter is found in the instrument parameters P2/2 but can be disabled and this effect will still operate.

Value Ranges

0-100% Pad Range
 Pad 1 = 0%, Pad 13 = 25, Pad 25 = 51, Pad 37 = 76, Pad 48 = 100%.

Example

The cutoff frequency can be triggered by each step applied. This allows sweeps using only FX steps with multiple steps ramping the value or glitchy sequenced filter effects. 0% plays the sound as normal, all frequencies present, while 100% will almost cutoff all frequencies.

- 1 F5 16 ---- ---- Note and Instrument triggered with no filtering
- 5 ---- H 25
- 9 ---- H 50
- 13 ---- H 75
- 16 ---- H100 Sample triggered at step 1 will be fully filtered

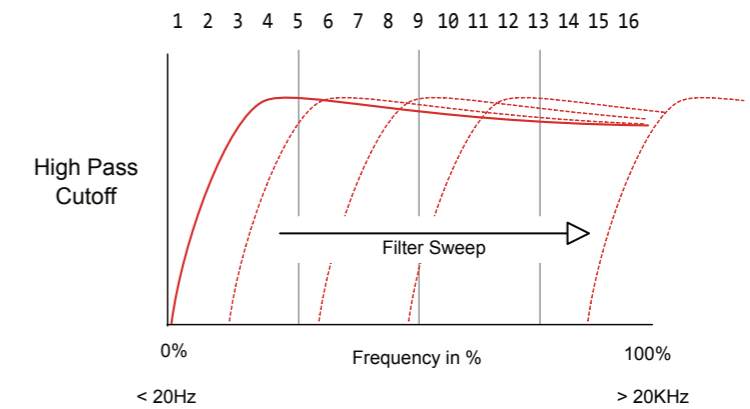

NOTES

7.32 Delay

FX Type Tag	Effect
s	Delay Effect Send

FX Description

Sets the amount of the audio signal to send to the delay effect. The delay effect settings are found in the Master section. Type of delay, feedback etc are adjusted generically, for the project in master settings.

Value Ranges

0-100% Pad Range
Pad 1 = 0%, Pad 13 = 25, Pad 25 = 51, Pad 37 = 76, Pad 48 = 100%.

Example

The effect is applied on the step triggered and the delay will be heard and extended through the pattern. The sound will depend on the master effect settings too. This step effect only controls the audio amount sent to the delay.

```

1  F5 18 ---- B 0
5  F5 18 ---- s 75  Delay send amount initiated with the note
9  ----
13 F5 18 ----
16 ----  Delay will have an audio tail beyond its step
    
```

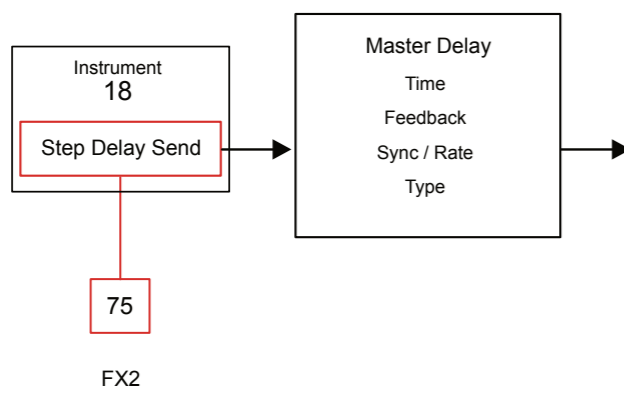

NOTES

7.33 Reverb

FX Type Tag	Effect
t	Reverb Effect Send

FX Description

Sets the amount of the audio signal to send to the reverb effect. The reverb effect settings are found in the Master section. Reverb size, damping, pre-delay etc are adjusted generically, for the project in the master settings.

Value Ranges

0-100% Pad Range
Pad 1 = 0%, Pad 13 = 25, Pad 25 = 51, Pad 37 = 76, Pad 48 = 100%.

Example

The effect is applied on the step triggered and the reverb will be heard and extended through the pattern. The sound will depend on the master effect settings too. This step effect only controls the audio amount sent to the reverb.

```

1  F5 16 ----
5  F5 16 ---- t 50  Reverb send amount initiated with the note
9  ----
13 F5 16 ----
16 ----  Reverb will have an audio tail beyond its step
    
```

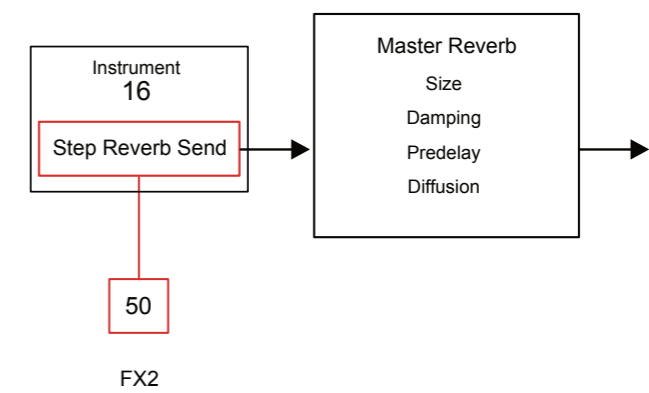

NOTES

7.34 Bit Depth

FX Type Tag	Effect
E	Bit Depth

FX Description

Sets the bit depth for the step. This can range from 4 Bits to 16 Bits Normal maximum setting). Lower rates create a more LoFi grainy sound texture.

Value Ranges	Pad Range
4-16 Bits	Pad 1 = 4 Bits, Pad 13 = 7, Pad 25 = 10, Pad 48 = 16 Bits

Example

The effect is applied on the step triggered and will apply a LoFi sound. This is great to create chip tune and classic video game like sounds and LoFi and glitchy emulations.

1	F5 18 ---- E 4	Set to 4 Bit reduction to create a noisy texture.
5	F5 18 ---- ----	
9	-----	
13	F5 18 ---- E 12	
16	-----	

NOTES

7.35 Tune

FX Type Tag	Effect
U	Tuning Adjustments

FX Description

Adjusts the step tuning across a 4 Octave range. Introduce a variation from the step note between -24 Semitones to +24 Semitones.

Value Ranges	Pad Range
-24 to +24 Semitones	Pad 1 = -24 Semitones, Pad 13 = -12 Semitones, Pad 25 = 0, Pad 36 = 12, Pad 48 = +24 Semitones.

Example

The tuning parameter transposes the current step from it's actual 'note' setting.

1	C4 09 ---- ----	Note C4 played with no transposition
5	C4 09 ---- U 12	Note C4 Transposed up 12 Semitones
9	C4 09 ---- U 5	Note C4 Transposed up 5 Semitones
13	C4 09 ---- U 0	Note C4 played with no transposition
16	-----	

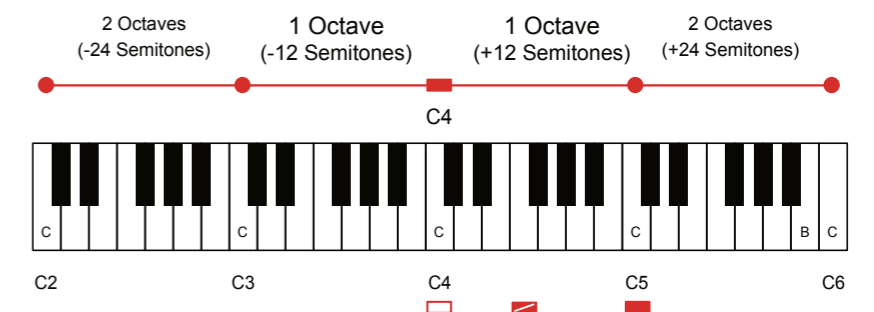
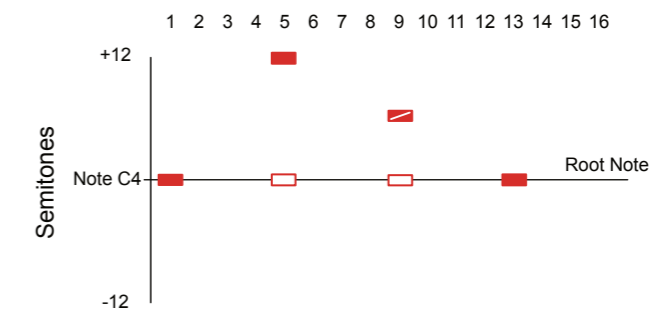

NOTES

7.36 Slide Up

FX Type Tag	Effect
F	Slide Up - Pitch

FX Description

Creates a pitch slide up from the current note as the starting reference. The intervals are in 1/16th Semitone mapped across the 0-255 range.

Value Ranges	Pad Range
0-255	Pad 1 = 0, Pad 4 = 16, Pad 7 = 32, Pad 25 = 130, Pad 36 = 189, Pad 48 = 255. Use Jog for more precise changes.

Example

While the glide effect operates on a time based pitch change and is referenced from the previous step, the slide function operates using semitone increments to control pitch from the current step note value. Values in denominations of 16 represent semitones.

- 1 C5 18 ---- Triggers a C5 Note
- 5 C6 18 ---- F 16 Triggers a C6 Note which slides up 1 Semitone i.e. 16/16
- 9 ----
- 13 C6 18 ---- F 32 Triggers a C6 Note which slides up 2 Semitones i.e. 32/16
- 16 ----

Step 1 Trigger C5

Step 5 Trigger C6  Value 16 = 1 Semitone

Step 13 Trigger C6  Value 32 = 2 Semitones

Slides the pitch from the current note up in 1/16th of a semitone iterations. A value of 16 will slide 1 Semitone.

Slide Range Converter (Estimated)

Value	0	16	32	64	80	112	128	192	224	255
Semitones	0	1	2	4	5	7	8	12	14	16

NOTES

7.37 Slide Down

FX Type Tag	Effect
J	Slide Down - Pitch

FX Description

Creates a pitch slide down from the current note as the starting reference. The intervals are in 1/16th Semitone mapped across the 0-255 range.

Value Ranges	Pad Range
0-255	Pad 1 = 0, Pad 4 = 16, Pad 7 = 32, Pad 25 = 130, Pad 36 = 189, Pad 48 = 255. Use Jog for more precise changes.

Example

While the glide effect operates on a time based pitch change and is referenced from the previous step, the slide function operates using semitone increments to control pitch from the current step note value. Values in denominations of 16 represent semitones.

- 1 C5 18 ---- Triggers a C5 Note
- 5 C6 18 ---- J 80 Triggers a C6 Note which slides down 5 Semitones i.e. 80/16
- 9 ----
- 13 C6 18 ---- F112 Triggers a C6 Note which slides down 7 Semitones i.e. 112/16
- 16 ----

Step 1 Trigger C5

Step 5 Trigger C6  Value 80 = 5 Semitone

Step 13 Trigger C6  Value 112 = 7 Semitones

Slides the pitch from the current note up in 1/16th of a semitone iterations. A value of 16 will slide 1 Semitone.

Slide Range Converter (Estimated)

Value	0	16	32	64	80	112	128	192	224	255
Semitones	0	1	2	4	5	7	8	12	14	16

NOTES

7.38 MIDI Messages

FX Type Tag	Effect
a - f	MIDI CC A-F Messages

FX Description

Issues MIDI output messages. These can be CC (Control Change), PC (Program Change), Polyphonic Aftertouch or Channel Aftertouch selectable in the Instrument Parameters. Requires a MIDI instrument set with the channel.

Value Ranges

0-127
Pad Range: Pad 1 = 0, Pad 13 = 32, Pad 25 = 64, Pad 48 = 127. Use Jog for more precise changes.

Example

While the glide effect operates on a time based pitch change and is referenced from the previous step, the slide function operates using semitone increments to control pitch from the current step note value. Values in denominations of 16 represent semitones.

- 1 C5 18 ----
- 5 **C6 M01 ---- a 24**
- 9 ----
- 13 C6 18 ---- F 32
- 16 ----

Sends a CC Value of 24 to MIDI Channel 1. Parameter to control is set in 'Instrument Parameters'

Mod Wheel.
The destination parameter is defined in the instrument parameter settings when a MIDI Instrument is used.

0 Bank
1 ModWh
2 Brth
3
4 Foot
5 Glide
6 Data
7 ChVol
8 Balnc
9
10 Pan
11 Exp
12
13
CC A
1

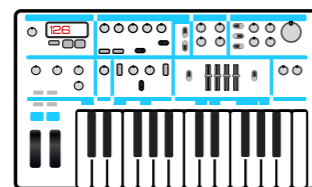

MIDI Message to control external device.

FX1 or FX2 + Value
a 24 CC Value to send

Range 0 - 127

Instrument
M01 MIDI Channel 1

Max 16 MIDI Instruments, each can host up to 6 CC Values

NOTES

NOTES

7.39 MIDI Chords

FX Type Tag	Effect
0	MIDI Chords Out

FX Description

Sends MIDI Chords out which are a combination of notes based on the numerical (Hex) value of the step FX. MID Chord is also used in conjunction with Arp step FX.

Value Ranges

Various
Pad Range: Pad 1 = 0, Pad 4 = 16, Pad 7 = 32, Pad 25 = 130, Pad 36 = 189, Pad 48 = 255. Use Jog for more precise changes.

Example

The chord is derived from the hexadecimal value applied in the MIDI Chord step and selected from a defined library of chords. The first '0' represents the MIDI Chord effect other digits the chord notes, offset from the root note.

- 1 **C5 18 ---- 0 47** Triggers a Major Chord: C5 + 4 Semitones + 7 Semitones.
- 5 C6 18 ---- Triggers a C6 Note.
- 9 ---- Hex code represents + Semitones from root
- 13 C6 18 ---- F112 e.g. **0 47** Maj
- 16 ----

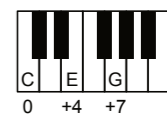

Hexadecimal to Decimal Converter

Hex	1	2	3	4	5	6	7	8	9	A	B	C	D	E	F
Dec	1	2	3	4	5	6	7	8	9	10	11	12	13	14	15

Tracker Chords (Root C Examples)

MIDI Chord Hex Code	Scale	Chord Example from Root C	MIDI Chord Hex Code	Scale	Chord Example from Root C
0 27	Sus2	C - D - G	0368	Dim7	C - D# - F# - G#
0 28	Sus2 #5	C - D - G#	036A	Half Dim	C - D# - F# - A#
0 36	DimTriad	C - D# - F#	0378	Min b6	C - D# - G - G#
0 37	Min	C - D# - G	0379	Min6	C - D# - G - A
0 47	Maj	C - E - G	037A	Min7	C - D# - G - A#
0 48	AugTriad	C - E - G#	037B	MinMaj7	C - D# - G - B
0 57	Sus4	C - F - G	0479	Maj6	C - E - G - A
0 5A	Stack4	C - F - A#	047A	Dom7	C - E - G - A#
0 5C	Open4	C - F - C	047B	Maj7	C - E - G - B
0 67	Sus #4	C - F# - G	0489	Aug Add6	C - E - G# - A
0 7C	Open5	C - G - C	048A	Aug b7	C - E - G# - A#
0 7E	Stack5	C - G - D	048B	Aug Maj7	C - E - G# - B
0279	Sus2Add6	C - D - G - A	057A	Sus b7	C - F - G - A#
027A	Sus2 b7	C - D - G - A#	057B	Su4Maj7	C - F - G - B
027B	Sus2Maj7	C - E - G - B			

Audio

Audio is the central element in Tracker and at the heart of almost everything. The end to end process of Sampling - Editing - Performing carries many sub topics that involve audio. Patterns are made with instruments and notes that trigger sounds. The process starts with the procuring, capturing or recording of audio. Multiple audio sources are available from which to sample. It is possible to connect external line level gear, a microphone and even record from the internal radio. In addition the ability to render internal audio is also a useful feature. Tracker works with PCM WAV files and converts to automatically to use 44.1kHz, 16bit mono. Samples in the pool are interpolated. Anti-aliasing option is available in the 'Config' menu. Many options exist to render and export either parts of patterns, full songs or track stems. Be aware rendering may take some time as it sequentially renders to audio almost real time. A toolkit of destructive

editing features helps to prepare audio for use in instruments and patterns and for further integration with other features such as the play modes and routing through effects. Each Projects can hold up to 133 seconds of mono audio samples although the available memory can be increased by using lower quality audio. Of course Tracker already is supplied out of the box with a number of samples and instruments pre-loaded to the supplied SD Card. These are great to get things started and additional samples can be added and imported. It is important to state that adherence to copyright laws and original material ownership should be respected when recording and sampling audio. Take care to operate within any relevant laws especially if considering to commercially release a track. So this section will cover the recording and editing of audio samples within the sample recorder and sample editor pages as well as the general render and export file page options.

8.1 Master Pages - Audio Control

Audio is controlled in the Master pages of which 3 are available. This is where the Tracker mixer is found to control the audio levels and also the master effects. This section will concentrate on the audio level and routing controls. The Master effects are covered in another section.

Master - Page 1

The Master mix is the first page in the master pages and contains the main output level as well as a series of effects and access to the master reverb and delay effects. Rendered audio exports of the 'master' i.e. all tracks, uses the volume level and functions in Master page 1.

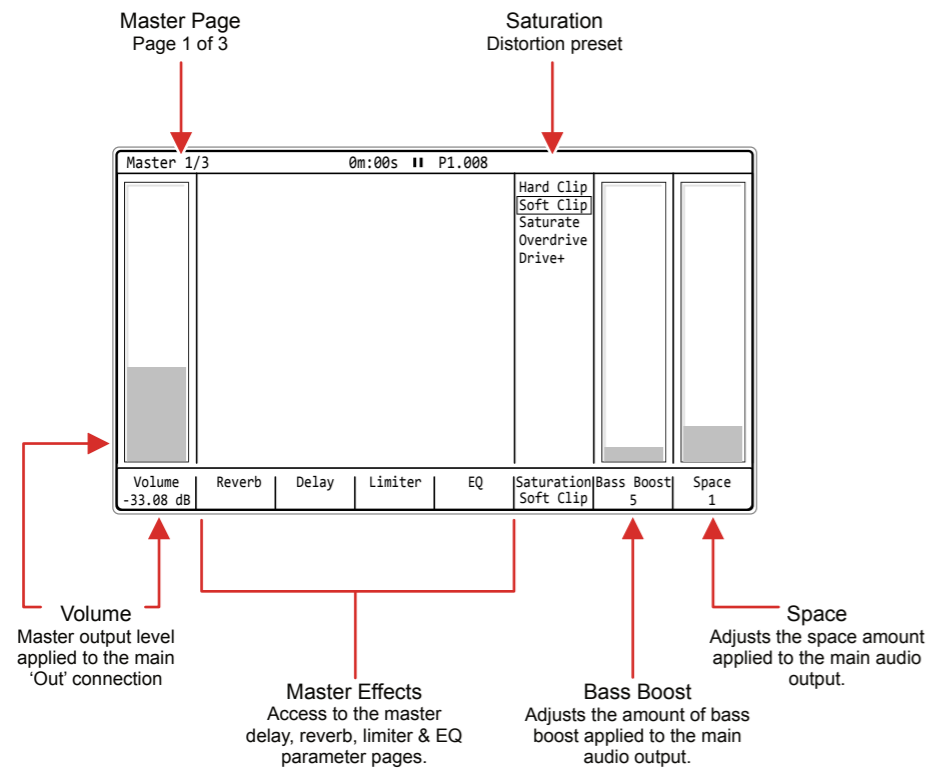

Function	Command
Navigate Options	Press [Left] or [Right]
Edit Parameter	With option selected, Turn (Jog) or Press [Up] or [Down]
Select Effect Page	Press Track Screen Button 2 [Reverb], 3 [Delay], 5 [Limiter] or 6 [EQ].
Quick Level Adjust	Hold [Master] + Turn (Jog)

NOTES

NOTES

Track Mixer - Page 2

The Master page controls the track volume levels. Each of the 8 tracks is displayed with the real time level bar graph and the current setting in the bar graph and the value shown in the track label. Tracks rendered as individual stems will use the levels set for tracks. Note that track names can be edited in this page by pressing [Rec].

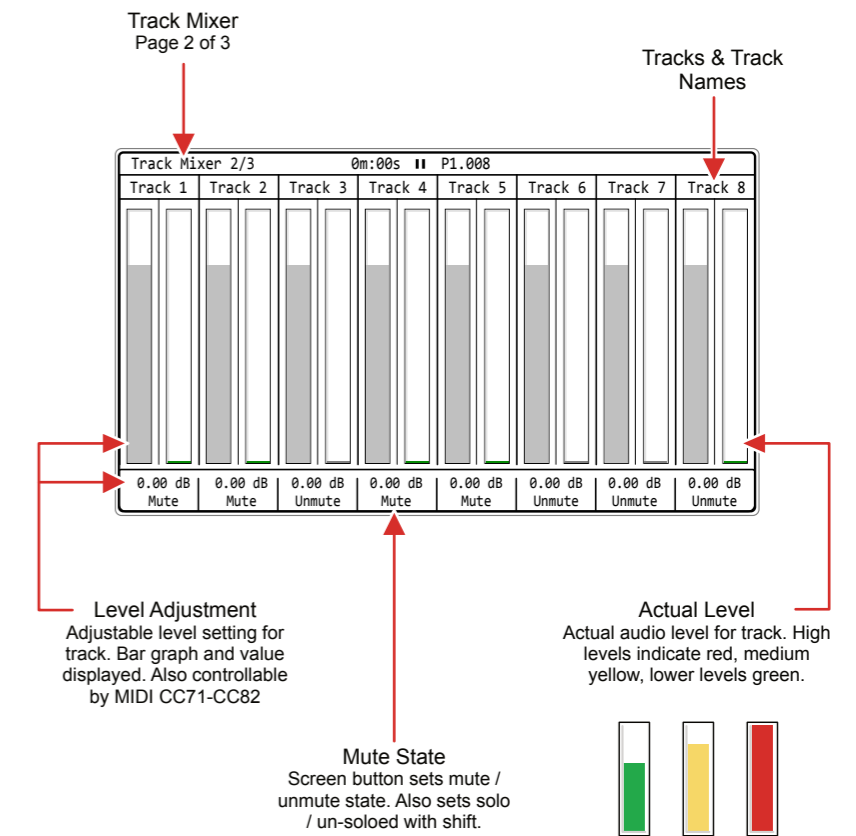

Function	Command
Adjust Track Level	Hold Track Screen Button 1-8 + Turn (Jog) or Press [Up] or [Down]
Mute Track	Press Track Screen Button 1-8 to toggle Mute / Unmute
Unmute Track	Press Track Screen Button 1-8 to toggle Mute / Unmute
Solo Track	Hold [Shift] + Press Track Screen Button 1-8 to toggle Solo on/off
Edit Track Names	Press [Rec], Edit Mode. Press Track Screen Button 1-8 for track to rename.

Mute Button Behaviour.

In the master section mute is applied when the button is released after being pressed. This is different to muting in the Pattern section where mutes are applied immediately that the button is pressed.

Global Mixer - Page 3

The Global Mixer is the third page in the master pages and contains the line in level and line in delay / reverb send levels for the pass through. Also the overall master delay, reverb level and dry / wet mix. These can all be muted and all soloed, with the exception of the line delay and reverb which can only be muted / unmuted.

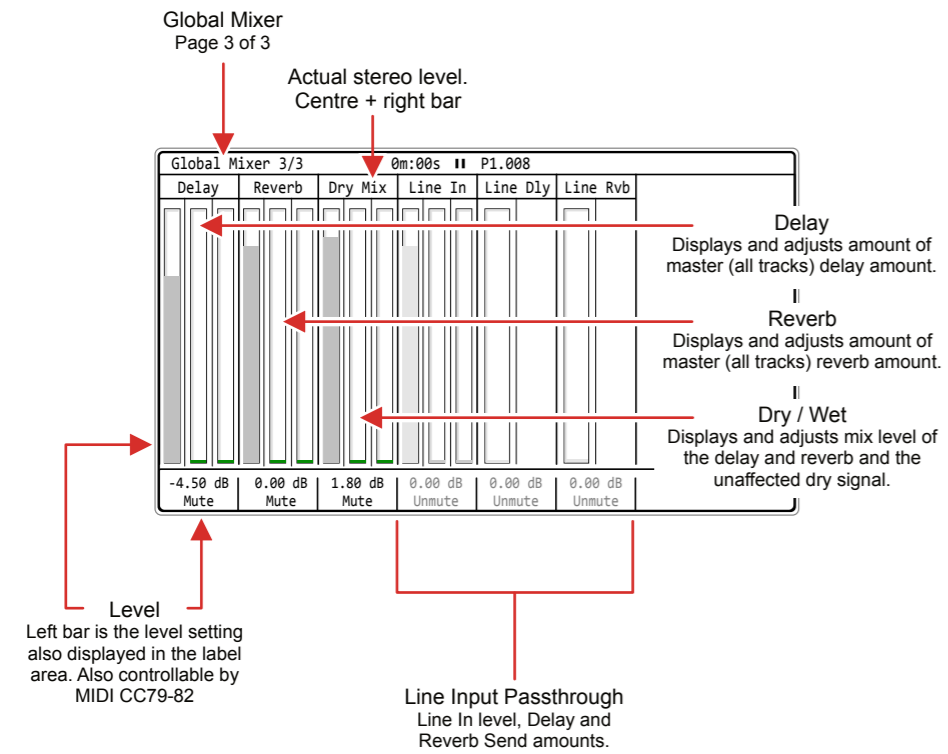

NOTES

Function	Command
Adjust Level	Hold Option Screen Button 1-6 + Turn (Jog) or Press [Up] or [Down]
Mute Option	Press Option Screen Button 1-6 to toggle Mute / Unmute
Unmute Track	Press Option Screen Button 1-6 to toggle Mute / Unmute
Solo Option	Hold [Shift] + Press Option Screen Button 1-4 to toggle Solo on/off

Mute Button Behaviour.

In the master section mute is applied when the button is released after being pressed. This is different to muting in the Pattern section where mutes are applied immediately that the button is pressed.

NOTES

8.2 Audio Sources

There are a number of sources where Tracker can access audio. Some of which are 'live' sources and can easily be sampled. Others manually managed or rendered within the device.

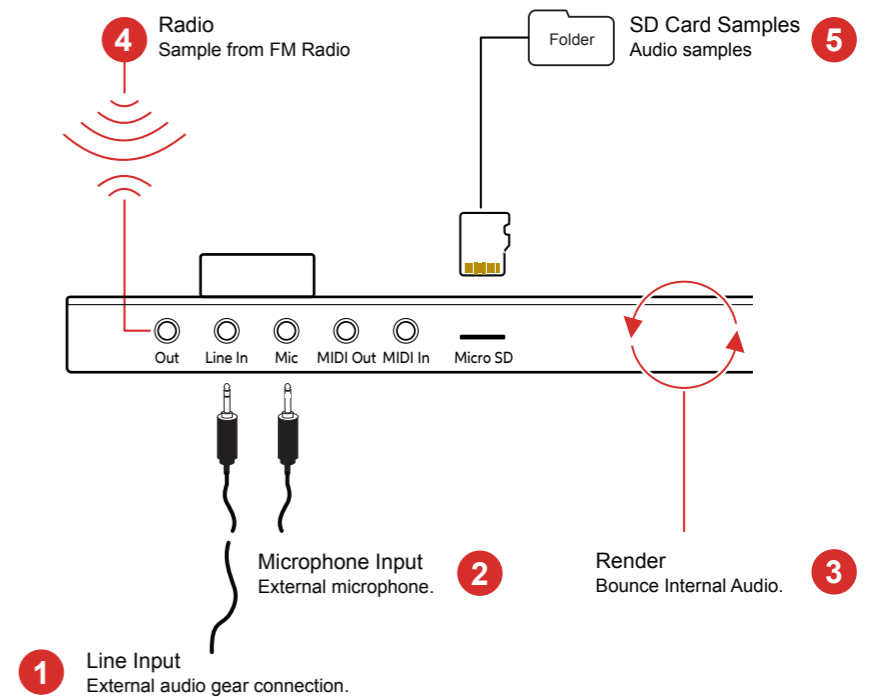

- 1** Line Input
External audio gear connection.
3.5mm Input jack which allows Stereo (TRS) and Mono (TS) audio inputs. Stereo signals are converted to mono when recorded and the L & R channels can also be selected individually.
- 2** Mic Input
3.5mm Microphone Input jack which allows Stereo (TRS) and Mono (TS) audio inputs. Stereo signals are converted to mono when recorded. This does not supply 48V phantom power so typically use a dynamic microphone.
- 3** Render
A feature which is available with the internal functions is render. This bounces or exports an audio file based on the selected pattern / tracks which can then be made immediately available as a sample or to use from the instrument list.
- 4** FM Radio
Tracker has an inbuilt FM radio. Reception can be improved by connecting an aerial or cable into the output connection. The reception region can be set in the radio function. Radio can be recorded and sampled directly within Tracker.
- 5** SD Card
Audio samples are stored on the SD Card. These can be sampled and stored from within Tracker but also can be manually transferred onto the SD card from and external source using a PC or Mac.

Tracker is supplied with a 3.5mm Stereo Male Jack to 2 x 6.3mm Mono Female Socket adapter to allow interfacing with external gear and using the more common 6.3mm mono cables.

8.3 Audio Inputs

Tracker has two audio inputs that provide a source to sampling and recording from external sources. The physical inputs are located on the rear of the device and provide access for microphone and line in either using TRS Stereo or TS Mono jacks or the supplied 3.5mm to 2 x 6.3mm adapter.

Line Input

The input can be selected between Left, Right or Stereo. While these are selectable options Tracker records in mono. Tracker can record audio or play a pattern audio but not both together at the same time. Playing patterns will therefore output MIDI but not audio if sample recording is in progress.

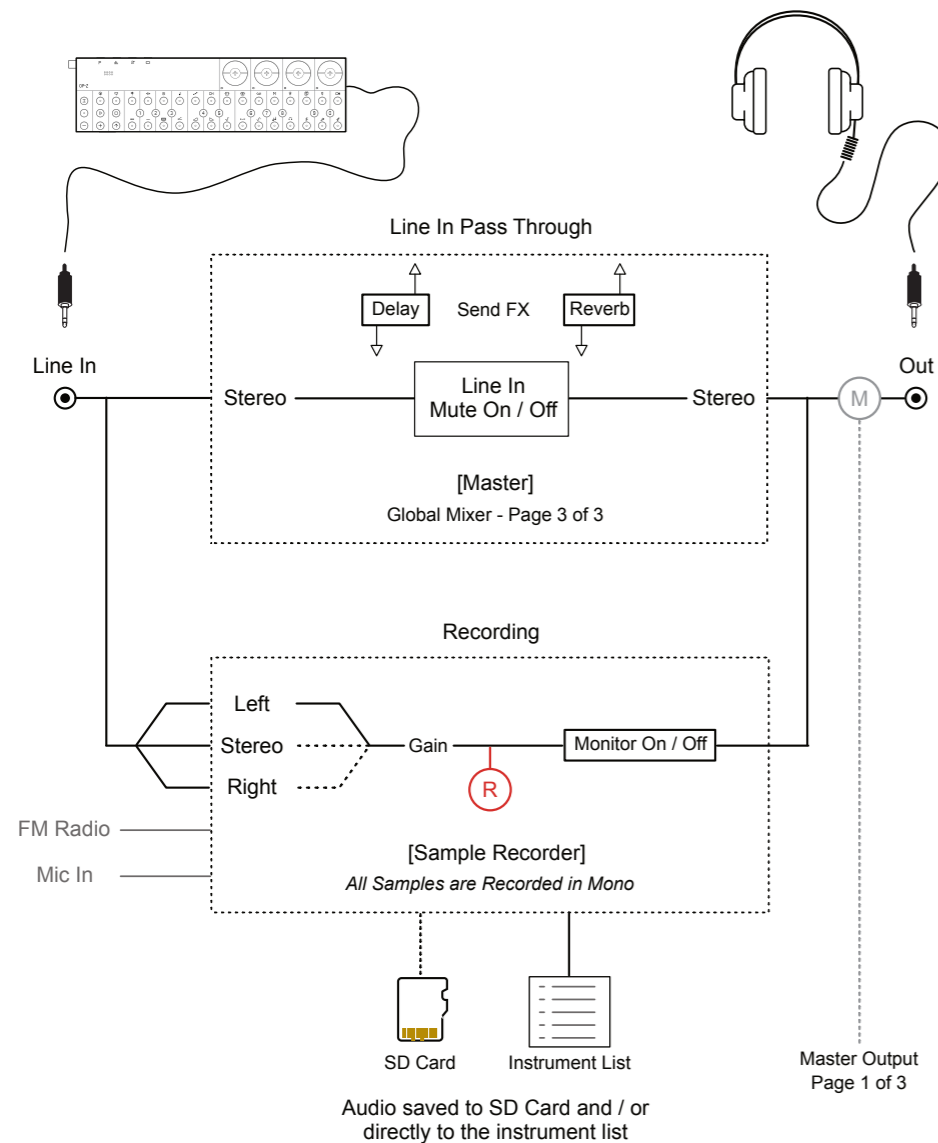

NOTES

NOTES

The sample recorder page can select sampling input, but the general input is defined in the 'Config' parameter settings. The Mixer passthrough audio operates in stereo.

SETTING THE SAMPLER LINE IN STEREO / MONO OPTION

1. Press [Config] to open the configuration settings.
2. Navigate with the 1st and 2nd Screen buttons to select 'General'.
3. In the central window pane, Press the 4th or 5th Screen buttons to navigate to 'Line in channel'.
4. Press [Change], 6th Screen button to select the options. The pop-up window will appear.
5. In the middle page pane, Press the 4th or 5th Screen buttons to navigate to select 'Stereo', 'Mono Left' or 'Mono Right'.
6. Press [Apply], 6th Screen Button or [Cancel], 3rd Screen button to exit without changing.

SETTING THE MIXER LINE IN PASS THROUGH PARAMETERS

1. Press [Master] to open the configuration settings. Navigate to the Global Mixer, Page 3 of 3, by Pressing [Master].
2. Line In by default is muted. Press [Unmute] 4th Screen button for the Line In channel to toggle mute / unmute. If unmuted this will be [Mute].
3. Line In can be soloed. Press [Shift] + [Solo] 4th Screen button for the Line In channel to toggle solo on or off.
4. Hold [Mute], 4th Screen button for Line In + Turn (Jog) to adjust level.
5. The Line in signal can also be sent to the master Delay and Reverb effect. These channels may also be muted. Press [Mute] / [Unmute] to toggle the Mute / Unmute State of the respective screen button.
6. To adjust the Delay and Reverb send amount, Hold [Mute] for the respective effect screen button + Turn (Jog).
7. The Mixer bar graphs will show the audio in real time for the level, dimmed if muted and bright if audible / unmuted. The level and send amount settings are also shown on the bar and in the label.

Mic Input

The microphone input is not represented in the mixer as it is just used for sample recording with no pass through, although audio monitoring does exist in the sample recorder. The input is a mono audio input connected by the 3.5mm mic in. A few things should be considered when using a mic.

- Tracker does not supply 48V Phantom power normally used for condenser microphones. Dynamic mics are therefore advised.
- The Mic selection input is in the sample recorder. Two options exist, Mic LG (Low Gain) and Mic HG (High Gain). The selection will depend on the microphone being used. Microphones with a strong driver on the input may need a lower gain setting to avoid clipping. Microphones with a weaker driver on the audio may need a high gain setting to ensure a better dynamic range.
- The microphone may use a stereo TRS or Mono TR connection, however recording from a microphone will always be in mono.
- Recording with a microphone follows similar principles to line-in. The gain may need more pre-adjustment before recording due to the nature of microphones and recording.

NOTES

8.4 FM Radio

Tracker has a built in FM Radio. This can be used for sampling and capturing various static or radio signals. Be aware of copyright when sampling radio especially if considering to release a commercial track.

Any cable plugged into the Audio Out jack will act as an antenna for the FM Radio.

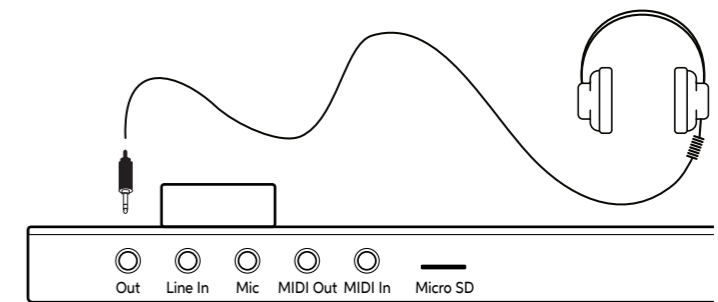

Sample Recorder
Hosts the FM Radio Tuner

Monitor audio to out

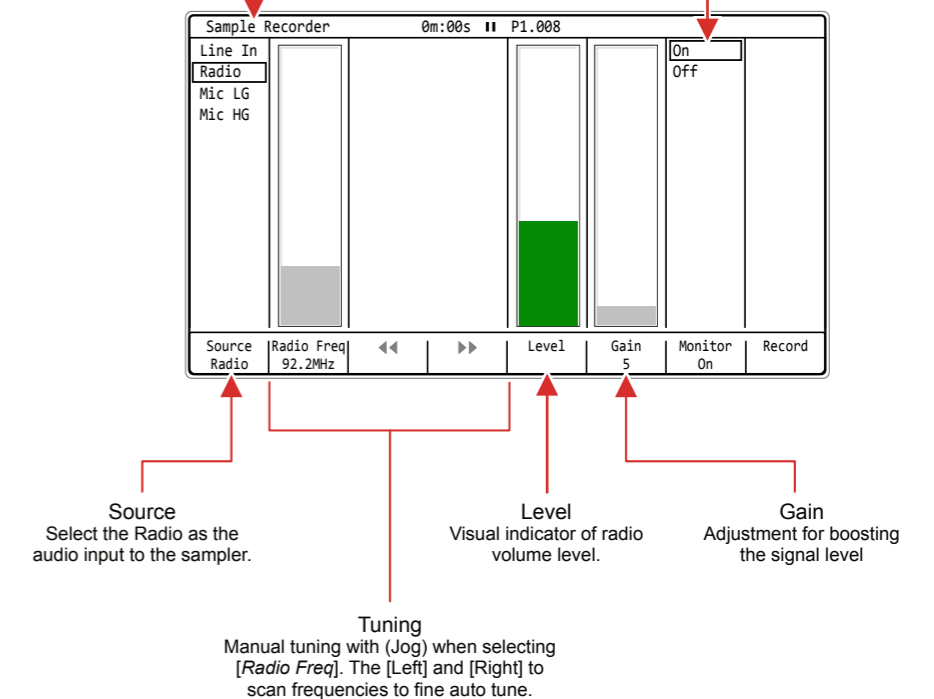

NOTES

The radio can be heard on headphones or from the audio out while monitoring is on in the sample recorder. Tuning is based on the region selected and signals in the range of the current location.

SETTING THE FM RADIO REGION

1. Press [Config] to open the configuration settings.
2. Navigate with the 1st and 2nd Screen Buttons to select the 'General' settings.
3. In the central window pane, Press the 4th or 5th Screen buttons to navigate to 'Radio Region'.
4. Press [Change], 6th Screen button to select the options. The pop-up window will appear.
5. In the central window pane, Press the 4th or 5th Screen buttons to navigate to select 'Europe', 'US', 'Australia', or 'Japan'. This adjusts the radio frequencies to suit the region, but try experimenting with settings.
6. Press [Apply], 6th Screen Button or [Cancel], 3rd Screen button to exit without changing.

TUNING THE FM RADIO

1. For best results plug headphones into the out connection to act as an antenna.
2. Press [Sample Recorder] which will allow access to the Radio.
3. Press [Source], 1st Screen Button, to toggle to 'Radio'.
4. Press [Monitor], 7th Screen Button to toggle monitoring the audio output on or off. Listen into the signal while tuning to find a desirable channel.
5. Press [Radio Freq], 2nd Screen Button.
6. Turn (Jog) to tune the frequency signal. Alternatively, Press 3rd or 4th Screen buttons.
7. If necessary, Press [Gain], 6th Screen Button. Turn (Jog) to increase or decrease the signal gain and audio level.

NOTES

NOTES

8.5 Sample Formats

The general principle when using trackers is to use short samples. Creativity often is inspired by limitations. While SD Card size is large and can hold a lot of high quality samples, Internal memory in Tracker is at a premium. The balance between quality and file size is an important one.

<p>Project Sample Time Up to 133 Second per Project (Mono) at standard quality audio imports.</p>
<p>Individual Sample Recording Time Maximum sample length is approx 45 seconds per sample</p>
<p>Sample Format The internal sampler engine operates at 44.1kHz, 16, 24, float 32 Bit, Mono, WAV audio files</p>
<p>Instrument List Samples can be loaded from the SD Card and into Tracker memory. A sample loaded to the internal list becomes an instrument.</p>
<p>Browser Import Format Uncompressed Wav files. Imported audio is converted to 44.1kHz, 16 bit, Mono.</p>
<p>Browser Import File Size Large files can be trimmed to import. Low quality import mode also possible to reduce the file size.</p>
<p>Rendered Output Files Stems created are PCM Wav files. The exported audio file is 44.1kHz, 16 bit.</p>

8.6 Recording Audio Workflow

Sampling in Tracker takes place in the 'Sample Recorder' page. This is the first step in the process and is followed by editing the audio captured. Sampling in this page can be from the Line In, Radio or Mic audio sources.

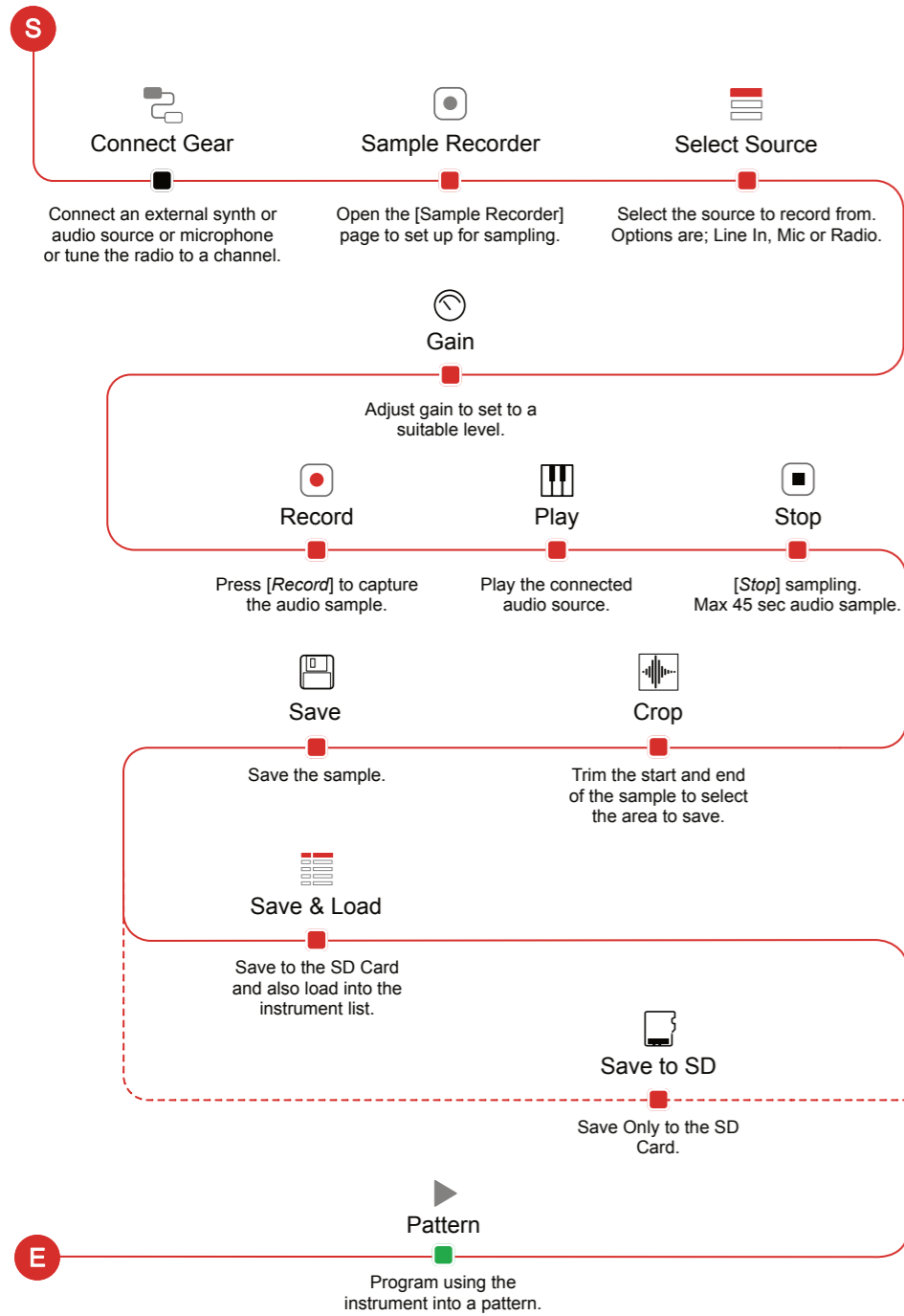

NOTES

8.7 Sampling

Everyone will develop a personal workflow for sampling and the process may differ due to the source to be recorded. Polyend Tracker allows approx 45 seconds of recorded audio time per sample and each project has a total of 133 seconds of mono sample time.

The main page used at the sampling stage is the [Sample Recorder]. Here the parameter settings can adjusted pre sampling. The selected source will determine the available options. Controlling the start and stop recording process is triggered within this page.

NOTES

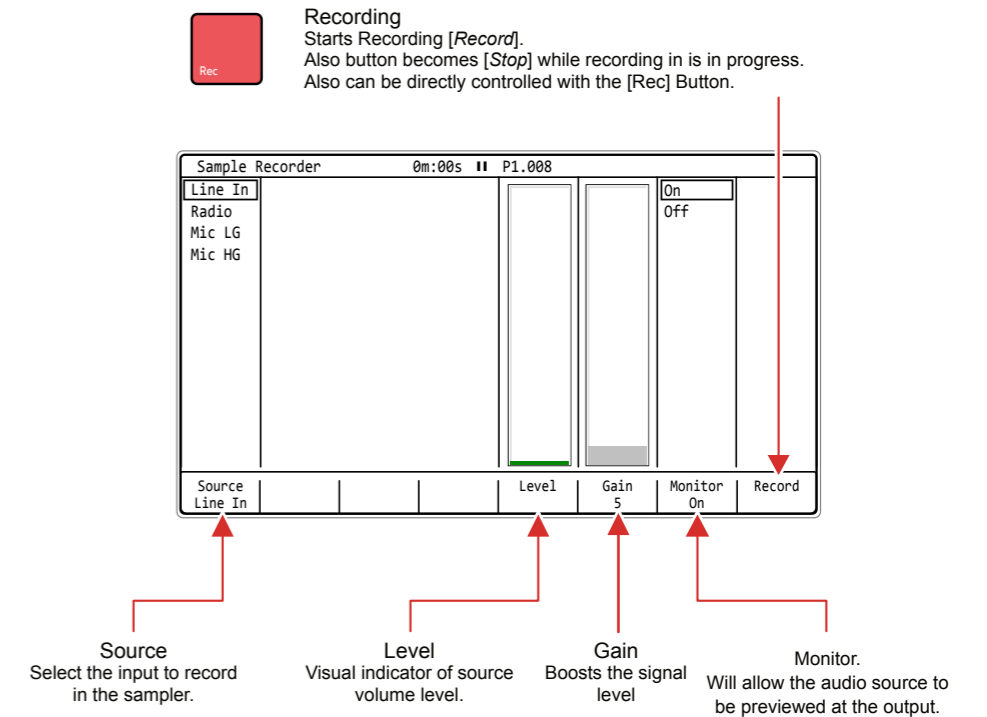

Sampling Process

Starting by selecting the [Sample Recorder] page

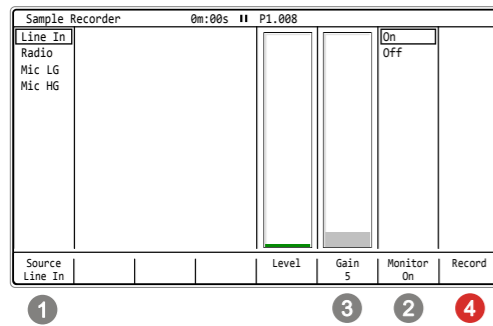

- 1 As pre-recording optional actions, select the audio [Source], set [Monitor] to on and adjust the [Gain] to establish a suitable recording level. External devices should be auditioned while adjusting the gain to hear the effect.
- 2
- 3
- 4 Press [Record]. 8th Screen Button, to start sampling the incoming audio.

Play the external device.

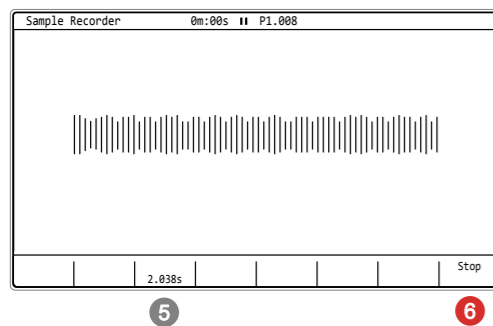

- 5 The sampler will capture the audio into the Tracker memory buffer and display the recording time. Recording will automatically stop if the memory is full at ~45 Secs.
- 6 Press [Stop]. 8th Screen Button, to manually stop the sampling process.

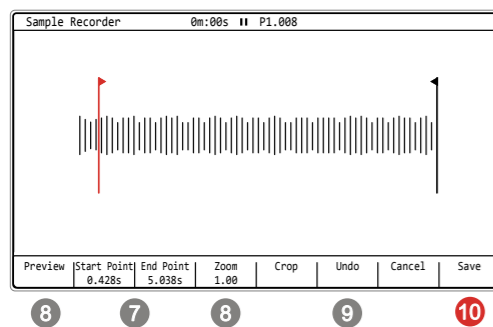

- 7 Trim the [Start] and [End] points of the recorded sample while previewing the audio to get the positions correct. Also [Zoom] in or out as a visual aid for precise editing.
- 8
- 9 The [Undo] option can reset previous state if errors are made.
- 10 Press [Save] when editing is complete. Alternatively Press [Cancel] to exit without saving. Confirm cancel with [Yes].

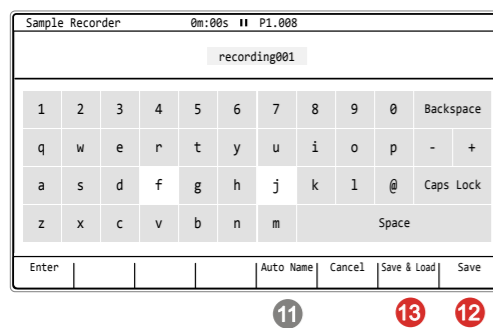

- 11 Type in a name for the sample or use [Auto Name] to generate a system name. Pads act as the qwerty keyboard, [Enter] will enter a highlighted character.
- 12 Press [Save], 8th Screen Button, to save the file into the SD Card 'Recordings' folder.
- 13 Press [Save & Load], 7th Screen Button, to save the file into the SD Card 'Recordings' folder and also load the sample into the instrument list. The instrument list will open with this option.

NOTES

NOTES

SAMPLING IN THE SAMPLE RECORDER

1. Press [Sample Recorder] to open the sampler page.
2. Setup the input and levels.
 - Ensure the correct input to record is selected, Press [Source], 1st Screen button to toggle selections.
 - Select monitoring ON, Press [Monitor], 7th Screen button to toggle.
 - Adjust gain to suit input level. Press [Gain] and Turn (Jog). Ensure audio to record is audible and at a good enough level. The Level meter should not be lit red but green / amber, approx 70%.
3. Press [Record], 8th Screen button or [Rec] to start sampling. It may be useful to play the device to record before starting to record or after depending on its nature. Recording time that has lapsed is displayed.
4. Press [Stop], 8th Screen button or [rec] to stop sampling. It may be useful to also stop playing the recorded device. If stop is not initiated, sampling will continue until the memory is full.
5. The sample can be cropped before saving. This allows removal of any gaps or unwanted audio at the start end. The [Zoom], 4th Screen Button + (Jog) may help to get close up to areas to trim.
6. Press [Start], 2nd Screen button, then Turn (Jog) to set the start point. Press [End], 3rd Screen Button, then Turn (Jog) to set the end point. It may be an iterative process to set both as desired.
7. Press [Crop], 5th Screen button to trim the sample to the selected start and end points. The sample is cropped and option to save presented.
8. Save the sample, Press [Save], 8th Screen button.
9. The sample can be manually named in the text editor window using the Pads as the keyboard (Slower - but text is more relevant to the sample type). Alternatively, Press [Auto Name], 5th Screen Button to set a system generated name (quicker - but less relevant).
10. Press [Save & Load], 7th Screen button. This saves to the SD Card 'recordings' folder and also loads to and opens the instrument list.
11. Alternatively, Press [Save], 8th Screen button. This saves directly to the SD Card 'recordings' folder only.

8.8 Rendering and Exporting Internal Audio

Sampling is the process of recording and capturing audio, typically from external sources in the 'Sample Recording' page. Sampling of internal audio is performed through a different process where the audio is rendered.

Rendering is available in two levels:-

- **Pattern Level.** The render function is available from within the 'Pattern' pages and is performed on selected parts of a pattern. This is useful to lock in FX1 / FX2 and send effects into an audio sample or to combine multiple note tracks, rendered together as a chord sample.
- **Project Level.** The export function is accessible in the 'File' pages. This will allow rendering of complete patterns, individual tracks, samples or entire songs, saving directly to an SD Card. This is useful to create full stems and mix / remix in a DAW, use in other package or distribute to others.

Quick Rendering a Pattern Selection

	Track 1	Track 2	Track 3	Track 4
1	D6 03 ----	E6 03 ----	D6 03 ----	D6 03 ----
2	D6 03 ----	E6 02 ---- F 4	D4 04 ----	D6 03 ---- T 50
3	D6 03 ---- V80	F6 02 ----	D4 04 ---- C 50	D6 03 ----
4	D6 03 ----	F6 02 ---- F 4	D4 04 ----	D6 03 ---- TSTP
5	D6 03 ----	E6 02 ---- m 5	D4 05 ---- C 75	D6 03 ----
6	D6 03 ----	E6 02 ----	D4 05 ----	D6 03 ----
7	D6 03 ----	F6 02 ---- m -5	D4 05 ---- C 75	D6 03 ---- T 50
8	D6 03 ---- V 60	F6 02 ----	D4 04 ---- C 50	D6 03 ----
9	D6 03 ----	D6 02 ---- TSTP	D4 04 ----	D6 03 ---- TSTP
10	D6 03 ----	D6 03 ----	D6 03 ----	D6 03 ----

Step Selection
A number of steps in a pattern, across various tracks can be rendered into one single sample. The pattern page is used with [Rec] mode on.



Folder location when using the render option in the pattern page.
/Export/ ProjectName/ Selection - Will save to current project name

NOTES

NOTES

RENDERING SELECTION IN A PATTERN

1. Press [Pattern] to select the pattern mode page.
2. Press [Rec] to select record edit mode.
3. Hold [Shift] + [Up], [Down], [Left], [Right] to select the range to render. For example, select across 3 tracks, 8 steps, of a percussion sequence.
4. Press [More]. The 8th Screen Button to select more pattern options.
5. Press [Render Selection], the 1st Screen Button. This will be dimmed and unavailable if [Rec] is off.
6. The naming page appears. A name can be edited or press [Auto Name], 5th Screen Button to automatically apply a name. Manually editing the name offers an opportunity to make the name relevant, although a longer process. Auto name may be less relevant in terms of the name, but is a faster process.
7. When the name is entered, Press [Render & Load], 7th Screen Button. This option will not only render the audio but also automatically load the sample into the instrument list. The pattern will halt playback if playing. When the file has been 'exported', the instrument list will open ready to preview and the sample selected.
8. Alternatively, Press [Render Selection], 7th Screen Button. This option will render the audio. The pattern will halt playback if playing. This will render and save onto the SD Card.
9. The SD Card save location is in the 'Export/ ProjectName/ Selection' folder for both render options. Rendered files are 44.1kHz, 16 bit. Files are accessible from sample loader.

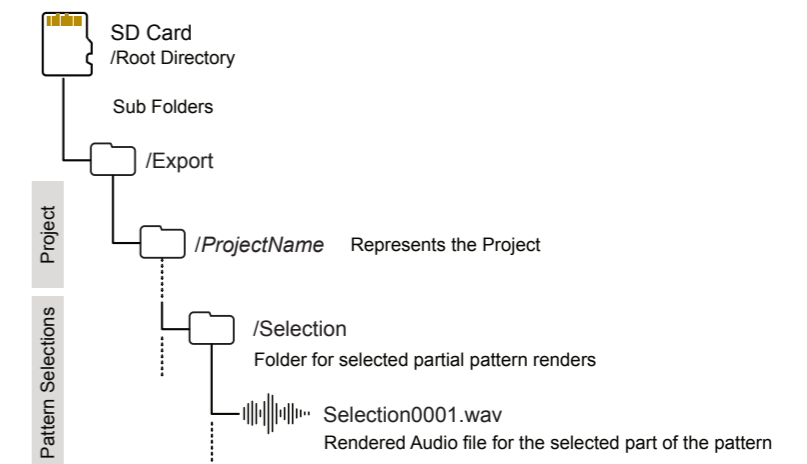

Rendering and Exporting Stems

The function to render and export full stems for tracks or full songs and patterns is found in the 'File' options. MIDI Clock IN must be set to Internal in the Config settings in order to render stems.

Press [File]

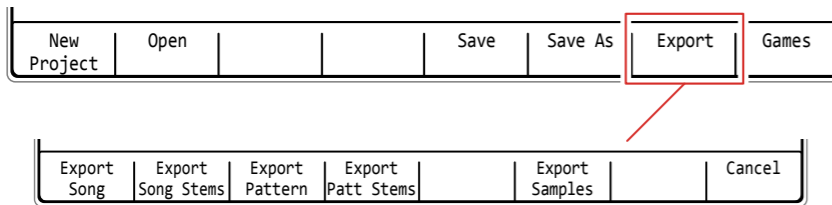

Folder location when using the render option in the file page.

/Export/ *ProjectName*/ Selection - Exports to the folder named for the current project

Function	Screen Button	Description
Export Song	1st	Renders an individual audio files for the selected song. Muted tracks are not rendered. The stem will cover the entire song length and are 44.1kHz, 16 Bit PCM Wav files.
Export Song Stems	2nd	Renders individual audio files for each of the 8 unmuted tracks and 2 effects, delay and reverb, all in mono. Muted tracks are not rendered. In addition a stereo mix of the complete song as an audio file. The stems will cover the entire song length and are 44.1kHz, 16 Bit PCM Wav files.
Export Pattern	3rd	Renders an individual audio file for the selected project pattern. Muted tracks are not rendered. The stem will cover the entire pattern length and are 44.1kHz, 16 Bit PCM Wav files. A unique folder is created to represent the render.
Export Patt Stems	4th	Renders individual and complete audio files for the project patterns. Muted tracks are not rendered. The stems will cover the entire pattern length and are 44.1kHz, 16 Bit PCM Wav files. This will render 11 stems (Tracks, Delay, Reverb and Master). A unique folder is created to represent the render.
Export Samples	6th	Exports the project .pti instrument files as .wav files. This captures instruments to audio. Exported to the SD Card within the folder, <i>Projects/ProjectName/samples</i> , named by the instrument name.

The rendering process is almost real-time based on the project duration (in fact song stems render approx 20% faster of the time duration of the playback) and operates by rendering stems one by one. This means when exporting stems the render time can be 2-3 times, maybe even longer than the original song duration. The render progress is displayed when in operation.

NOTES

NOTES

RENDER AND EXPORT A FULL PATTERN

1. Press [File] to select the file options page.
2. Press [*Export*], 7th Screen button to select the export specific options.
3. Press [*Export Pattern*], 3rd Screen button to render and export.
4. The currently active pattern will be rendered and exported. Any muted tracks are not rendered and therefore remain silent in the exported audio file.
5. A folder is created on the SD Card that represents the render. This is located in the /Export sub folder. The file itself will be called 'master.wav'. Each time the pattern is exported a new folder is created. The folder naming convention is:-

Project name_P Pattern number_Sequential render number

RENDER AND EXPORT ALL PATTERN STEMS

1. Press [File] to select the file options page.
2. Press [*Export*], 7th Screen button to select the export specific options.
3. Press [*Export Patt Stems*], 3rd Screen button to render and export.
4. All tracks plus the delay and reverb audio will be rendered in mono and exported. Also a stereo master file is rendered of all tracks. Any muted tracks are not rendered and therefore remain silent in the exported audio file.
5. A folder is created on the SD Card that represents the render. This is located in the /Export sub folder. The 11 files will be called 'track 1.wav' etc, 'delay.wav', 'reverb.wav' and 'master.wav'. Each time the pattern is exported a new folder is created. The folder naming convention is:-

Project name_P Pattern number_S for Stems + Sequential number

Rendered Pattern Locations

Rendered files are exported to the /export folder and new sub-folders are created for patterns and pattern stems. These are accessible from the sample loader function pages.

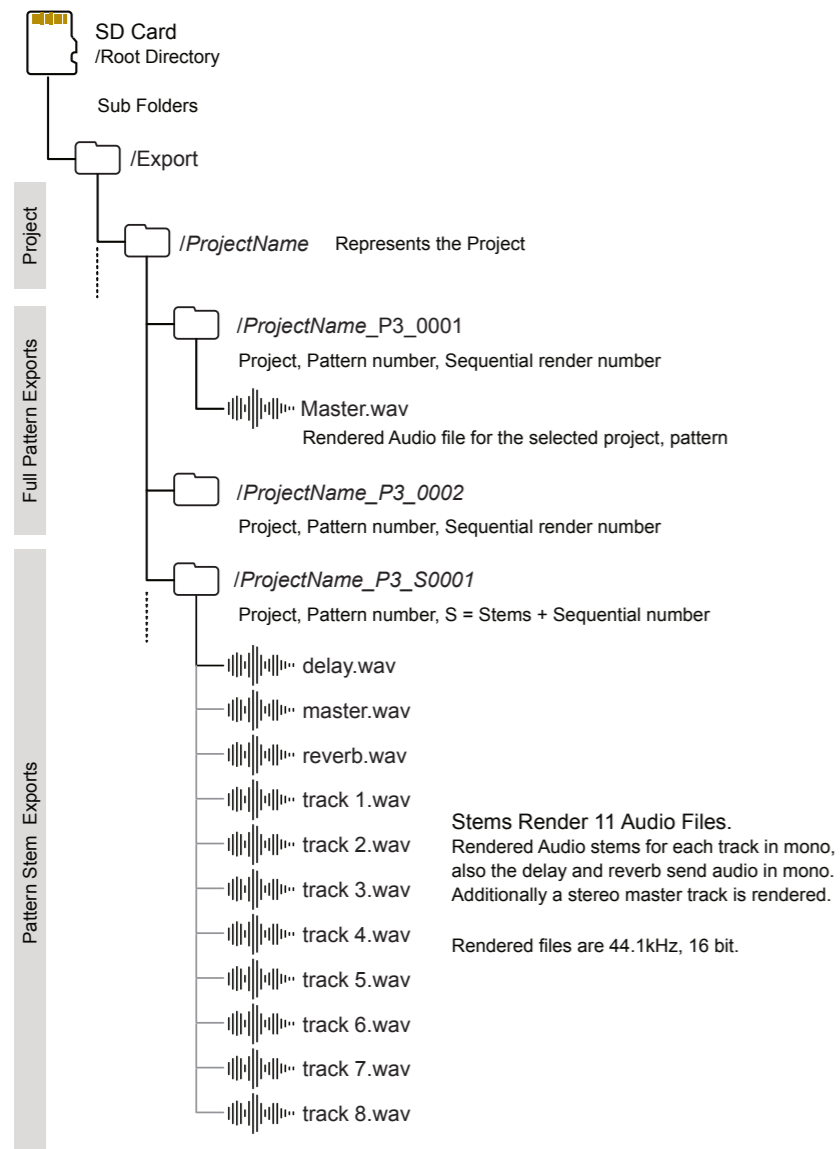

NOTES

RENDER AND EXPORT A FULL SONG

1. Press [File] to select the file options page.
2. Press [Export], 7th Screen button to select the export specific options.
3. Press [Export Song], 1st Screen button to render and export.
4. The current song will be rendered and exported. Any muted tracks are not rendered and therefore remain silent in the exported audio file.
5. A folder is created on the SD Card that represents the render. This is located in the /Export sub folder. The file itself will be called 'master.wav'. Each time the song is exported a new folder is created. The folder naming convention is:-

Project name_Song_Sequential render number

RENDER AND EXPORT ALL SONG STEMS

1. Press [File] to select the file options page.
2. Press [Export], 7th Screen button to select the export specific options.
3. Press [Export Song Stems], 2nd Screen button to render and export.
4. All tracks plus the delay and reverb audio will be rendered in mono and exported. Also a stereo master file is rendered of all tracks. Any muted tracks are not rendered and therefore remain silent in the exported audio file.
5. A folder is created on the SD Card that represents the render. This is located in the /Export sub folder. The 11 files will be called 'track 1.wav' etc, 'delay.wav', 'reverb.wav' and 'master.wav'. Each time the pattern is exported a new folder is created. The folder naming convention is:-

Project name_Song_S for Stems + Sequential number

Rendered Song Locations

Rendered files are exported to the /export folder and new sub-folders are created for songs and song stems. These are accessible from the sample loader function pages.

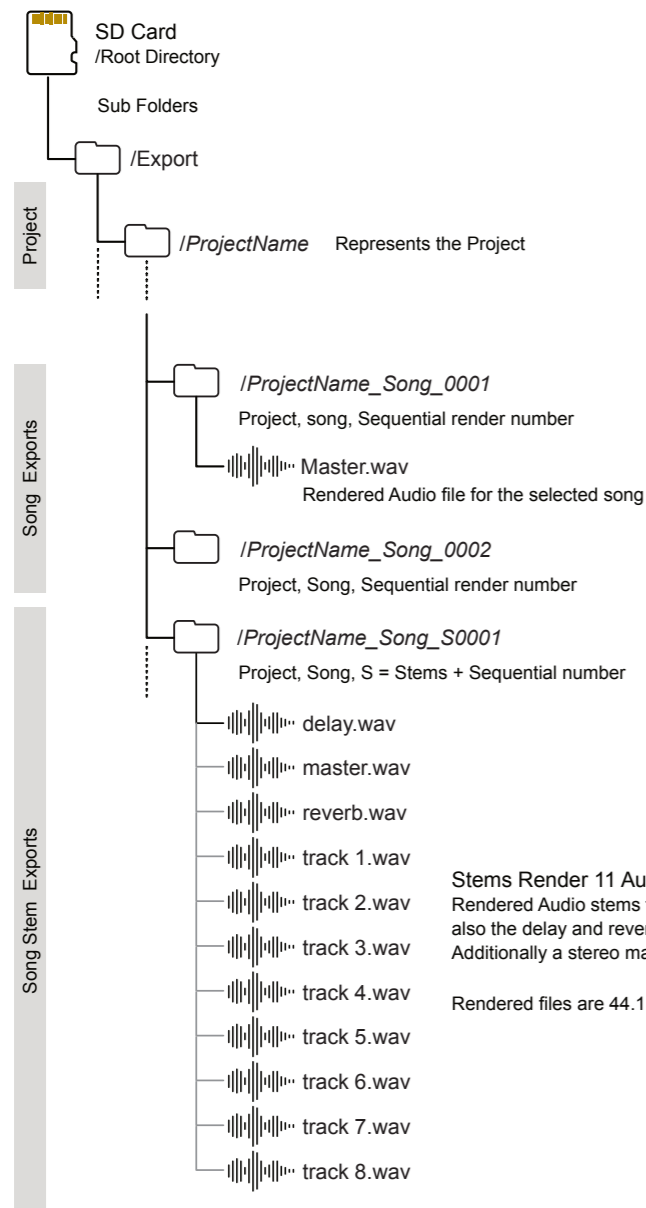

NOTES

8.9 Advanced Audio Editing

Sampling captures audio using the 'Sample Recorder' and provides basic editing features for quick and easy use of the sample in the project. An instrument can be selected from within the sample editor by holding [Instrument]. A more advanced set of editing features exists in the 'Sample Editor' which focuses on the currently selected sample. Press a Pad to preview the audio.

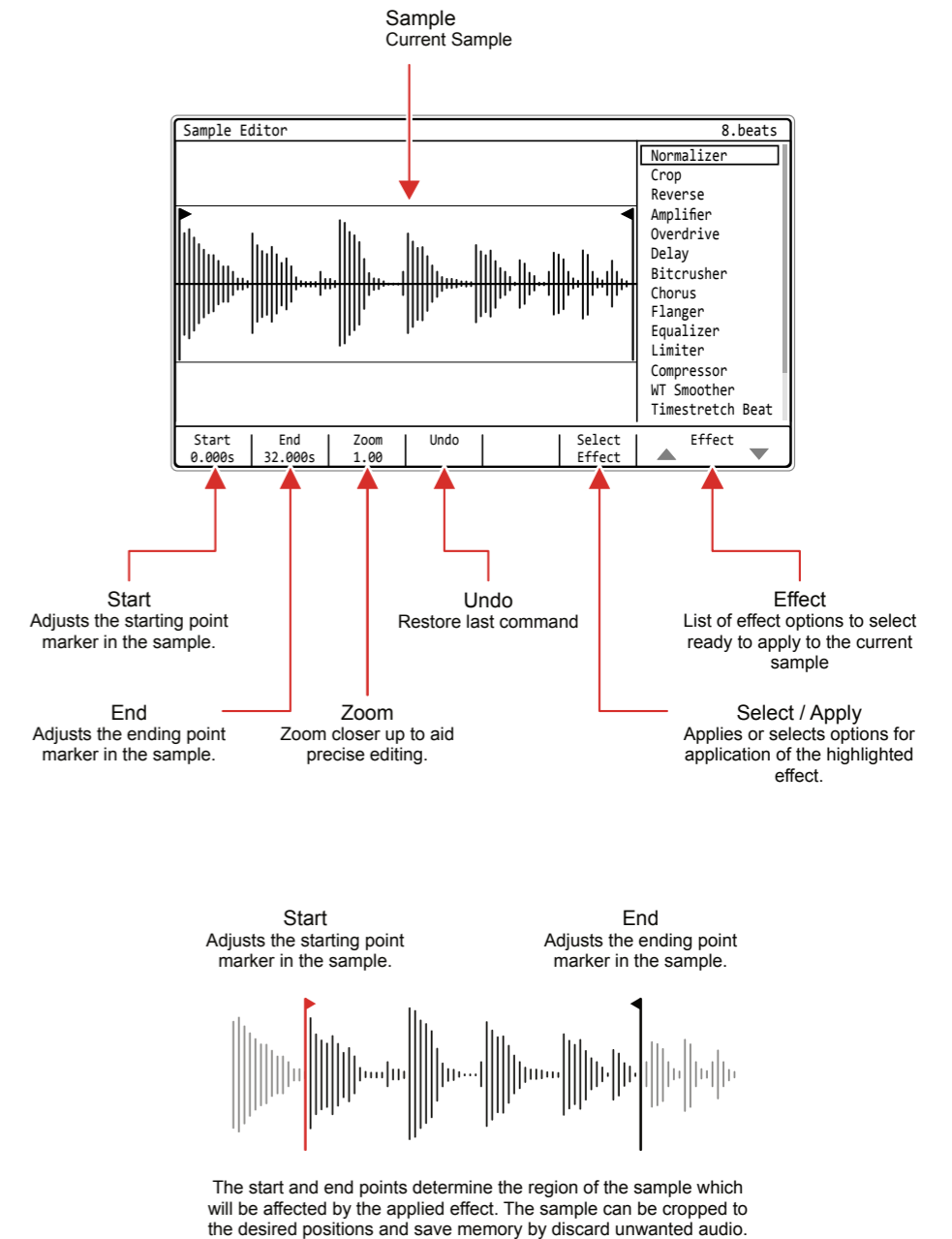

NOTES

Audio Effects Overview

These effects are applied destructively and baked into the selected audio sample in project memory. The undo command can restore a prior state unless saved. The original file on the SD card remains intact and is unaffected.

Effect	Description
Normalizer	Adjusts the gain on the selected sample or part of the sample between the start / end point. Gain will be based on the normalizer 0-100% level and will boost or attenuate the selected audio consistently across the selection.
Crop	Trims the audio at the start and end points and discards any audio outside of these settings. Useful to manage sample size and create samples with precise duration.
Reverse	Reverses the audio between the selected start and end point settings.
Amplifier	Amplifies the audio at the start and end points by the selected 'amplifier' level 0-5 in the effect. Effectively multiplies the sample or selection.
Overdrive	Adds distortion into the audio sample or selected audio between start and end. Three model types 0,1,2 are selectable as well as a gain adjustment.
Delay	Introduces delay into the audio sample or selected audio between start and end. Feedback and time parameters are adjustable before applying.
Bitcrusher	Bitcrushes the audio sample or selected audio between start and end. The number of bits can be adjusted between 1-16. Also sample rate can be adjusted.
Chorus	Chorus effect giving a classic multi layered instrument sound can be applied to the audio sample or selection. Number of chorus voices 1-8 and length between 2-92ms can be adjusted before applying the effect into the audio.
Flanger	Flanger effect giving a classic out of phase layered sound can be applied to the audio sample or selection. Several parameter settings can be adjusted before applying the effect into the audio. These include Length, Offset, Depth and Rate.
Equalizer	Equalizer also called EQ affects the frequency bands in an audio signal by boosting or attenuating. The 3-Band EQ can be adjusted before applying into the sample or selected part of the sample.
Limiter	A limiter is used to control or tame dynamic peaks by reducing or limiting the transients. Normally used as a corrective or control function and associated with loudness rather than a creative effect. Includes Threshold, Attack and Release parameters.
Compressor	A compressor is used to manage and reduce dynamic range. In this application it is used as a control function. The typical parameters of Threshold, Ratio, Attack and Release are adjustable before applying to the audio sample or selection.
WT Smoother	This is a tool used to optimise and convert audio into a sample more compatible with the wavetable play mode function. The wavetable window settings are adjustable before applying to the audio sample or selection.
Timestretch Beat	Creative manipulation tool to stretch the sample time which in turn affects the sound. Used more for beat based material. The tempo, steps, micro-step and granule are adjustable before applying to the audio sample or selection.
Timestretch Note	Creative manipulation tool to stretch the sample time which in turn affects the sound. Used more for melody based material. The length and granule are adjustable before applying to the audio sample or selection.
Fade In	Quick and easy application of a fade in to the audio sample or a selected part. This operates at a fixed setting across the start / end selected part of the sample.
Fade Out	Quick and easy application of a fade out to the audio sample or a selected part. This operates at a fixed setting across the start / end selected part of the sample.

NOTES

NOTES

8.10 Sample Editor Effects

The Sample Editor pages have more advanced destructive editing options. A comprehensive range of effects can also be applied to affect the audio either to correct or adjust or to create new sounds. Some effects are applied directly, while others have parameters and settings

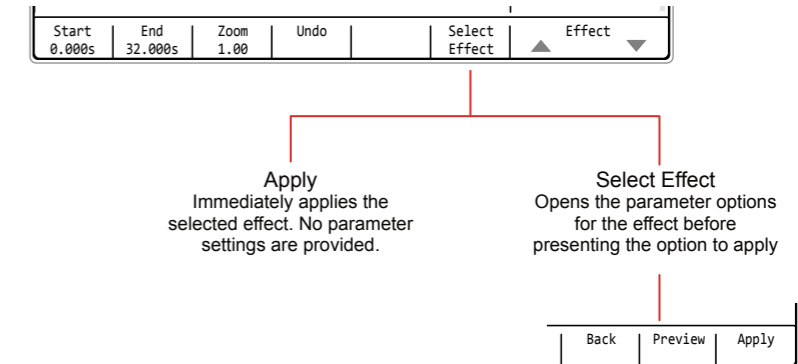

The preview option found in the selected effect sub-page will render the effect and audition the sample with the effect applied. In the main 'Sample Editor' Page, Pressing the Pads will preview the audio.

The effect is applied to the audio sample or the audio selected between the start and end points.

APPLYING AN AUDIO EFFECT

1. Press [Sample Editor] to select the audio edit options page.
2. Press [Start] or [End] and Turn (Jog) to adjust the sample selection area or leave the start and end at the edges to cover the complete sample.
3. Press [Effect], 7th or 8th Screen Button to navigate to the effect to apply.
4. With the desired effect highlighted, ie bounding box selection, press [Select Effect] or [Apply], 6th Screen Button.
5. The effect will either be immediately applied by pressing 'Apply' or will open the effect page if pressing 'Select Effect'.
6. If the effect page parameters are available, adjust as desired using the Screen Buttons and Jog control.
7. Press [Preview] 7th Screen Button to hear the newly affected audio.
8. Press [Apply], 8th Screen Button, to confirm and rendering the effect.

Normalizer and Amplifier

Both the Normalizer and Amplifier apply similar effects in that they adjust the gain across the audio sample or region. Normalizer gain will be based on the level setting where 100% will maximize the audio level across an entire sample by using the highest peak point as reference. This is a typical normalised application. Think of the Amplifier as a multiplier of the audio gain where 1 would be the current state and numbers below 1 will attenuate and above 1 will boost. Amplified audio can exceed the normal range

NOTES

Normalizer
Gain adjustment based on the 0-100% Level

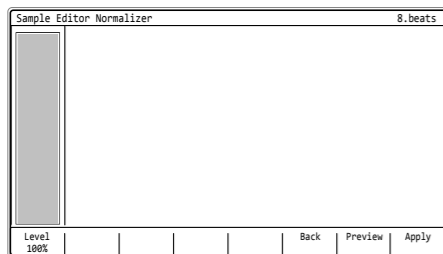

Amplifier
Gain is based on the 0.01 - 5 amplification range

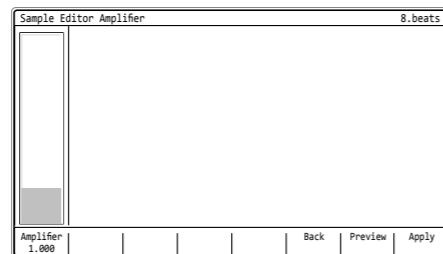

Crop and Reverse

Both the crop and reverse functions apply an immediate edit to the selected or the entire audio sample. Reverse simply reverses the audio playback direction while crop will trim and discard the audio outside of the start / end markers. Zoom may help focus on more precise marker setting locations.

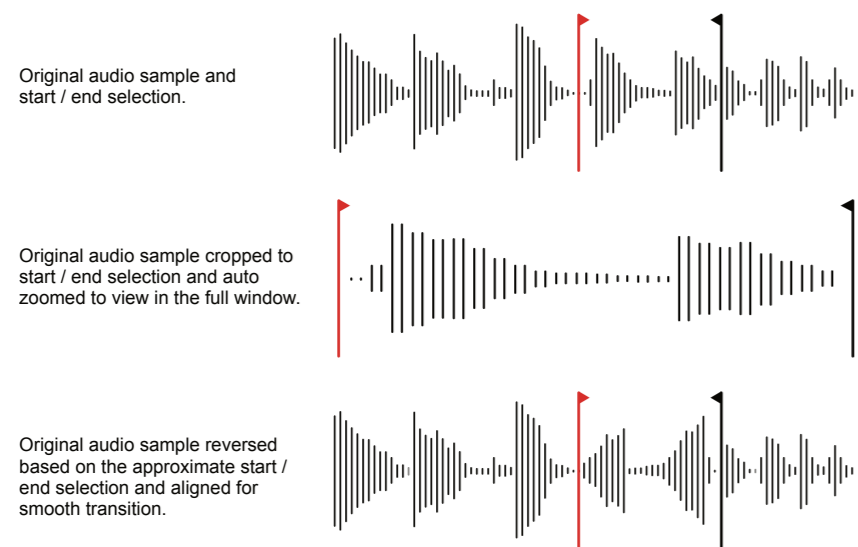

NOTES

Overdrive and Bitcrusher

Overdrive is a classic distortion effect based on driving the analog audio signal into an amplifier hard. This gives a grungy, edge to the sound or full on distortion. Given the aggressive nature of overdrive the gain adjustment is a welcome feature. Bit crushing is a process which also gives a distortion like effect and is based on lowering the digital quality down from a standard 16bit, 44.1kHz and introduces a LoFi style sound.

Overdrive
Three overdrive types are available.
Gain control from 0.01 to 5.000.

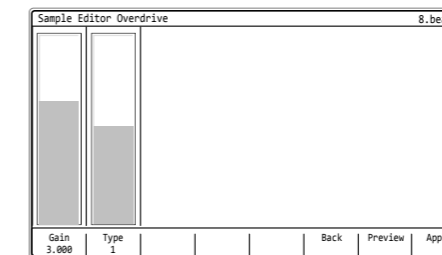

Bitcrusher
Bit reduction from 16 bit down to 1, sample rate also can be adjusted from 44100 Hz down to 500 Hz.

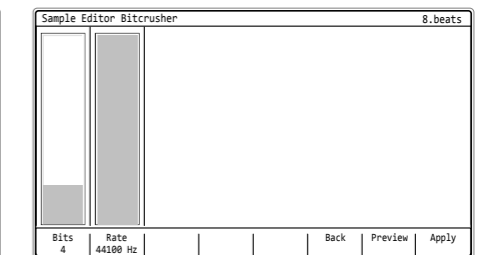

Delay and Chorus

The classic time based effects include delay and chorus. Delay creates an echo by delaying the audio signal and feeding back into the input. Chorus is similar to delay in that instead of feeding back it layers slightly delayed versions of the signal creating a thicker, wider sound.

Delay
Delay time 50ms to 5000 ms.
Feedback from 1% - 95%.

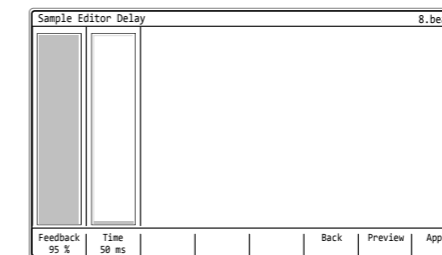

Chorus
Length has a range of 2 ms - 92 ms.
Voices refer to the layers of audio 1 - 8.

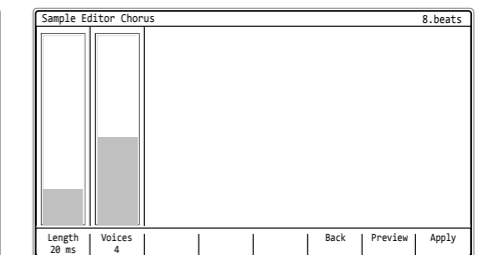

Flanger

Flanger follows similar principles to delay by doubling the audio and introducing a slight phase shift and delay between the audio signals when playing back. Flangers offer an evolving sweeping sound.

NOTES

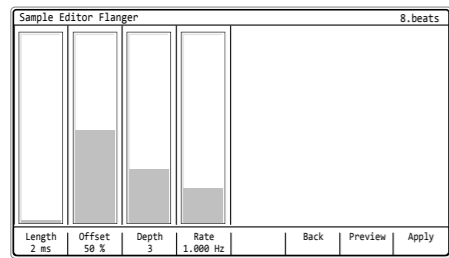

Depth
Amount of flanger effect applied.

Rate
Speed of effect modulation.

Length
Length of delay line between signals.

Offset
Offset percentage of delay in signal

Tweak by Ear

While the flanger and perhaps other effects have labelled functions, it is much more useful to tune these parameters by ear rather than by numerical positioning. The application of each parameter will give a different output depending on the source audio material. Sounds ranging from subtle tremolo to glitchy rhythms can be found by tweaking the flanger parameters by ear. The same applies to all of the creative audio effects.

Equalizer, Compressor and Limiter.

The three effects, Equalizer, Compressor and Limiter are used for mixing and finalising a sample rather than creative variations. In music production they often find themselves towards the end of a signal chain and are used to polish and finish off a track, gluing tracks together, developing a combined tonal balance, managing loudness and mastering a final release.

In the context of Tracker sample editing, the process operates at an individual sample level. However the same principles can be applied as those in general music production, to finish off and generate a final output sample. While these effects are applied individually they can also optionally be performed sequentially in order depending on what the objective is. An example shown below.

Example of Effect Chain / Order

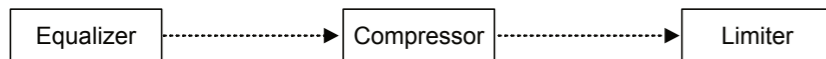

Balances tonal elements in a sound.

Provides harmonic emphasis to elements and makes space for others.

Can fix stray frequencies that affect the sound

Reduces dynamic range between high peaks and low troughs, allows overall level adjustment.

Can help sounds sit into a mix better. Layered compressed / uncompressed adds punch.

Create headroom.

Restricts and tames excessive audio peaks in a sound.

Maximises output levels and introduces a perceived loudness.

Protects digital integrity of a sample by avoiding clipping.

NOTES

Tweaking and trying different settings is encouraged on creative audio effects. While this is also possible on the process orientated tools, it is also recommended to get to know these parameters functions and purposes and have a basic understanding of their operation.

Equalizer

The purpose of an equalizer, also called EQ, is to boost or attenuate frequencies in an audio signal to either adjust the tonal characteristics or to fix unwanted frequency elements. Equalizers are typically used to shape a sounds character but also to allow a sound to sit comfortably alongside another. The sample editor EQ effect has 3 frequency bands. More coverage of general EQ functions is provided in the Master Effects section.

Page 1 of 3

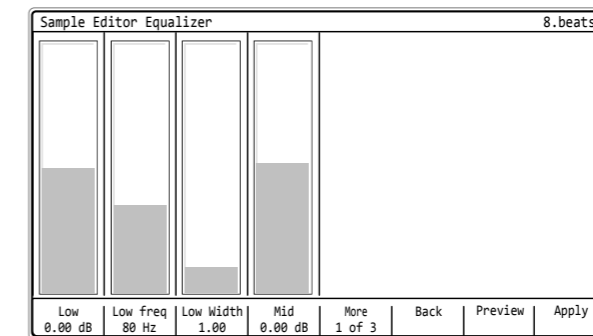

Page 2 of 3

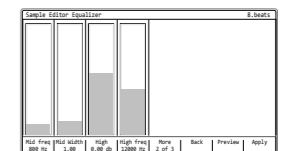

Page 3 of 3

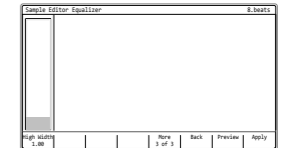

EQ Function	Description
Low	Low attenuation or boost amount, -12 dB to + 12dB.
Low Freq	Low Frequency range, 10Hz - 200Hz
Low Width	Width of EQ, also called Q. Range 0.5 to 5.
Mid	Mid attenuation or boost amount, -12 dB to + 12dB.
Mid Freq	Low Frequency range, 100Hz - 8KHz
Mid Width	Width of EQ, also called Q. Range 0.5 to 5.
High	High attenuation or boost amount, -12 dB to + 12dB.
High Freq	High Frequency range, 8KHz -20KHz
High Width	Width of EQ, also called Q. Range 0.5 to 5.

Equalizer Frequency Ranges

An equalizer can boost or attenuate frequencies across a range. The range of normal human hearing considered in music production is 20Hz to 20kHz. The character and tonal shape of a sound can be affected by the adjustment either boosting or attenuating at points on the frequency range. This is possible within Tracker using the EQ function.

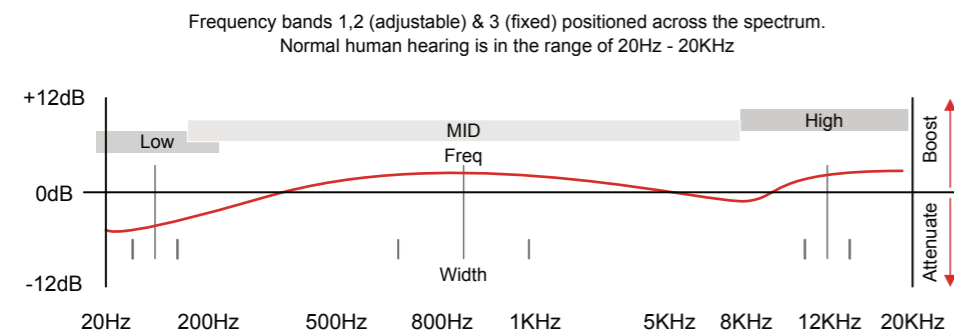

SUB BASS

High levels of energy, often a low cut removes some 'unheard' energy and helps create headroom. Typically frequencies would be cut in this area to create clarity. Emphasis for Sub Bass, Bass and Kick Drums. Sub bass is considered the low frequencies up to 80Hz.

BASS

Typically an area which contains melodic and rhythmic elements. The mix can be changed to be fat or thin by adjustments around this area. Muddiness occurs around 300Hz so a small cut can help clarity of the mix. The mix can be warmed up around 120Hz.

MIDS

Low Mids can be overloaded with frequencies as many instruments cover this range and muddiness is a common outcome. Honkyness can creep in around 500-1K and tinniness 1-2K. Cuts can help. Vocal frequencies appear in the high mid range around normal words. 3K boost on vocals can help push through the mix. Ensure the balance between instruments and vocals is correct.

HIGH

Sibilance occurs between 5-10K and letters such as S, T can stand out. De-essing can help. Typically a high shelf can add air and presence to the mix around 6K+. EQ'ing around 4-6K will affect the definition and bring the sound closer or push them further back.

NOTES

NOTES

Compressor

A compressor essentially works on a signals dynamic range (difference between audio peaks and lows). Often a compressor is used to reduce the dynamic range and then allow an increase of the overall signal gain to give more punch and impact. It can also sound dull if overdone as the nuances of the dynamics are reduced. Compression techniques can extend further when layering a compressed sound (to give the impact) with an uncompressed sound (to give the dynamic subtly). This technique is sometimes called Parallel or New York Style Compression. In tracker this can be created with two tracks one with compressed and other uncompressed then rendering to a single stem or sample.

How does a compressor work?

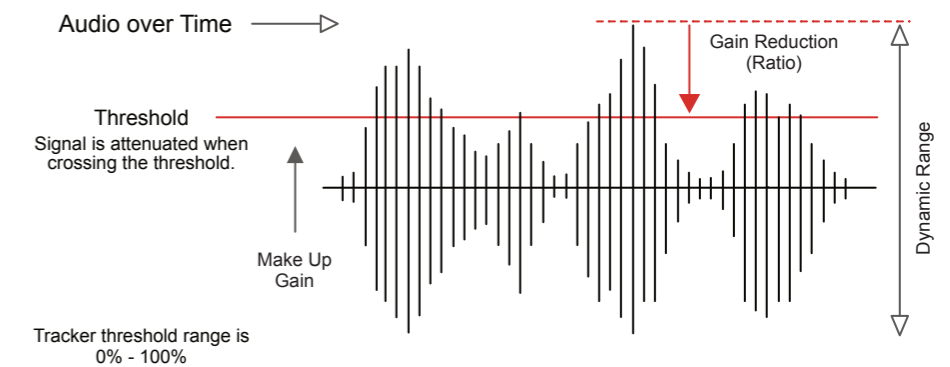

In basic terms a compressor reduces the level of any audio that exceeds a threshold. Think of this as an automatic volume control. The amount of gain reduction is determined by the ratio parameter. A ratio of 1:1 has no gain reduction while a gentle 2:1 will reduce by 1dB for every 2dB above the threshold. Higher ratios are more aggressive. The speed and reaction of the compressor is also governed by an envelope, in Tracker this is an Attack and Release envelope.

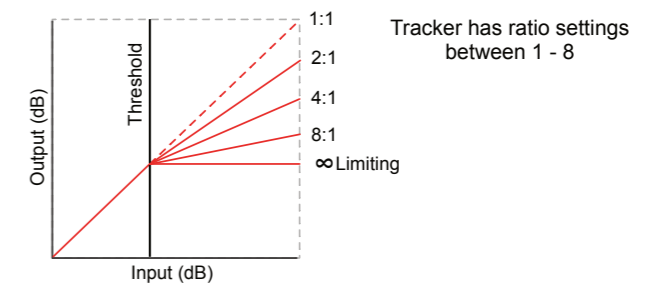

While compression is normally seen as a master effect on many devices and in DAW's, Tracker does not have a compressor in the master chain and relies on the master limiter. A compressor does however exist in the audio effects which can be rendered into the sample.

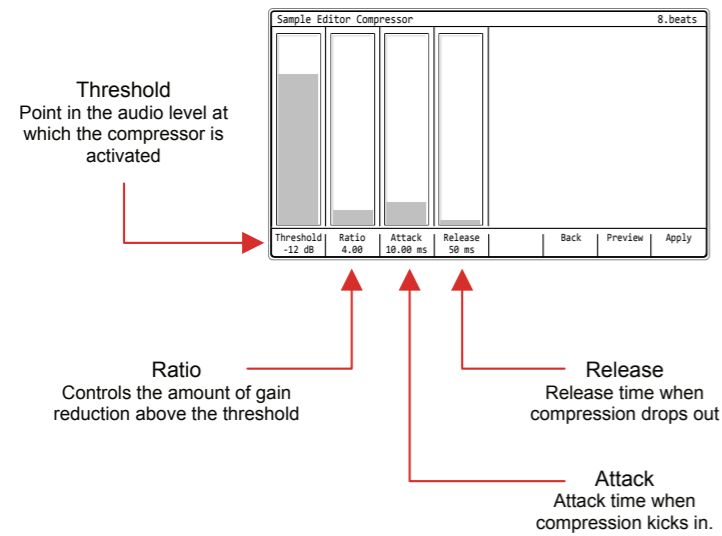

Limiter

A limiter is a similar utility to a compressor. In fact when high ratios are used in a compressor, say 20:1, it is considered to be limiting. A limiter essentially protects audio integrity and avoids excessive peaks by attenuating any peaks above a defined threshold.

How does a limiter work?

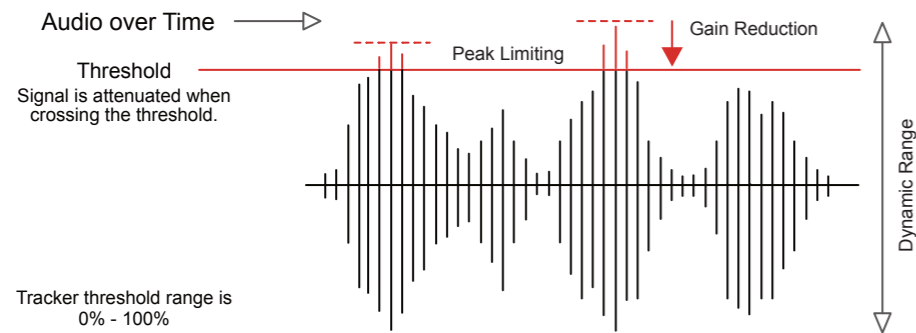

NOTES

NOTES

Tracker's limiter has the basic features of threshold which is where limiting will kick in and also an attack / release envelope which shapes the behaviour of the limiter function.

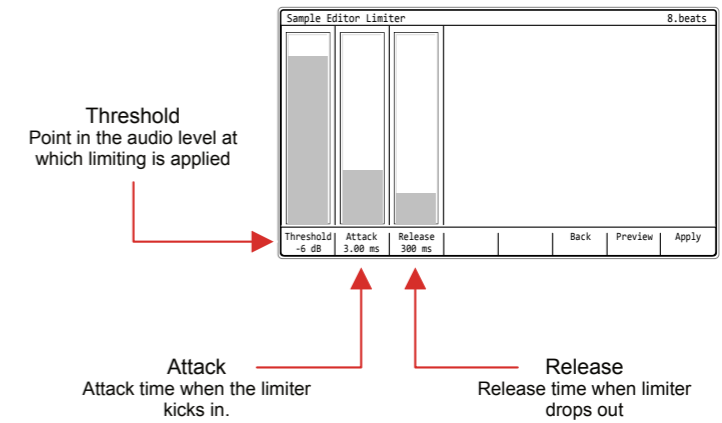

WT Smoother

The WT Smoother is a utility for converting normal audio samples into a format more compatible with the wavetable play mode synth. Essentially this optimises the interpolation between waves in a sample giving a smoother transition across the sample. More details of the Wavetable synth is provided in the instrument section.

Timestretch Beat and Note.

Two timestretch functions are available in the sample editor toolkit. Timestretch is a feature that adjusts the time of an audio sample, extending or reducing its duration without affecting pitch. Timestretch beat has parameters that are better applied to rhythmic material such as drums and percussion. Timestretch note is more aligned with melodic material.

NOTES

NOTES

Timestretch Beat

Tempo and Steps are used to define the duration of the affected sample. Granule will affect audio quality.

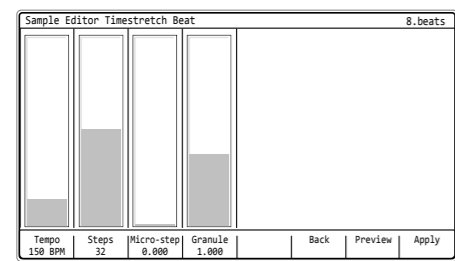

Timestretch Note

Length is used to define the duration of the affected sample. Granule will affect audio quality.

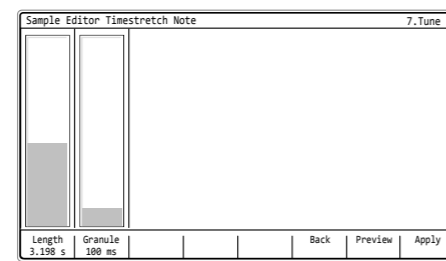

Examples

Max 64

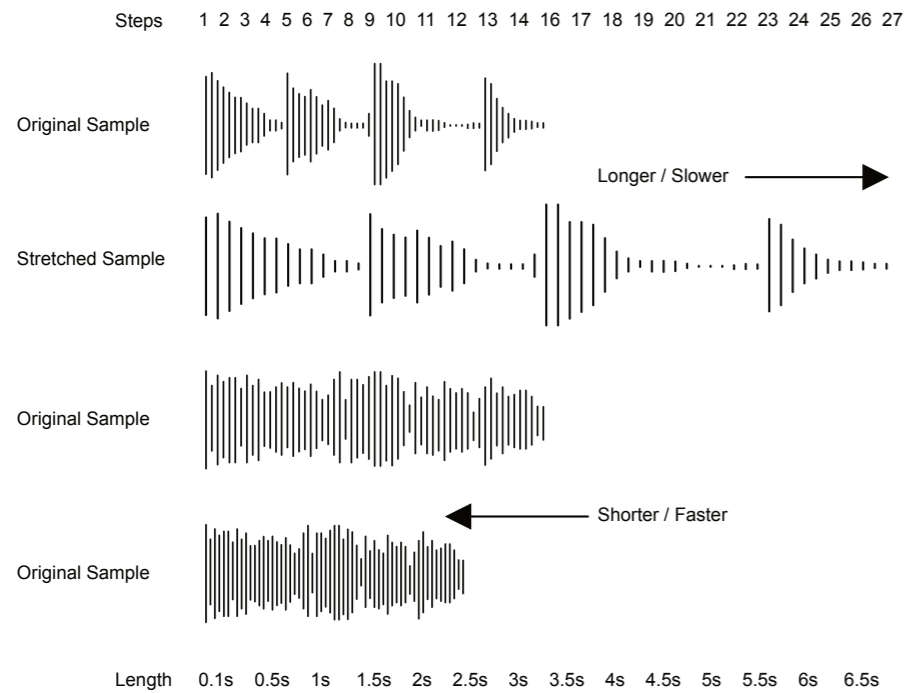

Max 8s

Fade In and Fade Out

The fade in and fade out utilities create a ramp up of audio level or a ramp down of audio level. The effect is applied to the audio selected between the start and end markers. Typically this would be applied at the start or end of an audio sample but equally can be applied anywhere based on the selected part of the audio sample. The effect is applied immediately with no adjustable parameters.

Examples

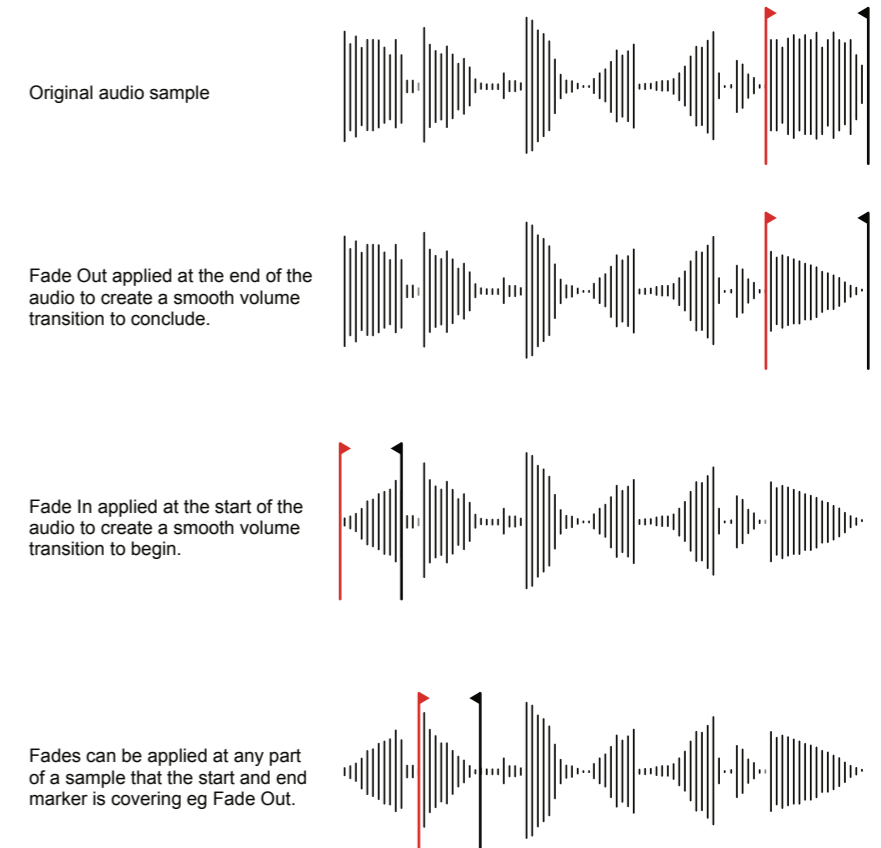

Song Mode

Steps are the most rudimental part of tracker, bringing together an instrument, effects and a note. Steps are combined with others to create beats and melodies within a pattern. Patterns are the snippets that form a small tune or riff. A song is the highest level of structure in Tracker and allows the combination of patterns to play a full 'song' and all of its components. Each project can have 1 song, which can hold a maximum of 255 pattern slots. Song mode is the environment in which to therefore arrange patterns to form the end to end song as well as re-arranging tracks. It allows, for example the positioning of patterns to create an introduction, build ups, breaks, drops, bridge, and outro also to introduce new elements through an ambient track. Song mode can be selected by pressing [Song] and also the song page can be temporarily displayed by holding [Song] which gives a quick access option. Song mode is the last part of arranging a full

track. Song stems can also be fully rendered out as audio to be used in another application to finalise a mix or for mastering or to be used to create remixes. The entire song, all tracks can also be rendered out as the final version too. As a reminder, as well as having the features for building song arrangements, song mode is also where the master tempo of the entire track is located. This can be adjusted quickly by holding [Song] + Turn (Jog).

9.1 Tempo

While tempo has been covered earlier, it is a good point to remind about the tempo setting which resides in the song mode pages.

SETTING THE TEMPO

1. To quickly set the tempo, Hold [Song] + Turn (Jog). Quick changes of the jog wheel will move in bigger increments. Also [Up] or [Down] can be used instead of (Jog).
2. The longer, on page option to change tempo, Press [Song] to select song mode.
3. Hold [Tempo], 8th Screen button and Turn (Jog) to adjust in 1BPM increments. Also [Up] or [Down] can be used instead of (Jog).
4. Hold [Tempo], 8th Screen button + [Shift] + Turn (Jog) to adjust in fine 0.1 increments. Also [Up] or [Down] can be used instead of (Jog).
5. Note that tempo changes can be applied also at step level using the step effects.

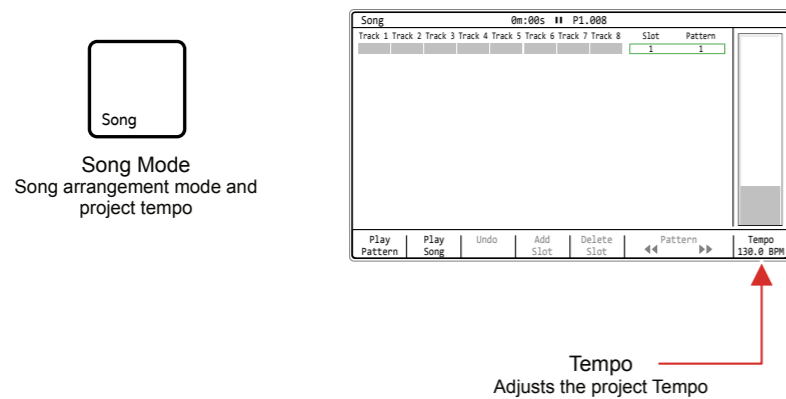

NOTES

9.2 Arrangement Overview

An entire song track consists of a number of variations that maintain the listeners interest and define its style and even its genre. Patterns are where the variation in sound, tone, key etc are made and the song mode is where variations in the structure are created. There is no fixed model and creativity comes from how songs are arranged as much as the instruments and melody applied. The example is used for illustration purposes.

Example: A typical EDM song structure + Example Patterns

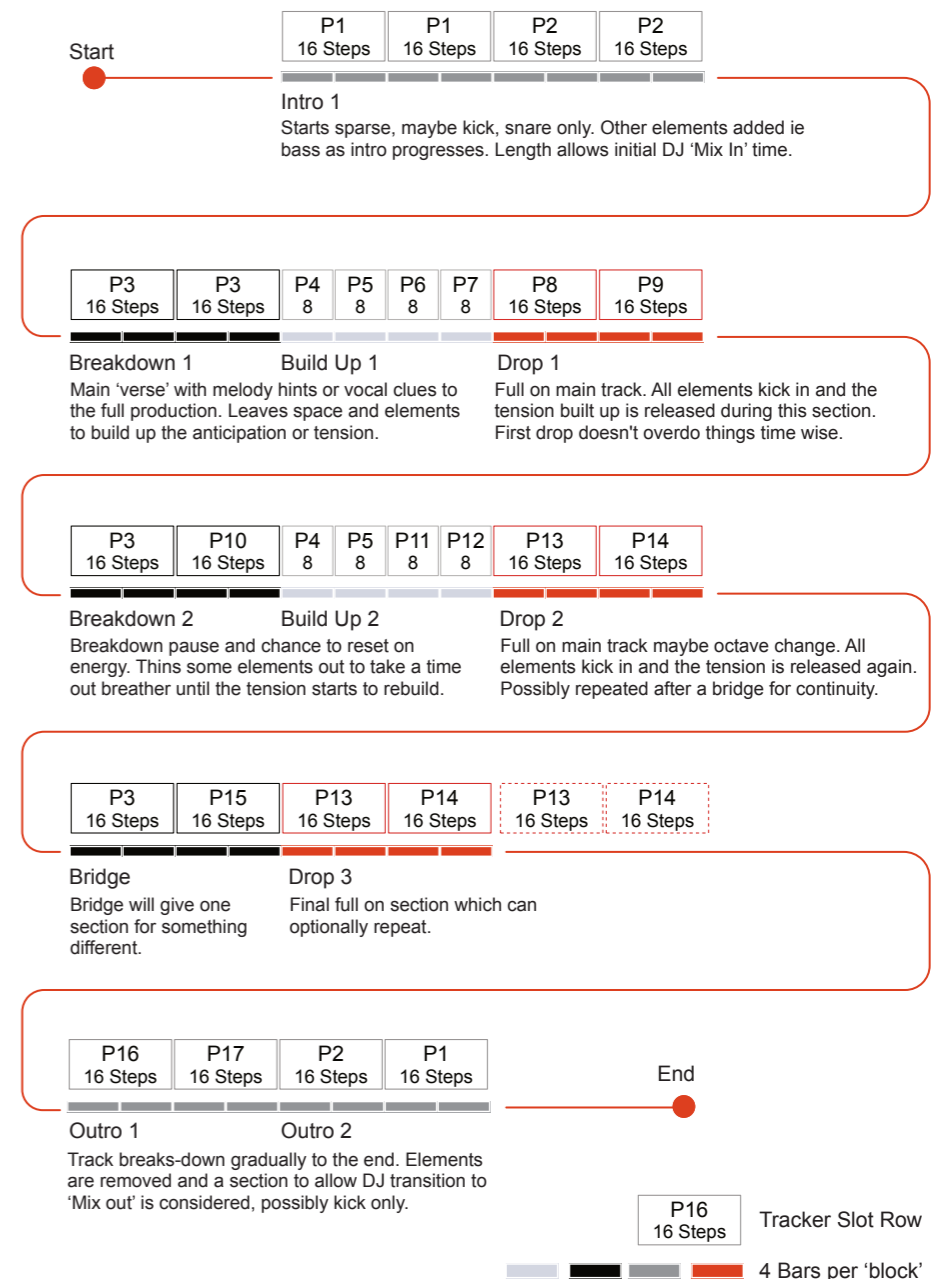

The song mode utility will help construct the patterns into a full song arrangement, recognising muted and empty tracks.

In order to use song mode a collection of patterns will be required to select from. Typically this may be newly created patterns or patterns edited as a variation from a base pattern. For example the same pattern can be copied then transposed and parts muted then saved as an alternative version.

Patterns cannot be named in Tracker and are managed in the pattern page as Pattern 1, Pattern 2 etc, loaded into the song utility as 1,2 etc and stored on the SD Card as pattern_01.mtp, pattern_02.mtp etc. It is advised to adopt some form of noting each pattern and it's function and features.

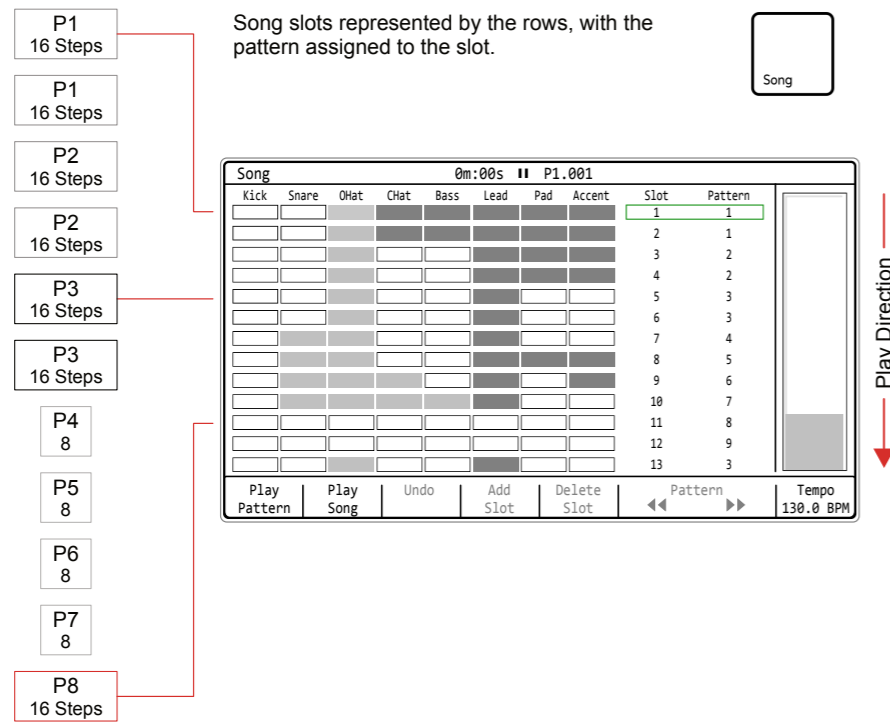

Each project can have 1 song, which can contain a maximum of 255 slots.

NOTES

NOTES

9.3 Song Mode Interface

Select the song page by pressing [Song] or hold [Song] to temporarily display the page from within another page, reverting back to this page when [Song] is released. The interface for song mode is by default empty other than a single slot 1 with pattern 1. Up to 255 Song slots are available. Pressing [Play] in song mode will play the song not just individual pattern. Tracks in a pattern for the slot are represented as cell clips.

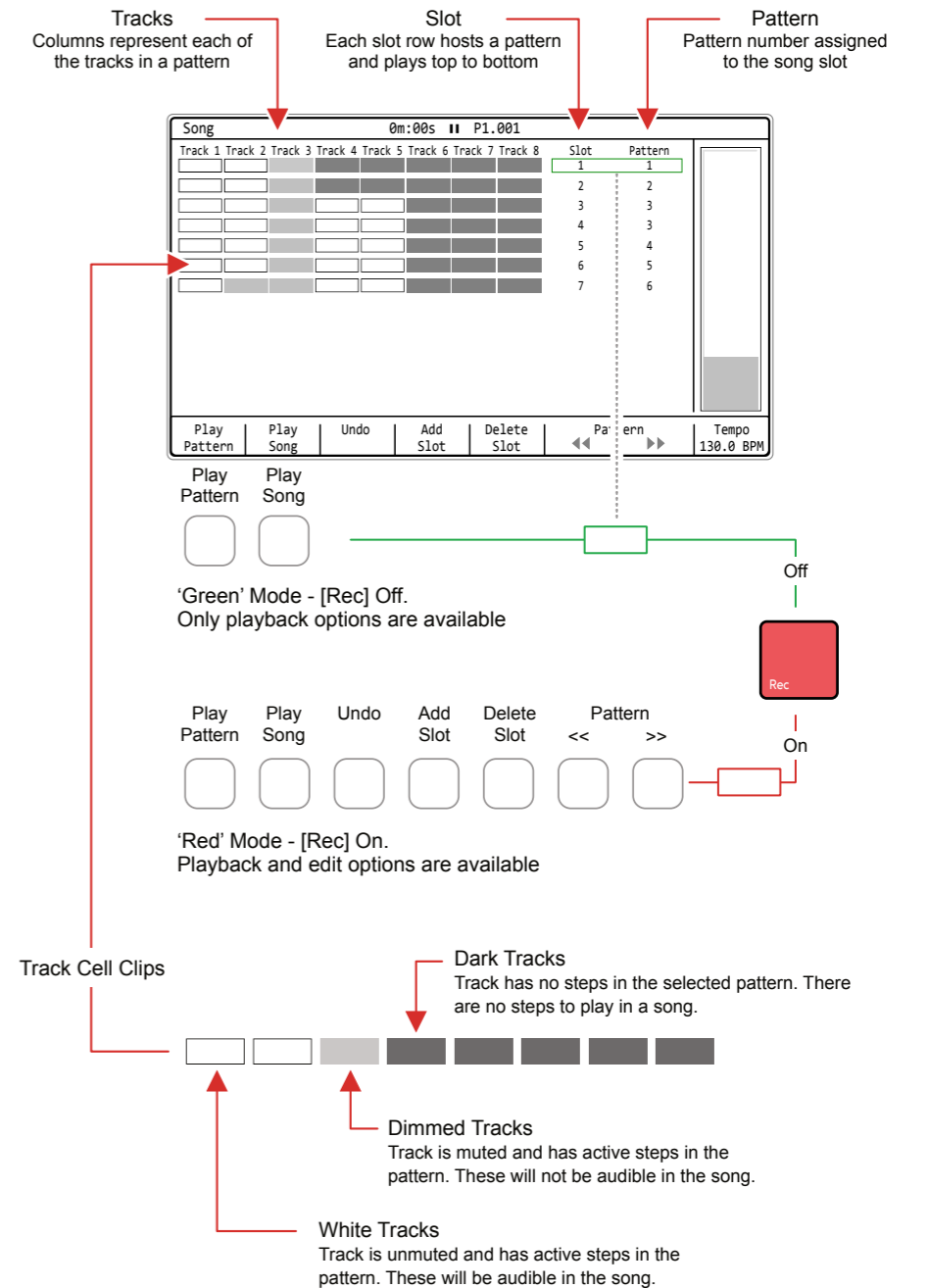

Muting Tracks
Muting is not performed in song mode. Use the Pattern page or the Track Mixer - Master Page 2/3 to mute / unmute.

9.4 Song v Pattern Relationship

Patterns can be arranged into a song in the song mode utility. Patterns selected in a song will also be available in the pattern mode and will appear in song mode as muted / unmuted inline with the status in pattern mode.

Editing tracks in song mode will reflect in pattern mode, tracks can be copied and pasted within song mode which will also be edit the pattern.

Patterns are muted in pattern or master pages and are reflected in the song mode clip shade as an empty clips. Tracks edited in Song Mode will in turn edit and reflect in the actual pattern.

When pressing [Play] in Pattern mode, switching to Song Mode will only show the selected pattern being played.

Pattern 1	Pattern 2	Pattern 3	Empty Unmuted
Track 1 P-25	Track 2 H-25	Track 3 P-20	Track 4 A 4
C5 40 P-25	C5 02 P-20	C4 12 A 4	
C5 40 P-25	C3 04 P-20	C4 12 A 4	
C5 M02 P-25		E5 M02	
	D3 04 P-10		
	D3 04 P-10		
	D3 04 P-10		

Song Mode and Pattern Mode can be in the same or different 'Red' - Edit On or 'Green' - Edit Off States.

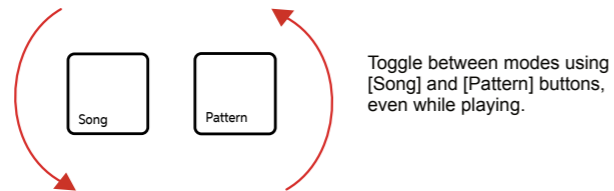

Toggle between modes using [Song] and [Pattern] buttons, even while playing.

Track 1	Track 2	Track 3	Track 4	Track 5	Track 6	Track 7	Track 8	Slot	Pattern
								1	1
								2	2
								3	3
								4	3
								5	4
								6	5
								7	6

While pressing [Song] will select the song page, holding [Song] button with a long press from within another page will temporarily display it.

Patterns in Song Mode will reflect the track condition from the pattern view including mute states, step position etc. This is shown by the shade of the track slot and the header position.

Tracks can be re-ordered by copy / paste in Song Mode. This in turn will edit the actual pattern and as such also be reflected in the pattern view.

When pressing [Play] in Song mode, switching to pattern mode will show each pattern as it is being played in the song structure.

9.5 Creating and Editing a Song

The pre-requisite to creating a song is to have a series of patterns available, although technically blank patterns can also be added to a song slot. Editing and creating a song is performed in 'Red' mode i.e. when the [Rec] mode is selected as on. Otherwise the song mode page just presents the playback of patterns and the song as options. Track muting is not applied in Song Mode, but is set in the Pattern or Track Mixer Pages.

CREATING A BASIC SONG FROM SCRATCH

1. Press [Song] to select song mode. The step / pattern cursor will be displayed by a green bounding box. Also only 1st and 2nd screen buttons to control play are available in 'green' mode - [Rec] off.
2. Press [Rec] to toggle editing on, 'red' mode. The step / pattern cursor will be displayed by a red bounding box. Also all of the screen button options are shown as available in 'red' mode - [Rec] on.
3. Navigate to the slot location desired, Turn (Jog). The location selected is shown with the green or red bounding box over the slot number and pattern number. Alternatively Press [Up] and [Down] to also navigate through the slots. Press [Shift] + [Insert] to jump to the top slot.
4. To add a new song slot, Press [Add Slot], 4th Screen button. Song slots represent a pattern and are displayed as a row on the song mode page.
5. When adding a new slot row, it will
 - Be added directly below the currently selected row.
 - The newly added slot replicates the previously selected row.
 - The new slot row is also automatically selected.
6. To change the pattern on the selected row, Press the [Left], 6th Screen button or [Right], 7th Screen button or hold [Shift] + Turn (Jog). All 255 patterns that are available in a project will be selectable in a song, even if no steps or data has been created in the chosen pattern.
7. More slots can be added to develop the song further and expand its length and duration.

Creating a basic song is a starting point, but a number of additional editing features are also available within Song Mode. Individual tracks can also be re-positioned. Be careful when editing patterns as the song structure and patterns are directly linked and edits can affect each other.

BASIC EDITING OF AN EXISTING SONG

1. Press [Song] to select song mode. The slot and pattern selection bounding box may be displayed green. Also only 1st and 2nd Screen buttons to control play are available in 'green' mode - [Rec] off.
2. Press [Rec] to toggle to editing in 'red' mode. The slot and pattern bounding box will be displayed red. Also all of the screen button options are shown as available in 'red' mode - [Rec] on.
3. Navigate to the slot location desired, Turn (Jog). The location selected is shown with the red bounding box over the slot number and pattern number when editing. Alternatively Press [Up] and [Down] to also navigate through the slots.
4. To delete the currently selected song slot, Press [Delete Slot], 5th Screen button. The selected song slot is deleted and the other slots will move up the order.
5. Press [Add Slot], 4th Screen button to add a new song slot row.
6. The undo command does not restore deleted slots so be careful when editing songs.

NOTES

NOTES

EDITING TRACK CLIPS IN A SONG

1. Press [Song] to select song mode. The step and pattern cursor will be displayed by a green bounding box. Also, only 1st and 2nd screen buttons to control play are available in 'green' mode - [Rec] off.
2. Press [Rec] to toggle editing to 'red' mode. The step and pattern cursor will be displayed by a red bounding box. Also, all of the screen button options are shown as available in 'red' mode - [Rec] on.
3. Navigate to the desired track clip. Turn (Jog) to navigate through the slots or Press [Up] or [Down]. Navigate to the Track by pressing [Left] or [Right]. The selection is shown with the red bounding box over the pattern for the track.
4. To select multiple track clips, Press [Shift] + [Left], [Right], [Up] or [Down]. The red bounding box will encompass all of the selected tracks.
5. To delete selected track clip(s), Press [Delete/Backspace].
6. Press [Copy/Paste] to copy the highlighted and selected track(s).
7. Navigate to the target track clip location. Turn (Jog) to navigate through the slots or Press [Up] or [Down]. Navigate to the Track by pressing [Left] or [Right]. The selection is shown with the red bounding box over the pattern for the track.
8. Press [Shift] + [Copy/Paste] to paste the previously copied selection into the location selected. When pasting multiple tracks the highlighted track location will represent the top left corner of the copied selection of tracks and as such will paste into the adjacent track locations.
9. The copy / paste edits in song mode will also be performed automatically in the pattern itself and reflected back into the same pattern in other slots. Switching to pattern mode will view any edits made. Care must be taken to remember that the song mode and pattern mode are directly linked. Previous edits can be restored by pressing [Undo], 3rd Screen button.

Track 1	Track 2	Track 3	Track 4	Track 5	Track 6	Track 7	Track 8	Step	Pattern
□	□	■	■	■	■	■	■	1	3
□	□	■	■	■	■	■	■	2	4
□	□	■	■	■	■	■	■	3	8
□	□	■	■	■	■	■	■	4	8
□	□	■	■	■	■	■	■	5	2

Adding a slot replicates the current slot on a row below. Also selects the new slot.

Deleting a slot removes the current slot and moves the below slots up in the order.

Track 1	Track 2	Track 3	Track 4	Track 5	Track 6	Track 7	Track 8	Step	Pattern
□	□	■	■	■	■	■	■	1	3
□	□	■	■	■	■	■	■	2	4
□	□	■	■	■	■	■	■	3	8
□	□	■	■	■	■	■	■	4	8

Copy one or more slot tracks

Paste the previously copied tracks to another location.

9.6 Playing Songs and Patterns

Playing songs within song mode performs differently to playing patterns in the pattern view. It is however also possible to play only patterns from within Song mode. The dedicated play button will play a song in song mode and will play the pattern only when in pattern mode.

NOTES

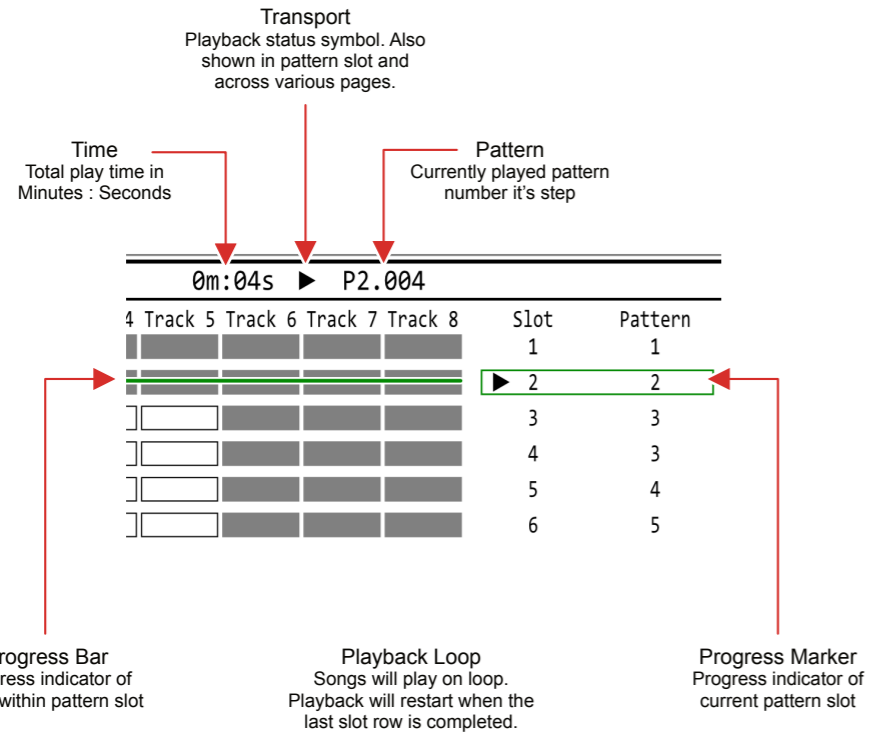

Song Playback Options

Mode	Symbol	Screen Button	State	Button	Description
Song	▶	[Play Song]	Play Song	Play	Will play the song. Changing to pattern mode will play and display patterns in sync with song. Same as pressing [Play]
Song	⏸	[Stop]	Pause	Play	When playing, button will toggle pause. Press again to commence from the start of the paused pattern. Same as pressing [Play]
Song to Pattern	↻	[Play Pattern]	Play Pattern	Shift + Play	Play the currently selected pattern in a loop. Same as pressing [Shift] + [Play]
Pattern to Song	▶	[Continue Song]	Play Song	Shift + Play	Switches from playing pattern to play song from current position. Same as pressing [Shift] + [Play]
Song to Pattern	↻	[Loop Pattern]	Loop Pattern	Shift + Play	Switches from playing song to play and loop pattern from current position. Same as pressing [Shift] + [Play]

NOTES

Playback Behaviour.

Playing a song in song mode can be performed from the dedicated play button or the screen buttons. Songs will play in loop meaning the song will continue to play from the start after the last slot row is completed. Patterns can also be played and looped from song mode. Switching between pattern and song playback is possible using the screen buttons, which change function to reflect the current status.

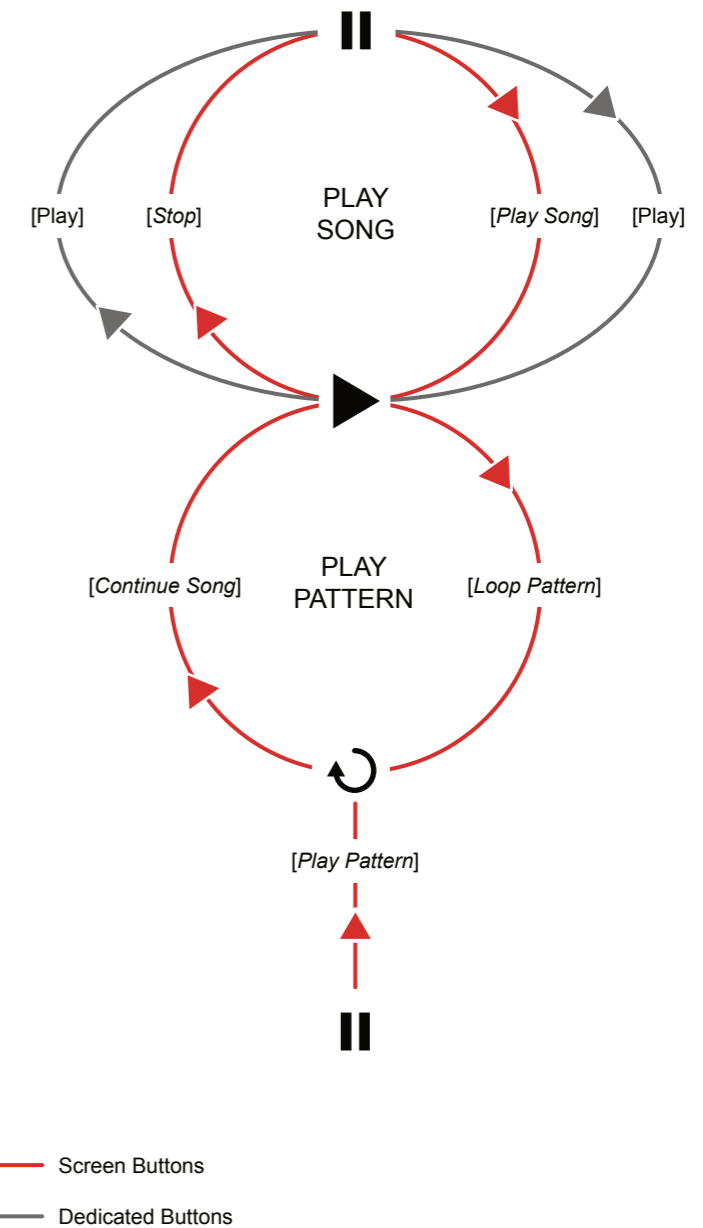

Previewing Tracks in Song Mode

While songs and patterns can be played from within song mode, the ability to preview only individual track clips is possible. This can only be performed in 'Red' [Rec] Mode and with an individual track clip selected.

Track 1	Track 2	Track 3	Track 4	Track 5	Track 6	Track 7	Track 8	Step	Pattern
□	□	■	■	■	■	■	■	1	3
□	□	■	■	■	■	■	■	2	4
□	■	■	■	□	□	■	■	3	8
□	□	■	■	■	■	■	■	4	8

Selected Track Clip.
Example Pattern 8, Track 2

[Shift] + [Play].
Previews the individual track clip

[Shift] + [Preview Track].
Previews the individual track clip



Clip Plays through once fully, unless the [Play] or [Stop], 1st Screen button is pressed to immediately stop.

PREVIEWING A SONG TRACK CLIP

1. Press [Song] to select song mode.
2. Press [Rec] to toggle to editing in 'red' mode. The slot and pattern bounding box will be displayed red. Also all of the screen button options are shown as available in 'red' mode - [Rec] on.
3. Navigate to the track clip location desired, Press [Left], [Right], [Up] and [Down] to also navigate through the slots. Select a single track clip. Multiple selections cannot be previewed.
4. With the track clip selected and highlighted red, Press [Shift] + [Play]. The clip will play once fully or press [Play] to stop playback.
5. Alternatively, with the track clip selected and highlighted red, Press [Shift] + [Preview Track], 1st Screen button. The clip will play once fully or press [Stop], 1st Screen button, to stop playback.

NOTES

NOTES

9.7 Link between Song and Performance Mode

Songs and patterns are integrated and linked to work together. In addition songs work in conjunction with Performance Mode. Performance mode allows live performances and improvisations. Perform is covered in detail in a later section.

Songs can be played in Song Mode which will play through all slots and the patterns assigned. When switching to performance mode the song will continue playing.

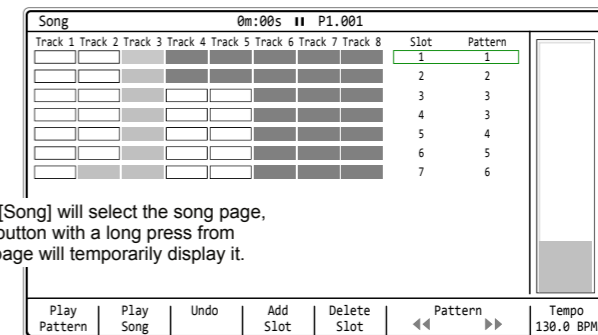

While pressing [Song] will select the song page, holding [Song] button with a long press from within another page will temporarily display it.

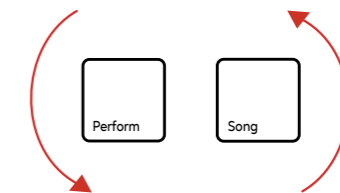

Performance FX		0m:00s		P1.028		C	
Volume	Panning	Tune	Low-pass cutoff	High-pass cutoff	Band-pass cutoff	Delay send	Reverb send
Sample position	Sample end	Sample playback	Volume LFO				
-1	-1	-1	-1	-1	-1	-1	-1
-1	-1	-1	-1	-1	-1	-1	-1
-1	-1	-1	-1	-1	-1	-1	-1
>>>	>>>	/16					
-1	-1	-1	-1	-1	-1	-1	-1
Track 1	Track 2	Track 3	Track 4	Track 5	Track 6	Track 7	Track 8
Patt: 1	Patt: 1	Patt: 1	Patt: 1	Patt: 1	Patt: 1	Patt: 1	Patt: 1

Press [Play] in Performance Mode to play the current pattern as set in the pattern page or set in song mode, whichever is the most current pattern selected. Press [Shift] + [Play] in Performance Mode to play the full song.

↔ The 'Random' symbol in the header of a page will demonstrate that tracks from various patterns can be selected for mixing in performance mode.

10

Master Effects

A number of effects are available in Tracker. Some can be set in the FX1 and FX2 slots and some used in Performance Mode. Also the instrument parameters give access to instrument level effects. This section covers the Master Effects. These are the common effects that are available in the main audio chain and are located in the master page. Effects in the primary audio chain are called insert effects. Effects are not available on an individual track basis so all tracks are routed through the master section. The track mixer is also a page in the master section. An example of an insert effect is the EQ effect. Send effects allow variable amounts of audio to be channelled in parallel to the main mix to the effect. Essentially these are the reverb and delay effects. The main reverb and delay effect settings are accessible from the master page and the send amounts in the global mixer. The three pages including the main mix page, track

mixer page and global mixer functions are available by pressing the [Master] button. Sub pages are contained within, or parameters are available directly from the master page. The master effects have a number of parameters and defined functions. It is always worth remembering that adjustment by ear is usually a more appropriate method when adjusting effect settings. While theoretical numbers and applications are good starting points, there is no better method than to hear how the sound is affected by adjustments as they are applied.

10.1 Effects Overview

Tracker has 8 voices which would represent each of the tracks playback. The common processing of the voices comes together at the master stage where the voices are mixed and the master effects applied. Also the Delay and Reverb 'send' audio is mixed into the main out.

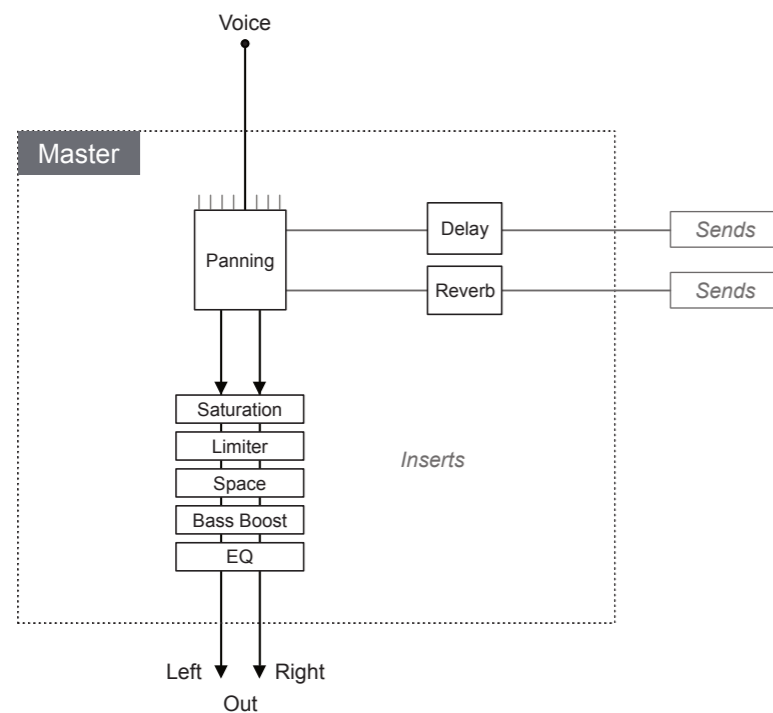

The diagram shown is for illustration purposes and does not constitute an exact or official schematic of Polyend's Tracker circuitry. It does however serve to give an insight into the signal path and identify the six master effects covered in this section.

The reverb and delay send effects can be sent pre-fader or post-fader in the global mixer. This is set in the 'Config' settings. This means the effect is sent before the volume fader or after the volume fader adjustment.

NOTES

10.2 Master Pages

The 6 master effects are located in the master section of Tracker. This is accessible with the [Master] dedicated button which opens to 3 mixer / master pages. The main effects settings are contained within this pages.



Press [Master] to select the Master section.
Each Press of [Master] will cycle through 3 master pages:
Master, Page 1; Track Mixer, Page 2; Global Mixer, Page 3.

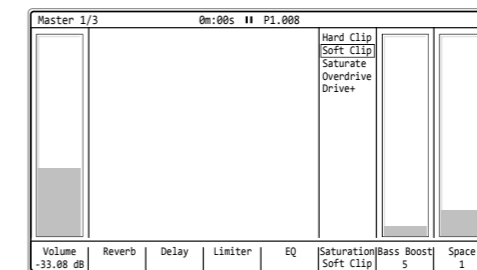

Master - Page 1/3

Gives access to the master output level volume level. Access to the settings pages for the Limiter and EQ are available from the screen buttons. The Saturation, Bass Boost and Space effects have one parameter each and are directly adjustable when selected with (Jog). The two send effect parameter pages are also accessible when using the respective screen buttons.

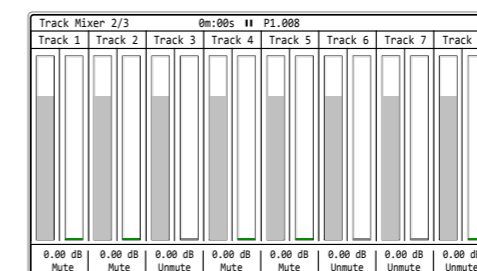

Track Mixer - Page 2/3

Gives access to the individual track levels to allow mixing of the entire song. Hold one or more screen buttons and turn (Jog) to adjust.

Mute and Solo can be set here as well as editing the track names when [Rec] is active.

No effects are provided from this page.

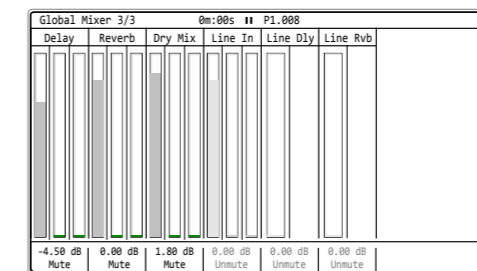

Global Mixer - Page 3/3

The main output delay and reverb sends are visible and can be adjusted. The main dry and wet mix of the audio and effects is also provided. Control for pass through of line inputs. Reverb and delay can be applied to this audio signal. Pre-fader or post-fader are in the configurable in the 'Config' settings.

All settings accessible with the screen buttons

To adjust effect parameters, select the page then use the screen buttons or use [Left] or [Right] to select the parameter. Screen buttons select pages such as delay, reverb etc. Turn (Jog) or Press [Up] or [Down] to change the selected parameter value. Multiple track mixer levels can be adjusted when holding the screen buttons simultaneously.

NOTES

10.3 Master Delay

Delay is one of the two send effects. A send effect basically routes an adjustable amount of audio in parallel to its main signal path and is sent to a common audio effect. In this case delay. This delay affected audio is then returned back to the main audio path. The effect itself is a common function, managing several send / return signals. Any delay parameter adjustments will therefore also affect other send signals. The 'Send / Return' configuration is a common application for delay effects.

What is a delay effect?

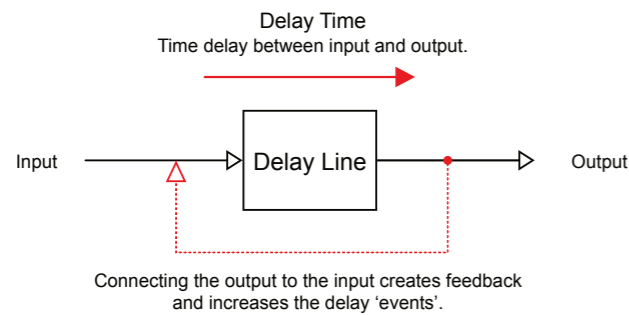

A delay is a common production effect used to delay an incoming signal to the output. While this is a simple principle there are many effects that use delay as a foundation. Some examples are echo (creating defined repeats) and chorus (short delay taps to give a thicker rather than echo style feel) as well as delay types such as ping-pong delay spreading the delay points across the stereo field left to right and slap-back delay emulating old tape delays which are used successfully to thicken vocals.

Delay is a time based effect and synchronisation (or not) with the track tempo should also be considered depending on the output required.

ACCESSING MASTER DELAY PARAMETERS

1. Press [Master] to select master section. Press again if needed, until the 'Master' Page 1/3 is displayed.
2. Press [Delay], 3rd Screen button.
3. The six delay parameters are presented on the master delay page.
4. Press [Back], 8th Screen button to return to the master page.

NOTES

NOTES

Master Delay Page

Accessed via the Master page 1/3 and selected from the screen buttons.

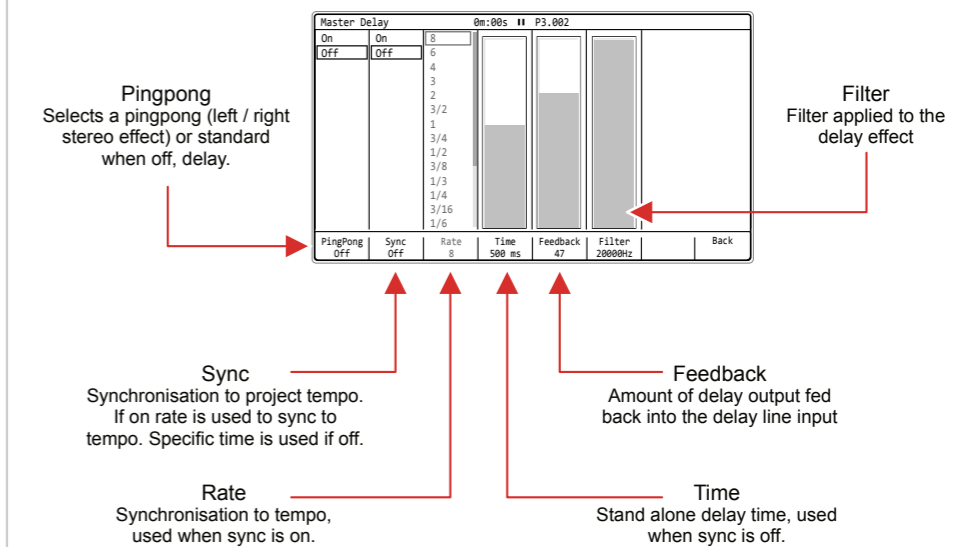

Master Delay Settings.

Option	Range	Description
Pingpong	On, Off	Toggles the pingpong mode on or off. This will set the delays to be generated across the stereo field left to right
Sync	On, Off	Toggles synchronisation to the project tempo on or off. When on, the rate with respect to tempo is used for the delay. When off, the time parameter is used.
Rate	See Rate Table	The rate divider / multiplier, synchronised to project tempo, used for the delay time. Available when sync is set to on.
Time	1 - 3500ms	The time used for the delay. Only available when sync is set to off.
Feedback	0-99	Amount of delay output signal that is fed back into the delay input. This parameter is what increases the number of delays in the audio.
Filter	100Hz - 20000Hz	Applies a filter to the delay and helps shape the sound more appropriately.

Rate Options

8	6	4	3	2	3/2	1	3/4	1/2	3/8
1/3	1/4	3/16	1/6	1/8	1/12	1/16	1/24	1/32	

10.4 Master Reverb

Reverb is the second of the send effects. As stated a send effect routes an adjustable amount of audio in parallel to its main signal path and is sent to a common audio effect. In this case reverb. This reverb affected audio is then returned back to the main audio path. The effect itself is a common function, managing several send / return signals. Any reverb parameter adjustments will therefore also affect other send signals. The 'Send / Return' configuration is a common application for reverb effects.

What is a reverb effect?

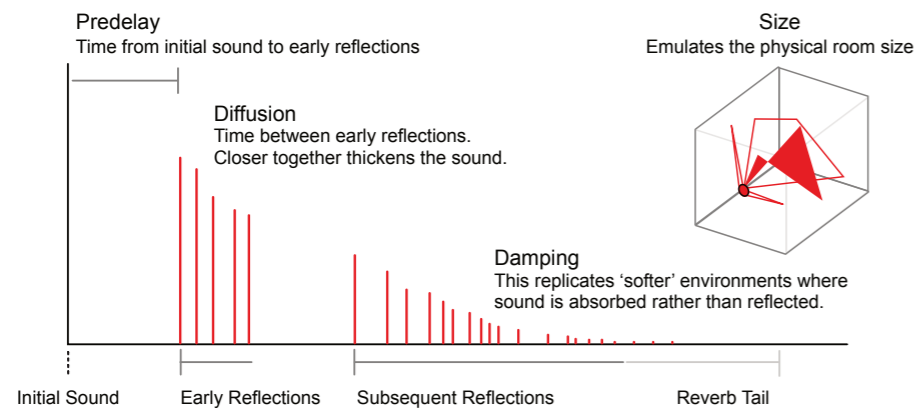

A reverb is a common production effect used to replicate the audio behaviour of spaces. A normal space such as a small or large room will reflect audio differently. Think of how the sound reflects in a large cathedral compared to a small bathroom. The sound will bounce and reflect between the walls and other elements in the room. These reflections arrive at the human ear at different times and different levels. Reverb is an effect that replicates this behaviour.

Reverb parameters mainly focuses on the space / room characteristics.

ACCESSING MASTER REVERB PARAMETERS

1. Press [Master] to select master section. Press again if needed until the 'Master' Page 1/3 is displayed.
2. Press [Reverb], 2nd Screen button.
3. The four reverb parameters are presented on the master reverb page.
4. Press [Back], 8th Screen button to return to the master page.

NOTES

NOTES

Master Reverb Page

Accessed via the Master page 1/3 and selected from the screen buttons.

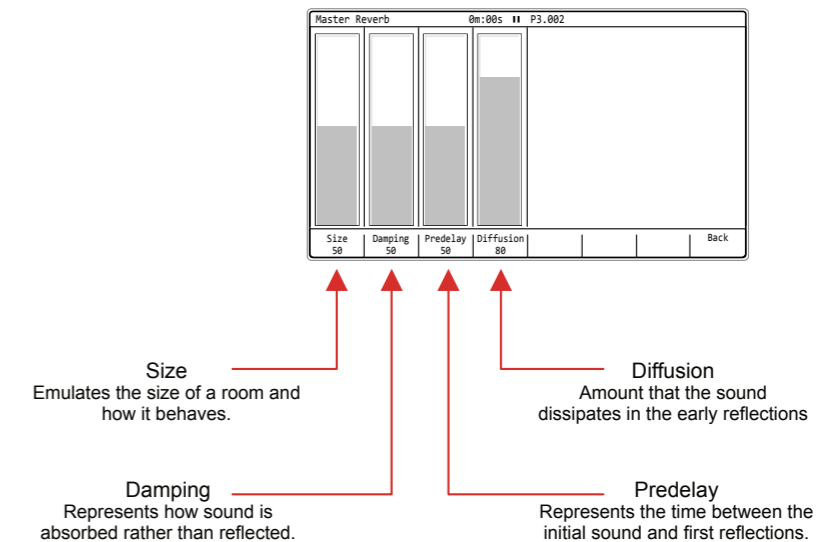

Master Reverb Settings.

Option	Range	Description
Size	0-100	Replicates a physical room size.
Damping	0-100	Sound is reflected with walls, furniture and fittings etc. However it is also absorbed into walls and materials. This emulates the absorbent part of sound in a space.
Pre-delay	0-100	The time from the initial original sound being triggered to the first reflections being heard.
Diffusion	0-100	Diffusion emulates how much sound is dissipated. Essentially this is based on the time period between the early reflections. The wider, the thinner the reverb effect.

10.5 Limiter

Tracker's limiter operates as the first insert effect in the master effect chain. This is not a typical configuration as most applications have a limiter as the last effect in a chain. Insert effects in Tracker route the entire, main audio signal prior to the output.

What is a limiter?

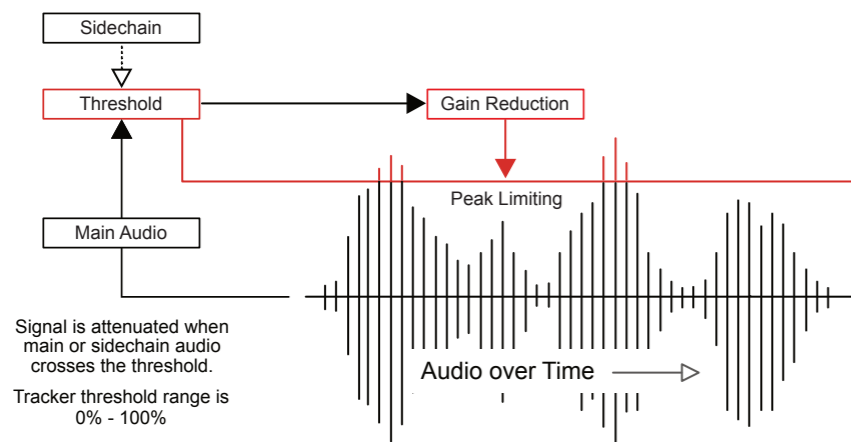

A limiter is normally used at the end of an audio chain and is used to protect the digital integrity by taming signals beyond a threshold, keeping levels within a defined limit and usually avoid digital clipping. Limiters are useful to develop a sounds level and increase the perceived loudness.

Tracker's limiter also has a sidechain function. The Limiter threshold is based on the main audio (sidechain off). Sidechain options will route an alternative audio signal to trigger the gain reduction instead of the main audio. This can be used creatively and triggered by a track or an external audio signal

ACCESSING MASTER LIMITER PARAMETERS

1. Press [Master] to select master section. Press again if needed until the 'Master' Page 1/3 is displayed.
2. Press [Limiter], 5th Screen button.
3. The five limiter parameters are presented on the master limiter page.
4. Press [Back], 8th Screen button to return to the master page.

NOTES

NOTES

Master Limiter Page

Accessed via the Master page 1/3 and selected from the screen buttons. The behaviour of the limiter as extreme or subtle can be set in the 'Config' menu options.

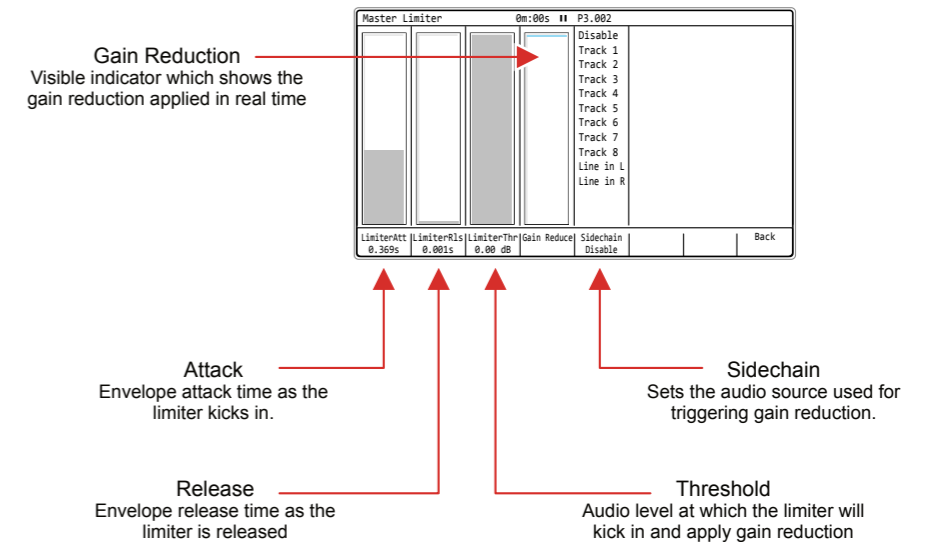

Master Limiter Settings.

Option	Range	Description
Limiter Att	0.001 - 1.000s	Envelope attack time which controls the limiter behaviour as the limiter kicks in.
Limiter Rls	0.001 - 1.000s	Envelope release time which controls the limiter behaviour as the limiter drops out.
Limiter Thr	-Inf dB to 0dB	The threshold level at which gain reduction and hence limiting is applied. Source is based on the audio source - Main or Sidechain.
Gain Reduce		Visual, real time indicator of gain reduction being applied. Does not offer any parameter settings - indication only.
Sidechain	Disable, Track 1-8, Line In L R	Selects the audio signal used to trigger limiting. The normal state is disabled which uses the main audio. Alternatively individual tracks or line in L or R can be selected.

Setting a limiter is an iterative process. Set up the source and fast attack and release then make small incremental adjustments while playing the song, starting with threshold. Once an appropriate gain reduction is reached tweak the attack and gain to further shape the sound.

10.6 Saturation, Space & Bass Boost

Saturation, Space and Bass Boost are simple effects each carrying one parameter that adjusts the amount of effect applied into the main audio out or in the case of saturation, sets the defined preset.

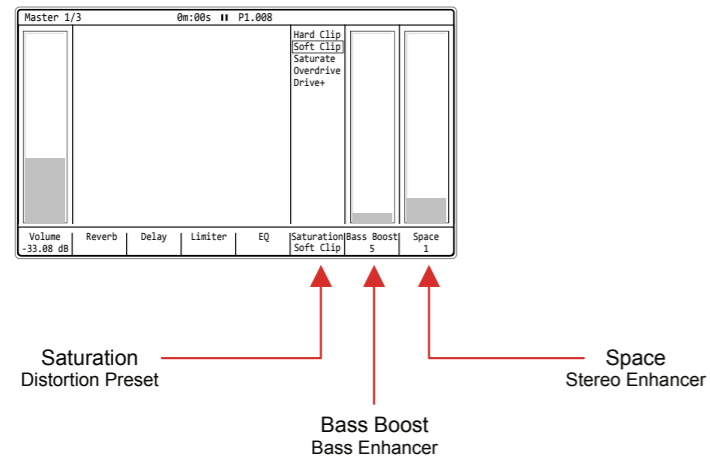

Saturation is the first effect in the entire master chain. This is selects from 5 preset options for subtle distortion. The space option, ranges 0-8 and is a widener enhancing the stereo image. Bass boost has a 0-100% range with represents approx 0-5 dB. This enhances the bass frequencies around 80 Hz, which can be subtle on some material. Both will be applied based on taste so try tweaking and adjusting on different songs to find the sweet spot for the material and track.

ADJUSTING THE BASS BOOST / SPACE PARAMETERS

1. Press [Master] to select master section. Press again if needed until the 'Master' Page 1/3 is displayed.
2. To select the effect:-
 - Press [Saturation], 6th Screen button
 - Press [Bass Boost], 7th Screen button
 - Press [Space], 8th Screen button
 - The (Left) or (Right) buttons also navigate and select.
3. Turn (Jog) or Press [Up] or [Down] to adjust the setting.

NOTES

10.7 EQ

Equalization, also called EQ, is an effect which allows the adjustment of specific frequency bands to shape the sound spectrum. This can adjust the tone and have an audible creative effect for sound design.

What is a EQ?

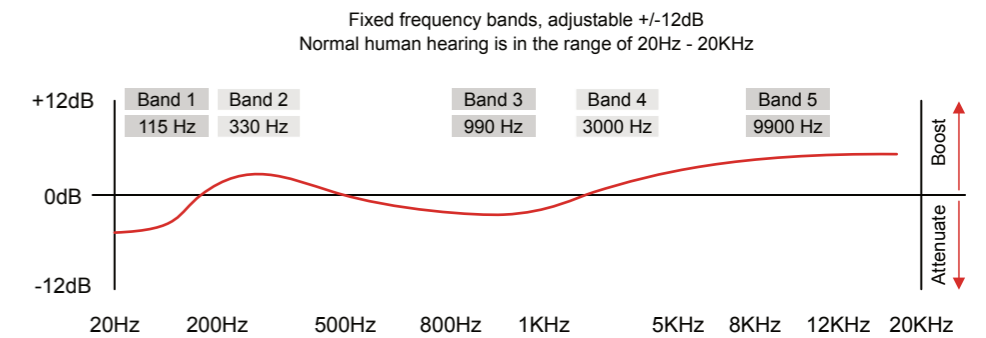

An EQ is set up with a number of frequency bands. Many models have adjustable frequency, width of band and the ability to boost or attenuate at the given frequency. Tracker's EQ is the last master effect in the chain and has 5 fixed frequency bands.

The adjustment is based on a dB Boost or Attenuation with a range of -12dB to +12dB. A setting of 0.00dB across the range means no EQ is applied and the audio will be unaffected.

A normal human hearing range is 20Hz to 20kHz. This is the range an EQ therefore operates with specific ranges affecting sound elements. Some examples are:-

- Vocal sibilance occurs around 3-7kHz. Try cutting at 3kHz or 9.9kHz to de-ess and remove any stand out 'S' elements.
- Mic rumble can be removed around 70-150Hz.
- Boost around 9kHz to give a sound more 'air' and brilliance.
- A cut at 1kHz can help vocals by removing 'honkiness'
- Cut at 300Hz to remove muddiness
- Boost at 115Hz to add warmth.

NOTES

ACCESSING MASTER EQ PARAMETERS

1. Press [Master] to select master section. Press again until the 'Master' Page 1/3 is displayed.
2. Press [EQ], 6th Screen button.
3. The five EQ parameters are presented on the master EQ page.
4. Press [Back], 8th Screen button to return to the master page.

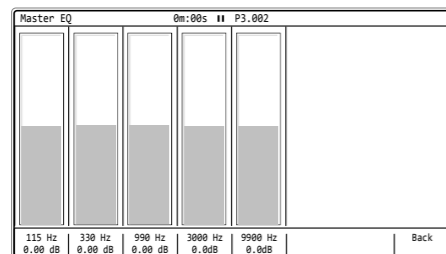

10.8 Effect Config Options

Several options can be set in the 'Config' menu for master effects. The behaviour of the limiter can be changed between extreme and subtle. Also the master mix reverb and delay can be configured to send before / pre the volume level fader or after / post fader.

SETTING THE CONFIG OPTIONS FOR MASTER EFFECTS

1. Press [Config] to open the configuration menu.
2. In the first column, select 'Project Settings'. Use the 1st and 2nd Screen button to navigate. Alternatively use [Left] or [Right] to navigate menus and Turn (Jog) or [Up] or [Down] to select a function.
3. In the 'Project Settings' Sub menu the 'Limiter mode' and the 'Sends mode' can be adjusted. Select from the central sub-menu with the 4th or 5th Screen button.
4. The Limiter options are:
 - Subtle: Will affect how aggressive the envelope attack and release operates. Subtle will give a gentle, transparent style and will be slow in catching fast transients.
 - Extreme: Will provide a more aggressive model. Will catch all of the transients but will also affect the sound adding colour.
5. The Send effects:
 - Pre-fader: Will send the audio to the effect irrespective of the instrument volume. The effected signal will be louder.
 - Post-fader: Will send the audio after it has been adjusted by the instrument volume and therefore ensures the effect is more proportionally consistent with the level, especially when modulated
6. Press [Change], 6th Screen button to change the option.
7. Navigate with the 4th or 5th Screen button and press [Apply], 6th Screen button to accept the option.

11

MIDI

While working with audio has been covered extensively, Tracker also has a set of comprehensive MIDI features. MIDI is the protocol which allows devices to communicate together, for example where one device controls sequencing to send to another synth. A lot of the processes and instructions for audio also apply to MIDI, so for example steps in a pattern can be set to send MIDI rather than trigger an audio sample instrument. MIDI configuration of steps is handled just like an instrument. Tracker therefore can control external gear from its sequencer. In addition external gear can also be set up to control Tracker. A few fundamental things should be considered when working with MIDI. The clock in a multi gear setup will control timing between devices. As such only one main clock should be declared. Also the transport of which device will stop and start the sequencing. These of course are design choices taken

when organising a collection of equipment to work together with MIDI and should be considered at the outset. MIDI in Tracker can be set up through the USB connection or the MIDI interface which uses an adapter cable to convert the 3.5mm connection to standard 5-Pin DIN style MIDI connections. MIDI expands the landscape of sound design when using Tracker in a setup. Audio, controlled by tracker from external devices can also be sampled back into Tracker, making it a perfect fit for the centre piece of a setup.

11.1 MIDI Definitions

To clarify some of the terminology and technology around MIDI with respect to Tracker a summary of key definitions is provided. Tracker uses a TRS to Type B MIDI Adapter. Also MIDI over USB is possible.

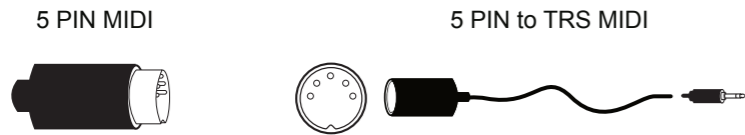

MIDI DIN 24

This is often found for MIDI Out and Thru and enables syncing of classic devices. This uses 0v & 5v messages as sync signals at 24 pulses per quarter note (PPQN). Tracker uses 192 PPQN Internally and can also transmit and receive via USB.

MIDI CC

MIDI Control and Note change messages are used to communicate messages across MIDI with values of 0-127. Control Changes (CC) affect parameter values while note data triggers notes. Tracker has some defined CC Assignments.

NRPN

Non-Registered Parameter Number is part of the MIDI standard. CC and NRPN are technically very similar but NRPN is less well defined in the standards. NRPN uses more data and can give better control.

The term 'primary lead' will refer, in this guide to a device that has the main control responsibility. For example controls the clock and transport and is the central lead. A device which will be controlled by, and follow the primary lead device and which will be subservient by responding to the main control messages will be called a 'secondary follower'.

MIDI DIN 48

This is often found for MIDI Out and Thru and enables syncing of classic devices. This uses 0v & 5v messages as sync signals at 48 pulses per quarter note (PPQN). Tracker uses 192 PPQN Internally and can also transmit and receive via USB.

MSB & LSB

Most Significant Byte and Least Significant Byte. MSB provides the 128 data resolution which is ok for most MIDI applications. More advanced devices use MSB and LSB values increasing resolution to 16,384 steps.

SYSEX

System Exclusive. This is an expansion of the normal MIDI communications set up and is typically used for transferring data such as back ups, patches, presets and firmware updates to and from devices.

MIDI

Musical Instrument Digital Interface. A protocol for communicating between electronic musical gear. Never connect MIDI gear to incompatible DIN signals. Tracker has USB MIDI but also an interface for 5 Pin DIN In and out.

MIDI STANDARDS

While there are MIDI standards defined, many synth developers interpret this in slightly different ways. Its always worth reviewing the documentation with each to fully understand each device level implementation.

SDS

Sample Dump Standard. This is an older transfer protocol used for transferring data to and from devices. This is rarely seen nowadays.

NOTES

NOTES

11.2 MIDI Configuration

A pre-requisite to working with MIDI is to ensure that the configuration settings in the [Config] menu are applied for the desired MIDI gear setup. These will dictate if Tracker leads on functions like clock and transport or if it acts as a secondary follower, responding to control and synchronisation from another primary device control. Also Note and CC behaviour is set.

Menu	Option	Description
MIDI	Clock In	Sets the Tracker clock between the internal generated clock (default) or an external clock received through the USB or MIDI In jack.
MIDI	Clock Out	Sends the Tracker clock output to other devices. Off, USB, MIDI Out jack or USB+MIDI jack options.
MIDI	Transport In	Sets the source of transport control commands, Internal (default), or control from an external device received through the USB or MIDI In jack.
MIDI	Transport Out	Sends Tracker transport control commands to other devices. Set to Off, USB, MIDI Out jack or USB+MIDI jack options.
MIDI	Notes In	Sets the input of how notes are received from an external device. Set to Off, USB, MIDI In jack or USB+MIDI jack options.
MIDI	Notes Input Channel	Sets the MIDI channel for external note inputs. Select All channels or Ch 1-16.
MIDI	MIDI Out	Sets the output routing of MIDI to communicate to other devices. Set to Off, USB, MIDI Out jack or USB+MIDI jack options.
MIDI	CC In	Defines how the CC (control change) input from external devices is handled. Set to Off, USB, MIDI In jack, USB+MIDI In jack.
MIDI	CC In channel	Sets the MIDI channel that is used to receive CC (control change) messages. Select All channels or Ch 1-16.
MIDI	Middle C	Sets Tracker's middle C as C-3, C-4, C-5, C-6. This will calibrate the note ranges to external gear if this does not naturally match.
MIDI	Clock Sync Delay	Latency compensation for incoming clock synchronisation. Options range from -50 to +50 with each unit = 1/250 of pattern step. Leave at the default 0.0 unless there are synchronisation errors.

Velocity can be recorded from an external MIDI controller, but this must be set in the recording options.

Menu	Option	Description
Project	Recording Options	This option sets the recording options for the project. To record velocity from an external controller one of the velocity inclusive options should be selected.

NOTES

The settings in the config menu will depend on:-

- How the devices are connected together? Are the devices connected by USB? Which will transmit and receive MIDI with the MIDI 5 Pin connection using the MIDI Jack adapter?
- Which device will be a primary leader (main controller e.g. main clock) or a secondary follower (will respond to other gear as the lead control e.g. synchronised to another clock)?
- Will MIDI note data (melodies, chords, etc) be communicated?
- Will MIDI CC control change data be communicated (to change parameters like delay level or trigger performance effects)?

ACCESSING THE MIDI CONFIG OPTIONS

1. Press [Config] to open the configuration menu.
2. In the first column, select 'MIDI'. Use the 1st and 2nd Screen button to navigate. Alternatively use [Left] or [Right] to navigate menus and Turn (Jog) or [Up] or [Down] to select a function.
3. The 'MIDI' Options will be available in the central menu window. Use the 4th and 5th Screen button to navigate. Alternatively use [Left] or [Right] to navigate menus and Turn (Jog) or [Up] or [Down] to select a function.
4. Press [Change], 6th Screen button to edit the option that is highlighted.
5. Use the 4th and 5th Screen button to navigate to the desired parameter setting. Alternatively use [Left] or [Right] to navigate menus and Turn (Jog) or [Up] or [Down] to select a function.
6. Press [Apply], 6th Screen button to confirm the option that is highlighted.

NOTES

11.3 Typical MIDI Configurations

There are many configurations that can be set up with MIDI gear. Some are complex and involve multiple devices while a simple set up can have two devices communicating. Some typical examples are shown.

Example Configuration 1: Tracker as the primary lead.

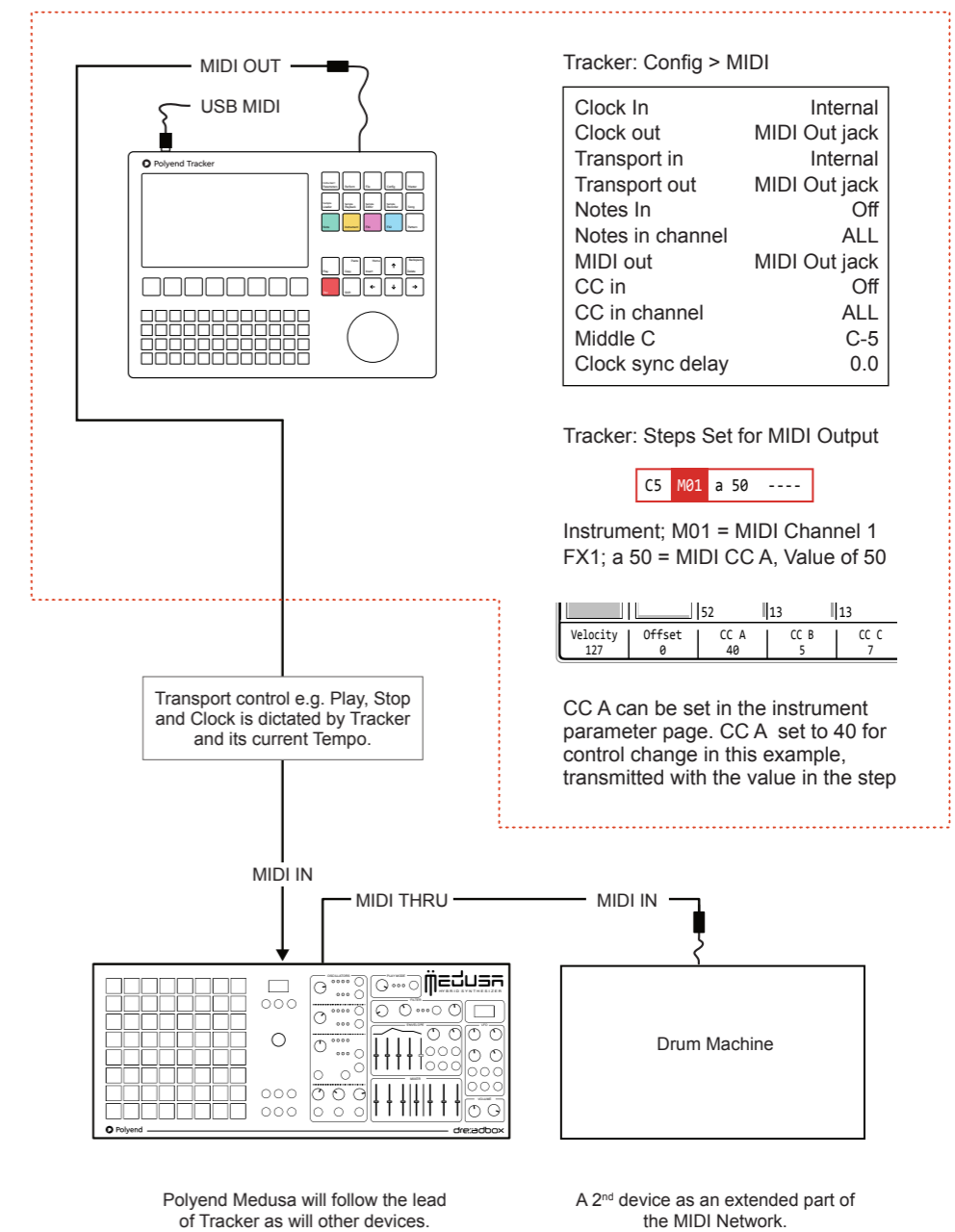

Devices should be configured to receive clock and transport and the MIDI Channel which Tracker communicates, for example, Channel 1. CC 40 In Medusa represents the Filter Cutoff frequency in this example each step in Tracker will set the filter cutoff.

The ability to connect to a PC or Mac via a MIDI connection is possible, which can allow software synths and plug-ins to be controlled by Tracker. Tracker will need a hub or will need to be powered by the PC / Mac as the USB connection is the source of power for Tracker.

Example Configuration 2: Tracker in / out with Ableton Live.

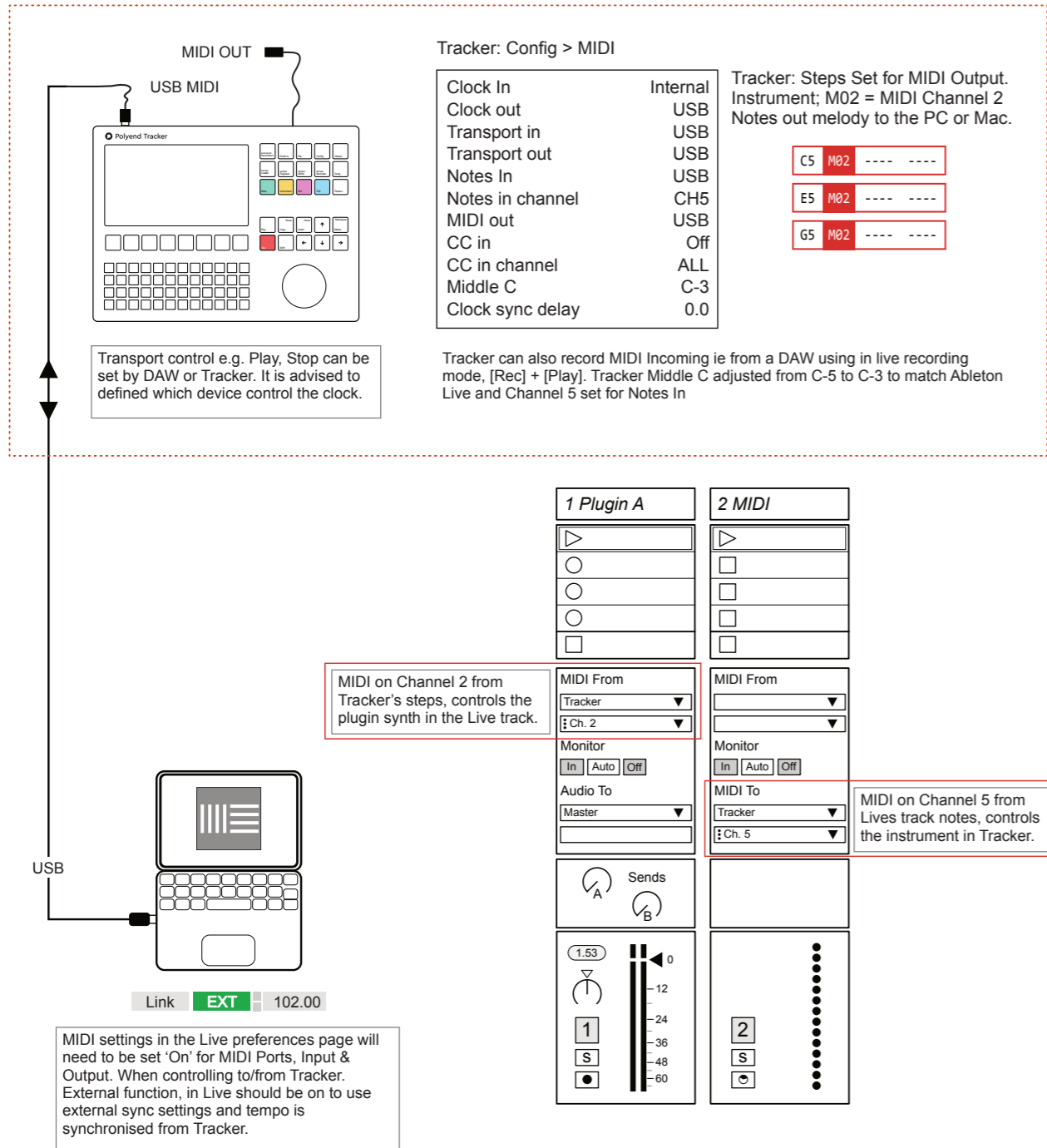

NOTES

An external device, keyboard or drum pads can be connected to control Tracker by MIDI either by USB or via the 5 Pin MIDI dongle. Notes can be played or recorded and CC messages controlling assigned parameters.

Example Configuration 1: Tracker as the secondary follower.

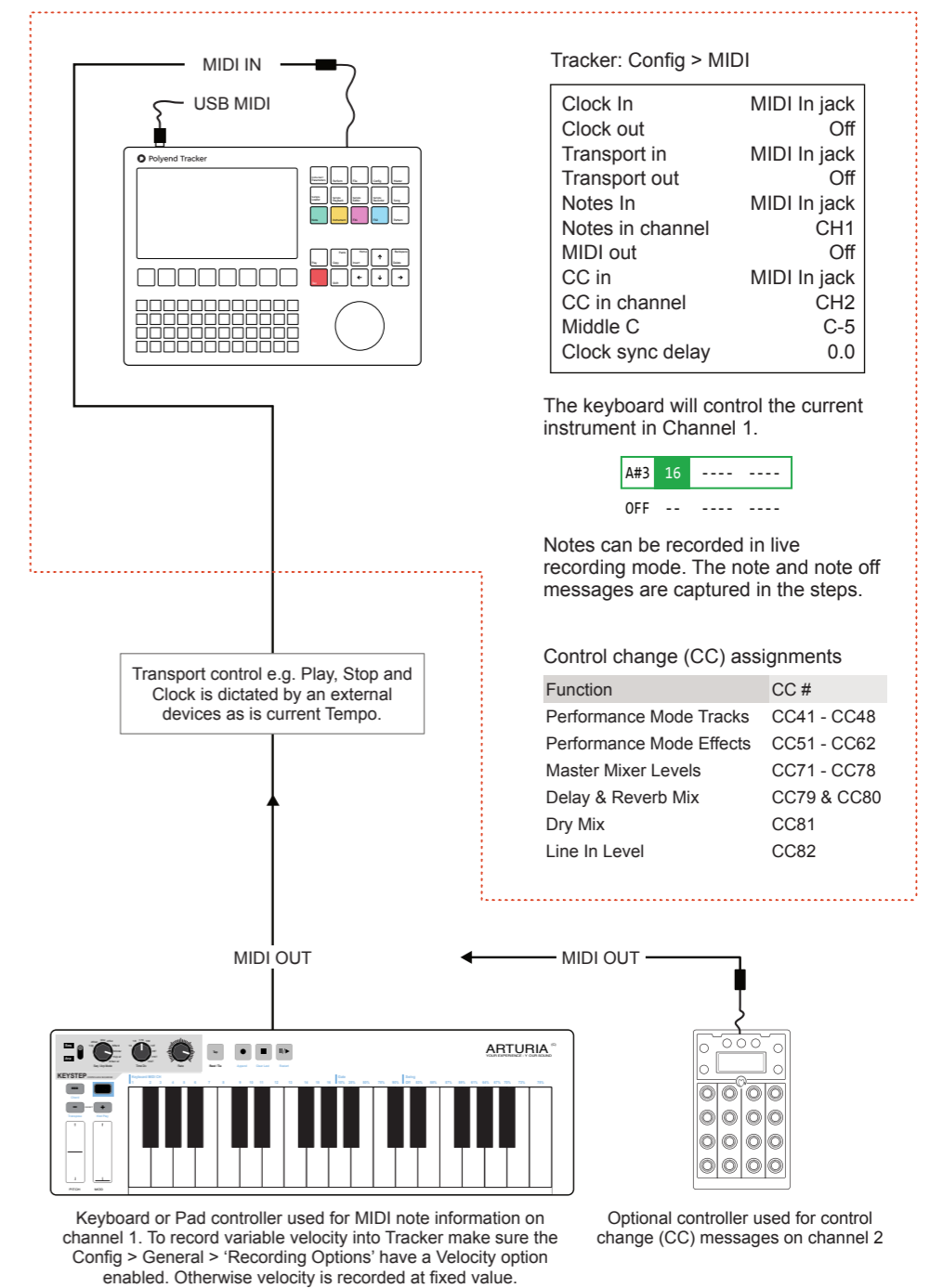

11.4 MIDI Instrument Overview

Tracker has a series of MIDI Instruments that can be assigned to steps in a pattern. MIDI is defined per step, not per track, so MIDI and Audio instruments can reside on the same track in the same pattern. A MIDI instrument essentially defines the MIDI channel on which to transmit data out and also gives access to the instruments MIDI parameters.

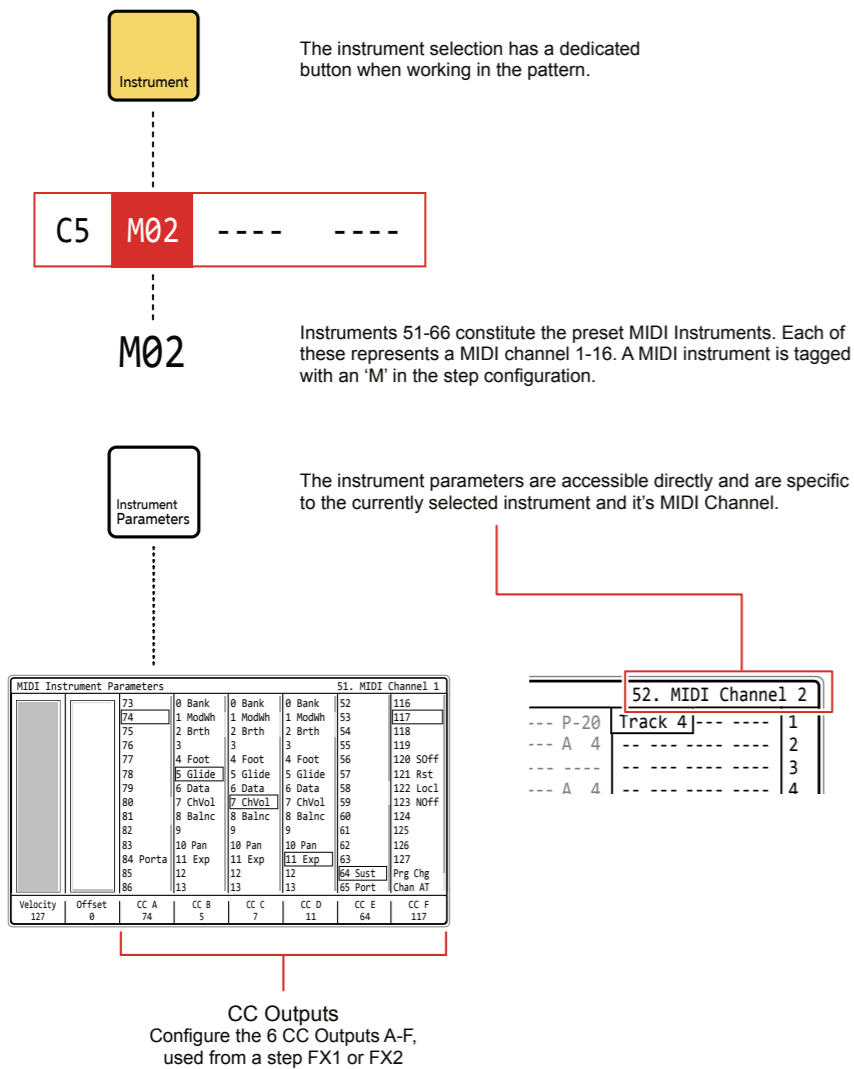

NOTES

NOTES

The Instrument parameters will reflect the MIDI output options available when selecting a step with a MIDI instrument configured. The Note is set in the step and will be sent on the channel defined in the MIDI instrument. The default velocity can also be set for MIDI out.

The same general process is followed when working with MIDI steps as with audio steps. More details are covered in a prior section.

CREATING A MIDI NOTE OUTPUT STEP

1. Press [Pattern] to select the Pattern Mode page.
2. Select the target step to edit. Use [Up], [Down] or Turn (Jog) to scroll top to bottom. Press [Left], [Right] to select a track. Example Row 1 of Track 1. The step should be highlighted with the green bounding box.
3. Press [Rec] to switch to recording mode. The step bounding box will turn red and allow editing of the step.
4. Note: Hold [Note] + [PAD] to set a note for the step. Also with the note already selected, Turn (Jog) to change its value. Long Press [Note] alone will set an empty step to default note i.e. C0.
5. Instrument: Hold [Instrument] + Turn (Jog) to change to an instrument from the 51 to 61 list. Each one will represent a MIDI channel where the step messages will be transmitted. The Instrument will be indicated with an 'M' in the instrument slot for the step.

Instrument #	Name	Step Tag	MIDI Channel
51	MIDI Channel 1	M01	1
52	MIDI Channel 2	M02	2
53	MIDI Channel 3	M03	3
54	MIDI Channel 4	M04	4
55	MIDI Channel 5	M05	5
56	MIDI Channel 6	M06	6
57	MIDI Channel 7	M07	7
58	MIDI Channel 8	M08	8
59	MIDI Channel 9	M09	9
60	MIDI Channel 10	M10	10
61	MIDI Channel 11	M11	11
62	MIDI Channel 12	M12	12
63	MIDI Channel 13	M13	13
64	MIDI Channel 14	M14	14
65	MIDI Channel 15	M15	15
66	MIDI Channel 16	M16	16

The default velocity to send out can be applied as well as MIDI Latency compensation in the Offset parameter

This illustration shows several MIDI instruments set for MIDI Channel 2. The notes values will be sent on the defined channel to a connected device such as another synth or DAW. MIDI Out would need to be set correctly in the Config > MIDI parameters to transmit the note values over MIDI.

The MIDI transmitted will be based on the project tempo. Also remember that tempo FX can be applied to steps which would also affect the MIDI output timing.

11.5 Handling MIDI Velocity

The velocity of notes triggered by steps is set by default in the MIDI instrument parameter page. This ranges from 0-127. An FX1 or FX2, 'V' Step effect can also be applied which will define the velocity specifically for the step. External gear will receive the note message with the defined velocity transmitted.

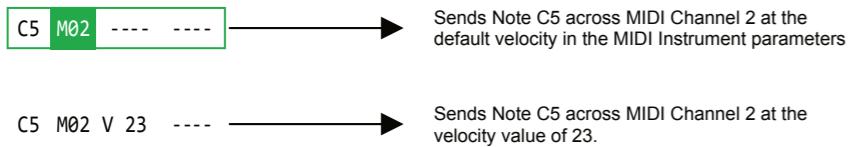

The FX value in Tracker is based on a range of 0-100, however most devices and DAWs use a velocity range of 0-127. Bear this in mind when applying and recording FX velocity

Recording of note data can be performed from external gear into Tracker in Live Recording mode using [Rec] + [Play]. To be able to record velocity, the Config > General > 'Recording Options' would need a velocity option to be set i.e. 3 or 4 from the list below. The options are:-

1. Only Notes: Records only quantized notes into a pattern.
2. Microtiming: Records notes with microtiming into a pattern.
3. Velocity: Records quantized notes and velocity into a pattern.
4. Microtiming + Velocity: Records notes with microtiming and velocity into a pattern.

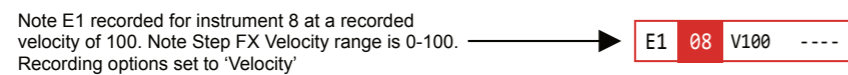
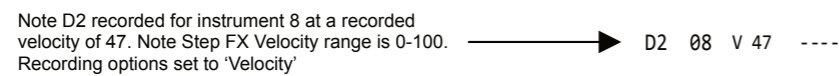

NOTES

NOTES

11.6 MIDI CC Out

Control change messages, also called CC, can be sent from Tracker on a step by step basis. While note message will trigger the notes on other gear, CC initiates a parameter change, for example to adjust Pan or Filter Cutoff on another device. These would need to be matched at Tracker end to align to the parameter on the external device. Six CC parameter slots A-F exist in tracker that can be allocated a CC and then used in FX1 or FX2 of a step.

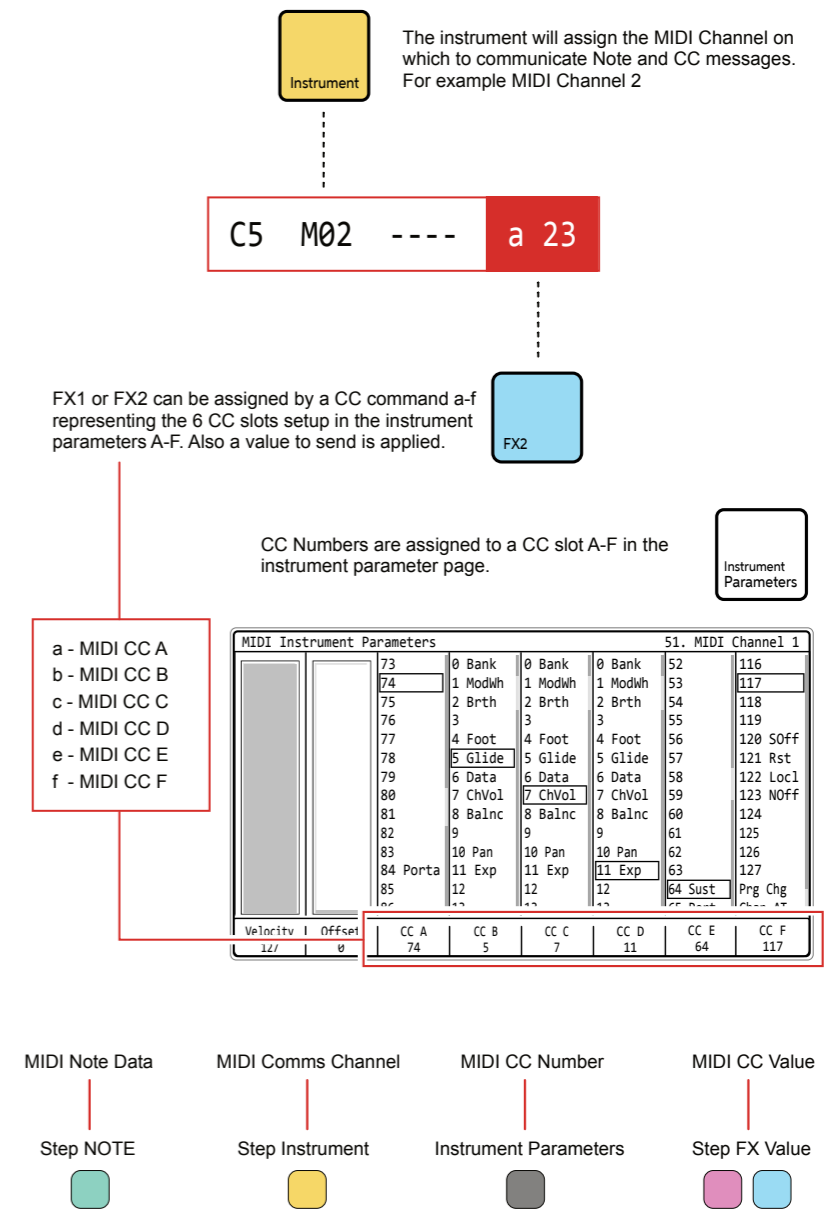

This illustration shows that Control Change 74 is assigned to CC A, which in turn is assigned as FX2 with a value of 23. If, for example, Elektron Digitakt is the receiving device, this step will send a message to control the filter cutoff.

The MIDI CC outputs in the Instrument Parameters list follows MIDI standards. Many of the CC's are undefined. Check the MIDI configuration for any connected devices to know what CC will affect which parameter. This list is available for each of the 6 CC Assignments A - F. Also the Program Change 128, Channel Aftertouch 129 and Polyphonic Aftertouch 130 can also be configured here.

CC #	Function	CC #	Function	CC #	Function	CC #	Function
0	Bank (MSB)	32	Bank (LSB)	64	Sustain	96	Data Increment +
1	Mod Wheel (MSB)	33	Mod Wheel (LSB)	65	Portamento	97	Data decrement -
2	Breath Control (MSB)	34	Breath Control (LSB)	66	Sostenuto	98	NRPN LSB
3		35		67	Soft Pedal	99	NRPN MSB
4	Foot Pedal (MSB)	36	Foot Pedal (LSB)	68	Legato	100	RPN LSB
5	Glide (MSB) Portamento Rate	37	Glide (LSB) Portamento Rate	69	Hold 2	101	RPN MSB
6	Data Entry (MSB)	38	Data Entry (LSB)	70		102	
7	Channel Volume (MSB)	39	Channel Volume (LSB)	71		103	
8	L/R Balance (MSB)	40	L/R Balance (LSB)	72		104	
9		41		73		105	
10	Pan (MSB)	42	Pan (LSB)	74		106	
11	Expression Pedal (MSB)	43	Expression Pedal (LSB)	75		107	
12		44		76		108	
13		45		77		109	
14		46		78		110	
15		47		79		111	
16		48		80		112	
17		49		81		113	
18		50		82		114	
19		51		83		115	
20		52		84	Portamento Amount	116	
21		53		85		117	
22		54		86		118	
23		55		87		119	
24		56		88	High Definition Velocity	120	All sound off
25		57		89		121	Reset all
26		58		90		122	Local On / Off
27		59		91		123	All notes off
28		60		92		124	
29		61		93		125	
30		62		94		126	
31		63		95		127	

NOTES

CREATING A MIDI CC OUTPUT STEP

1. Ensure the Config > MIDI settings are set to send MIDI.
2. Press [Pattern] to select the Pattern Mode page.
3. Select the target step to edit. Use [Up], [Down] or Turn (Jog) to scroll top to bottom. Press [Left], [Right] to select a track. Example Row 1 of Track 1. The step should be highlighted with the green bounding box.
4. Press [Rec] to switch to recording mode. The step bounding box will turn red and allow editing of the step.
5. Hold [Instrument] + Turn (Jog) to select a MIDI instrument from the 51 to 61 part of the list. Each one will represent a MIDI channel where the step messages will be transmitted. The Instrument will be indicated with an 'M' in the instrument slot for the step. Example M01.
6. Hold [FX1] or [FX2] + Turn (Jog) to set a CC for the step. This will be one of the 6 options a-f. The selected option will show as a lower case letter in the step FX slot. Example: a MIDI CC A.
7. With the FX selected, Turn (Jog) to set its CC value. A series of steps could for example be filled with a ramp up of values. This can be changed later. Example: Set to 50.
8. Press [Instrument Parameters] to select the MIDI configuration.
9. Select a CC Slot that matches the FX selection - Example, Press [CC A], 3rd Screen button. Any other CC A - CC F can be selected to match up the the FX setting.
10. Press [Up] or [Down] or Turn (Jog) to scroll the CC parameter lists. Highlight with the bounding box the CC number to assign. This would typically be based on the MIDI CC configuration on a receiving device. Example: CC 74 is Filter Cutoff on Elektron's Digitakt.
11. In this example, CC Number 74 will transmit a CC value of 50 over MIDI Channel 1 when the selected step is triggered.

11.7 MIDI CC In

Control change messages can be received by Tracker. The CC In would need to be set in the Config > MIDI menu along with the CC In channel for the MIDI channel. The MIDI CC Mapping within Tracker has a set of pre-defined destinations for CC messages.

CC #	Function	CC #	Function
41	Performance Effect Track 1 Pattern Select	71	Master - Track Mixer Track 1 Volume Level
42	Performance Effect Track 2 Pattern Select	72	Master - Track Mixer Track 2 Volume Level
43	Performance Effect Track 3 Pattern Select	73	Master - Track Mixer Track 3 Volume Level
44	Performance Effect Track 4 Pattern Select	74	Master - Track Mixer Track 4 Volume Level
45	Performance Effect Track 5 Pattern Select	75	Master - Track Mixer Track 5 Volume Level
46	Performance Effect Track 6 Pattern Select	76	Master - Track Mixer Track 6 Volume Level
47	Performance Effect Track 7 Pattern Select	77	Master - Track Mixer Track 7 Volume Level
48	Performance Effect Track 8 Pattern Select	78	Master - Track Mixer Track 8 Volume Level
51	Performance Effect Slot 1 Value - Top Row	79	Master - Global Mixer Delay Mix
52	Performance Effect Slot 2 Value - Top Row	80	Master - Global Mixer Reverb Mix
53	Performance Effect Slot 3 Value - Top Row	81	Master - Global Mixer Dry Mix
54	Performance Effect Slot 4 Value - Top Row	82	Master - Global Mixer Line Input
55	Performance Effect Slot 5 Value - Top Row		
56	Performance Effect Slot 6 Value - Top Row		
57	Performance Effect Slot 7 Value - Top Row		
58	Performance Effect Slot 8 Value - Top Row		
59	Performance Effect Slot 9 - Top Row		
60	Performance Effect Slot 10 Value - Top Row		
61	Performance Effect Slot 11 Value - Top Row		
62	Performance Effect Slot 12 Value - Top Row		

NOTES

11.8 Program Change

Tracker has the ability to send program change messages. These are MIDI standard messages which trigger a change to the current 'program' of an external device by switching presets or configurations. This of course will be dependant on the program / bank / preset structure and operation of the receiving device. Often synths use banks and presets so the behaviour of the device from a program change may vary.

Program change is configured as a CC parameter using number 129.

Example

Pattern 1

Track 3 Track 4

D6 03 ---- D6 03 ----

D4 04 ---- **D6 M01---- a 01**

D4 04 ---- C 50 D6 03 ----

D4 04 ---- D6 03 ---- V 65

D6 03 ---- D6 03 ----

D4 04 ---- -- M01---- a 02

D4 04 ---- C 50 D6 03 ----

D4 04 ---- -- M01m 50 a 03

MIDI Channel 1, with a Program Change, 129 assigned to CC A. The value will trigger the program selection, in this example 01.

MIDI Channel 1, with a Program Change, 129 assigned to CC A. The value will trigger the program selection, in this example 02.

A Program Change is activated slightly ahead of the note. However it may be better to trigger the program change on a step prior to the note step or at the end of a previous pattern sequence and use micro move 'm' to adjust the timing.

Pattern 2

Track 3 Track 4

D6 03 ---- D6 M01----

D4 04 ---- E6 03 ---- V 50

D4 04 ---- C 50 G6 M01----

D4 04 ---- D6 03 ---- V 65

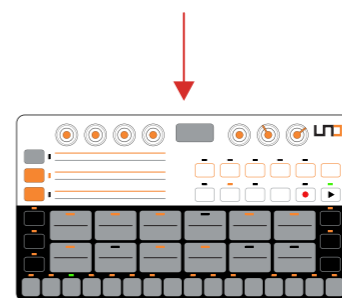

The receiving device may have a configuration that is not an exact match. For example a program may start at 1 rather than 0. The offset may need to be taken into account in the Tracker step program change message.

NOTES

11.9 MIDI Synthesizer

The MIDI synthesizer mode is a feature that allows integration when controlling Tracker from an external MIDI device and by controlling up to 8 voices across MIDI. Tracker will operate as a secondary follower to an external controller which will be able to play and control Trackers instruments. This also brings a tight integration between Tracker and Polyend Play, where the MIDI CC is pre-mapped.

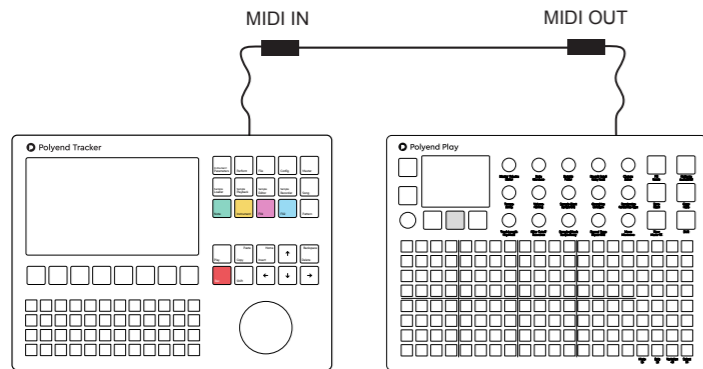

Tracker:

Config > MIDI

Clock In	MIDI In jack
Clock out	Off
Transport in	MIDI In jack
Transport out	Off
Notes In	MIDI In jack
Notes in channel	CH1
MIDI out	Off
CC in	MIDI In jack
CC in channel	CH1
Middle C	C-5
Clock sync delay	0.0

Play:

Menu > MIDI > CC Mapping > Jack Channel 1

Choose: Set Values for Polyend Tracker

The rotary controls in play will be automatically mapped to have full integrated over MIDI CC with Trackers selected instruments. Play can control Tracker with the pads.

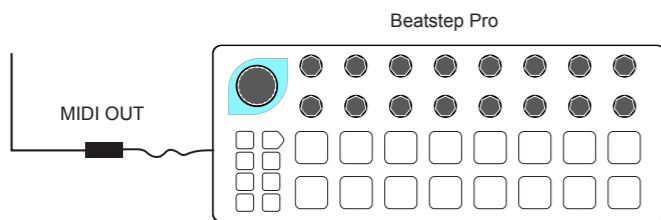

Other MIDI Devices can be used with Trackers MIDI Synthesizer mode to control the instruments.

NOTES

NOTES

While integration with Polyend Play is a build in feature for mapping Play's controls, other MIDI controllers can also be used in Synthesiser Mode.

Synthesizer Mode

Select [Instrument Parameters] page 1/2.
Screen Button [More] then Press [Instrument Synthesizer]

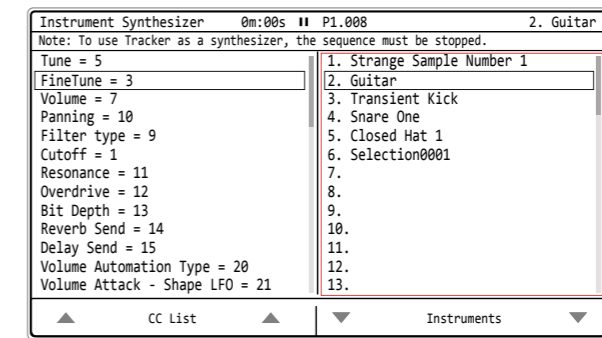

The left window will display, as a reference, the Tracker parameter MIDI CC numbers.

The right window will allow selection of the instrument to control. The instrument selected will be shown in the top bar.

Notes on using MIDI Synthesiser Mode:-

- The external device must be configured to match the MIDI Synthesizer CC controls and general Tracker MIDI configuration, i.e. Channel etc.
- Tracker's sequencer must be stopped to use as a MIDI synthesizer.
- The Synthesizer mode page does not have to be displayed to operate in this mode. The last selected instrument will be the one used for the synthesizer control from an external controller.

NOTES

NOTES

SETTING UP A MIDI SYNTHESIZER

1. Ensure the external device is configured to set MIDI CC as per the Tracker CC assignments in the MIDI Synthesizer page. Also that the MIDI configuration is matched, for example same MIDI channel.
2. Connect the external controller to Tracker, for example using the MIDI In connection and a MIDI cable between devices. Tracker uses a MIDI dongle to convert between MIDI 5 Pin DIN and Mini Jack.
3. To get the reference of CC configurations set up as default for Tracker, Press [Instrument Parameters], select Screen Buttons [More], then [Instrument Synthesizer]. The CC's are displayed in the left window as a reference.
4. To select an instrument as the destination target from the MIDI controller and as the synthesizer instrument, scroll the right window to select the desired instrument. This is also displayed in the top row.
5. The lists can be scrolled with the screen buttons. If the window is selected, highlighted red, the [Up] and [Down] Buttons or the (Jog) wheel will scroll the list.
6. The instrument parameters will adjust when controlled by the external MIDI controller. The changes are animated real time on the instrument parameter displays.

Synthesizer Mode - MIDI CC Configurations

CC #	Function	CC #	Function
5	Tune	83	Cutoff Automation Type
3	Finetune	84	Cutoff - Attack - Shape LFO
7	Volume	85	Cutoff - Decay - Speed LFO
9	Filter Type	86	Cutoff Sustain
1	Cutoff	87	Cutoff Release
11	Resonance	88	Cutoff Amount
12	Overdrive	102	Wavetable Position Automation Type
13	Bit Depth	103	Wavetable Position - Attack - Shape LFO
14	Reverb Send	104	Wavetable Position - Decay - Speed LFO
15	Delay Send	105	Wavetable Position Sustain
20	Volume Automation Type	106	Wavetable Position Release
21	Volume - Attack - Shape LFO	107	Wavetable Position Amount
22	Volume - Decay - Speed LFO	108	Granular Position Automation Type
23	Volume Sustain	109	Granular Position - Attack - Shape LFO
24	Volume Release	110	Granular Position - Decay - Speed LFO
25	Volume Amount	111	Granular Position Sustain
26	Panning Automation Type	112	Granular Position Release
27	Panning - Attack - Shape LFO	113	Granular Position Amount
28	Panning - Decay - Speed LFO	114	Finetune Automation Type
29	Panning Sustain	115	Finetune - Attack - Shape LFO
30	Panning Release	116	Finetune - Decay - Speed LFO
31	Panning Amount	117	Finetune Sustain
		118	Finetune Release

12

Performance Mode

Performance mode is a special Tracker feature which creates an environment aimed at live and real-time performances. Ideal when playing a live gig or improvising and showing off skills of live remixing, performing and on-the-fly creativity. These variations and 'on the fly' changes bring fun and challenge in a live performance environment and expand the creativity in using Tracker. Perform mode can be accessed directly by the dedication function button. The perform page has 12 effect slots. Think of the performance effects as presets where a defined offset from the default parameter value can be applied either momentarily or as a fixed change. Up to 21 effects are available for loading into the 12 available slots. The effect values are then triggered by using the pad grid, where each column of pads relates to each of the 12 effects, giving 4 value options represented by pad rows per effect. These can be applied

when playing patterns or a complete song. Muting can also be managed for tracks in perform mode. Track patterns can be remixed and combined with the performance effects and also along with instrument adjustments which can offer up a comprehensive base for live performance. A dedicated 'top row' of values can also be controlled externally using MIDI. This MIDI option can also be used to control the effect values and the track pattern selection. The performance template by default is saved globally. However this can be set in the 'Config' menu to be saved on a per project basis. Perform brings a different dimension to Tracker, taking the desktop 'programming' of songs or patterns into a more live performance and improvisation environment.

12.1 Performance Mode Overview

Performance mode allows real time improvisation control over tracks, patterns and songs adding variation and interest when playing live. This is normally handled in the 'Perform' page although MIDI Input can also be set to control the performance parameters.



Performance Mode
Press [Perform] to select the performance mode screen, Edit parameters and configure the effects in record mode, press [Rec]. It is possible to cycle between pattern and song pages while performance mode is active.

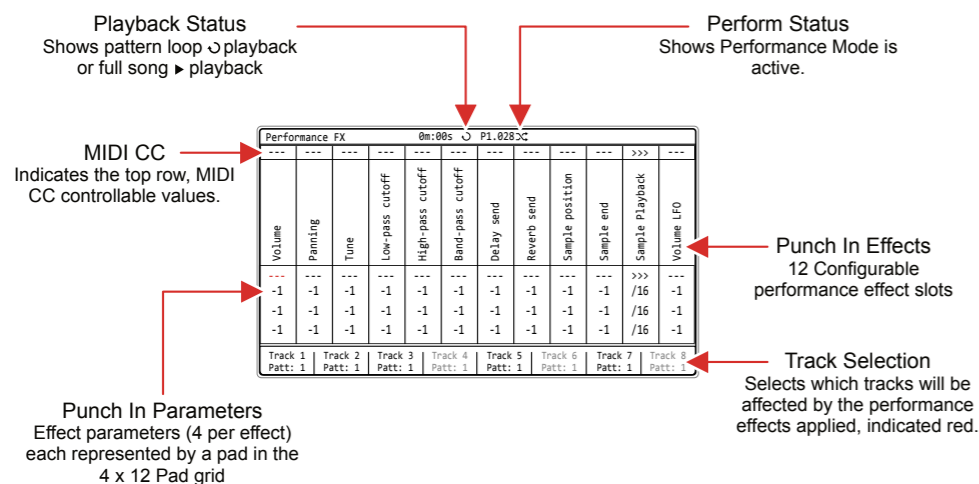

Pad Grid
Each pad represents the turning On or Off of the value defined for the 12 effects. The effect values are configurable with row 1, by default set to off (- -).

...	>>>	...
-1	-1	-1	-1	-1	-1	-1	-1	-1	-1	/16	-1
-1	-1	-1	-1	-1	-1	-1	-1	-1	-1	/16	-1
-1	-1	-1	-1	-1	-1	-1	-1	-1	-1	/16	-1

Selected effects are indicated green or red (if editing) on the tracker screen and the respective pad is lit.

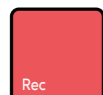

REC Mode
Press [Rec] to edit the perform configuration. The selections will be indicated red as will the effect selection bounding box. Effects can be configured and the values edited in REC mode of Perform.

...
Vol:une
-1
-1
-1

NOTES

NOTES

12.2 Performing - Quick Start

Assuming the effects are set up, values in place then real-time improvisations can be performed. Think of performance effects as applying parameter value variations as an offset from the current setting.

PERFORMING LIVE WITH THE PERFORMANCE EFFECTS

1. Press [Perform] to select the Performance Mode page.
2. Press [Track 1] - [Track 8], screen buttons to select for applying effects on (red) or off. Only the selected, red lit tracks will be affected by the triggered performance effects.
3. Press [Play] to play a pattern or [Shift] + [Play] to play a song, also toggles between song and pattern play. The display header will show the pattern or song playback symbol. Also the perform mode symbol will be displayed.

Pattern Play 0m:00s ↻ P1.028

Song Play 0m:00s ▶ P1.028

4. To punch in an effect, Press [PAD]. The effect is retained once pressed. The Pad column represents each of the 12 loaded effects. The Pad row represents the effect value setting. A default series of effects will be in place, example column 1, Volume.
5. To clear the effect, Press [PAD] for the effect, row 1. The Pad row 1 is reserved for restoring the default, i.e. effect off.
6. To apply a temporary effect, Hold [PAD] + Turn (Jog) - when NOT in [Rec] mode, i.e. parameters are green. The effect value will be applied while the pad is held and will revert to the default when the pad is released.
7. The effect will apply an offset to the current value of the parameter affected. The value will be as stated in the parameter row. For example, set pitch offsets for lead or bass tracks.
8. To mute / unmute tracks, Hold [Shift] + Press [Track 1] - [Track 8], Screen buttons.
9. Press [Instrument Parameters] and [Perform] to toggle between audio instruments and perform to offer more variations while still performing.

12.3 Selecting Tracks

Effects triggered in performance mode will only affect selected tracks. These are selected using the screen buttons and will be indicated in red. Tracks can also be muted from within the perform page.

SELECTING TRACKS TO APPLY PERFORMANCE EFFECTS

1. Press [Perform] to select the Performance Mode page.
2. Press [Track 1] to [Track 8], these are buttons that are represented by the 8 screen buttons. This will toggle selection on or off.
3. A selected track will be lit red in the screen button label, which means any performance effect triggered will apply to only the selected tracks. Tracks showing unlit will be audible but the effect will not be applied.

MUTING TRACKS IN THE PERFORM PAGE

1. Press [Perform] to select the Performance Mode page.
2. Press [Shift] + [Track 1] to [Track 8], these are buttoned represented by the 8 screen buttons. This will toggle mute on or off.
3. A muted track will be labelled to reflect the state when pressing [Shift]. In the normal display a muted track screen button text label is shown in black, while text for an unmuted, audible track is displayed in white.

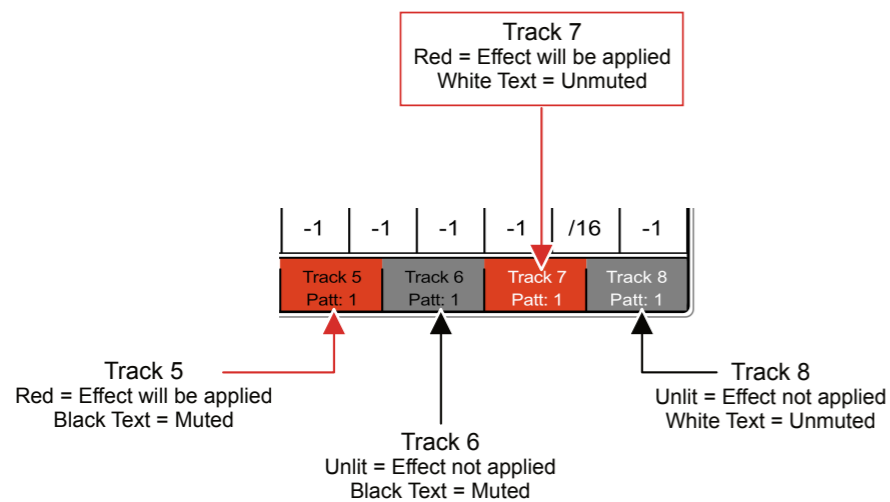

NOTES

NOTES

12.4 Perform Effect Values

Each of the configured effects has four slots which hold the value for the effect. These are triggered by the respective pad. The top row is reserved as a default 'off' and the other three values are set relative to the current effect parameter value. In addition a 'top row' of values are available to be controlled by MIDI CC inputs from external gear if desired.

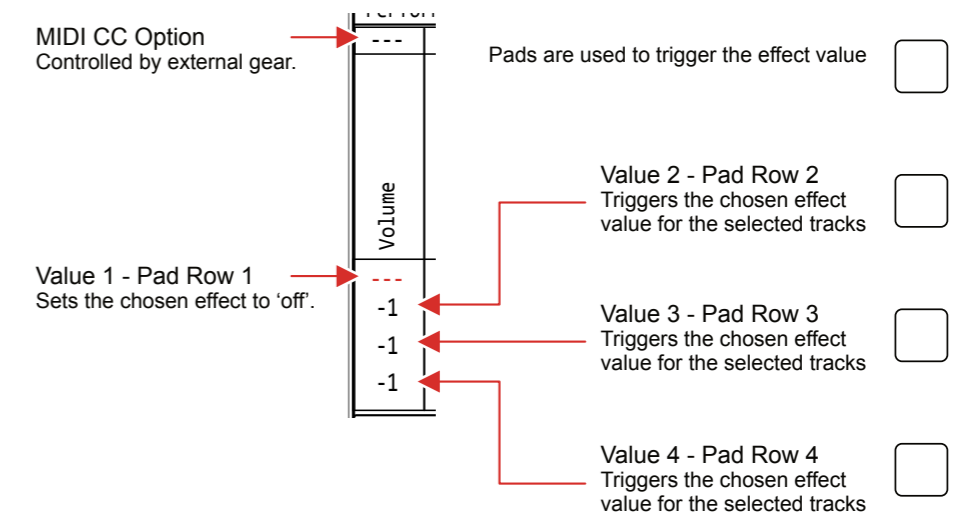

Value

Value is referenced as an offset applied to the current setting for the effect. The first row, value offset is off by default to allow a quick revert to the default state.

For example, with volume set at -10dB, the values are offset by each value, when triggered.

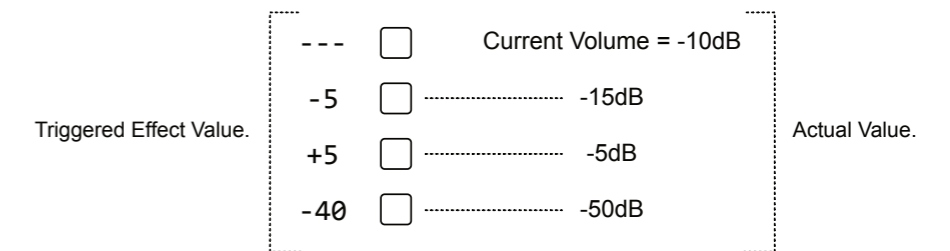

12.5 Configuring Effects

Effects can be setup in record mode with up to 12 effects being configured from a library of 21 performance effects. By default the performance preset is saved on a global basis, but can be changed to be saved 'per-project' in the 'Config' settings.

CREATING AN EFFECT TEMPLATE

1. Press [Perform] to select the Performance Mode page.
2. Press [Rec] to select record mode. Values and bounding box are red.
3. Navigate between effect slots, Press [Left] or [Right].
4. To cycle the effect for the selected slot, Press [Up] or [Down].
5. To swap effects, Hold [Shift] + [Right] or [Left]. This will swap the currently selected effect along with the values with the slot chosen. The pad value selections will remain with the original slot. This can also be used creatively.
6. Hold [PAD] + Turn (Jog) to change the value of the specific effect row. The selected Pad will be representative of the effect value. Pad row 2 is the 2nd row of effect values, Pad row 3, is 3rd row of effect parameters. Top row 1 is reserved to reset the value to the default.
7. Repeat steps 3 - 5 for other effect slots. 12 slots are available.
8. Press [Rec] to turn record mode off.

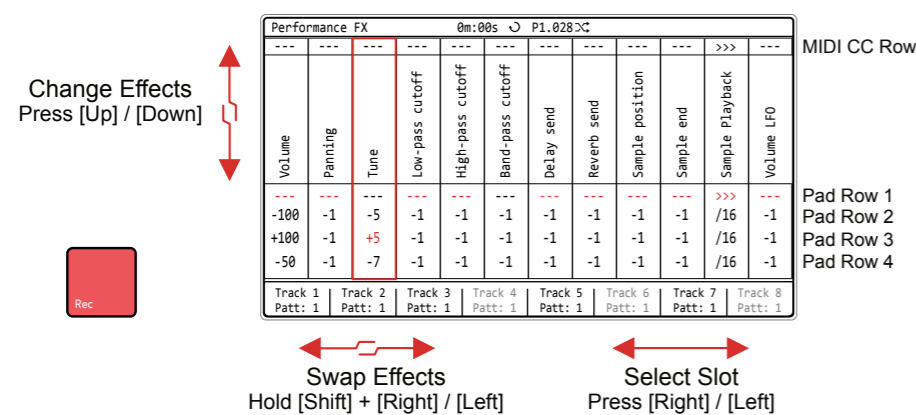

NOTES

NOTES

SETTING A TRACK PATTERN

1. Playback stopped.
2. Press [Perform] to select the Performance Mode page.
3. Hold [Track 1] to [Track 8] Screen button + Turn (Jog). This selects the pattern assigned to the chosen track. These can also be changed during playback as a real-time performance and remix technique.

CHANGING PERFORM TEMPLATE SAVE BEHAVIOUR

1. Press [Config] to open the project configuration menu.
2. Ensure the left window is highlighted red i.e. in focus. Navigate windows by pressing [Left] or [Right]. Menu windows will automatically be selected when pressing the relevant screen keys below the window to navigate [Up] or [Down].
3. Press [Up] [Down] or Turn (Jog) to highlight with the bounding box the 'Project Settings' option. Alternatively press the relevant screen keys below the left window to navigate [Up] or [Down].
4. Press [Up] [Down] or Turn (Jog) to highlight with the bounding box over the 'Performance preset' option in the central window. Alternatively press the relevant screen keys below the central window to navigate [Up] or [Down].
5. To change the selected parameter / setting, Press [Change]. The parameter pop-up window listing the available options will appear.
6. Turn (Jog) or Press [Up] / [Down] or [Up] / [Down] Screen buttons to highlight the desired option. The 'Global' setting will save the perform template for all projects while 'Per Project' will save on an individual project basis. Global is default.
7. Press [Apply] - 6th Screen button to confirm selection or [Cancel] - 3rd Screen button to exit without changing.

12.6 Perform Effects List

Tracker has 21 performance effects that can be selected and loaded into each of the 12 effect slots. The same effect can be applied to multiple slots. While these are called effects, they in fact control parameters that apply variations to the parameter values.

NOTES

Effect #	Name	Range / Comments
1	Volume	-100 to +100. Volume level adjustment
2	Panning	-100 to +100 Stereo Position
3	Tune	-48 to +48 Semitones. Also applies to MIDI.
4	Low-Pass Cutoff	-100 to +100. Filter frequency adjustment
5	High-Pass Cutoff	-100 to +100. Filter frequency adjustment
6	Band-Pass Cutoff	-100 to +100. Filter frequency adjustment
7	Reverb Send	-100 to +100. FX Send level
8	Delay Send	-100 to +100. FX Send level
9	Sample Position	-100 to +100. Audio sample start position
10	Sample End	-100 to +100. Audio sample end position
11	Sample Playback	<<< >>> Backward, Forward direction.
12	Volume LFO Speed	-28 to +28. LFO Speed
13	Panning LFO Speed	-28 to +28. LFO Speed
14	Finetune LFO Speed	-28 to +28. LFO Speed
15	Filter LFO Speed	-28 to +28. LFO Speed
16	Grain/WT LFO Speed	-28 to +28. LFO Speed
17	Step Repeater	Off, 16, 12, 8, 6, 4, 3, 2, 1, 1/2, 1/3, 1/4, 1/6, 1/8, 1/12, 1/16.
18	Pattern Play Mode	Fwd, Back, Rnd, C1-C20 Fixed or Predefined algorithm 'C' play modes
19	Pattern Length	1-128 Total length (all tracks - selected or not)
20	Bit Depth	-12 to +12 Bit depth adjustment
21	Overdrive	-100 to +100 Overdrive adjustment

NOTES

12.7 Remixing

Tracker can remix tracks on the fly. There are two techniques worth noting when applying track mixing. Firstly the 'Pattern Play Mode' effect has 20 algorithms C1-C20 that allow pattern mixing based on predefined shuffling of existing patterns. This is called 'Custom Play Mode'. Secondly tracks can manually be remixed live when playing a song. Both techniques operate in performance mode.

Custom Play Mode

■ USING A CUSTOM PATTERN PLAY EFFECT

1. Press [Perform] to select the Performance Mode page.
2. Press [Rec] to select record mode. Values and bounding box are red.
3. Navigate between effect slots, Press [Left] or [Right].
4. To load the effect for the selected slot, Press [Up] or [Down]. Select the 'Pattern Play Mode' effect.
5. Hold [PAD] + Turn (Jog) to change the value of the specific effect row. Fwd-Forward, Rev- Reverse and Rnd - Random options as well as 'C' options. Set the following example as a starting point. Any C1-C20 value can be selected:-
 - Pad row 2 is the 2nd row of effect values Set to C18.
 - Pad row 3, is 3rd row of effect parameters. Set to C19.
 - Pad row 4, is the 4th row of effect parameters. Set to C20.
6. It is possible to set up, other 'Pattern Play Mode' effects into other slots to cover more of the other C1-C17 custom presets.
7. Press [Rec] to turn record mode off.
8. Trigger the pads to activate the alternate mixes based on the predefined 'C' Setting triggered. Also it is possible to use slot 1 as a dynamic and temporary change by holding [PAD] Row 1 and Turning (Jog). This will clear when released.

Manual Play Mode

MANUALLY REMIXING PATTERNS ON THE FLY

1. Press [Perform] to select the Performance Mode page.
2. Ensure [Rec] mode is off.
3. Press [Shift] + [Play] to play the Song. The patterns can be remixed across tracks while a song is playing so ensure that multiple patterns are available in the song. The perform icon indicates remix is possible.
4. Remix track playback:-
 - Hold [Track x], Screen button + Press [Left] or [Right]. This will play the newly selected pattern when the current one completes. The pattern will flash red to show this is cued ready for the change.
 - Hold [Track x], Screen button + Press [Up] or [Down] or Turn (Jog). This will play the newly selected pattern immediately upon selection.
 - It is possible to hold one or more [Track x], Screen buttons at the same time to select patterns for multiple tracks simultaneously.
4. The patterns will play, led by the longest ones which loop play while shorter ones are cut.
5. Exit the performance mode. The changes made in performance mode are disabled upon exit.

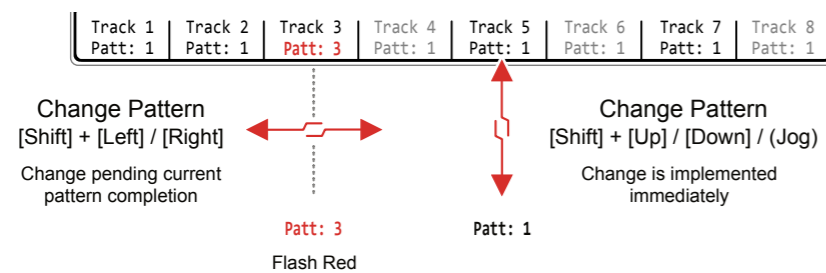

NOTES

NOTES

12.8 Controlling Performances with MIDI

An external MIDI controller can easily be assigned to control performance effects in perform mode. The MIDI Incoming CC's are predefined for the 12 effect slots and the 8 track selections. The top row of the performance effects are representative of the MIDI incoming values.

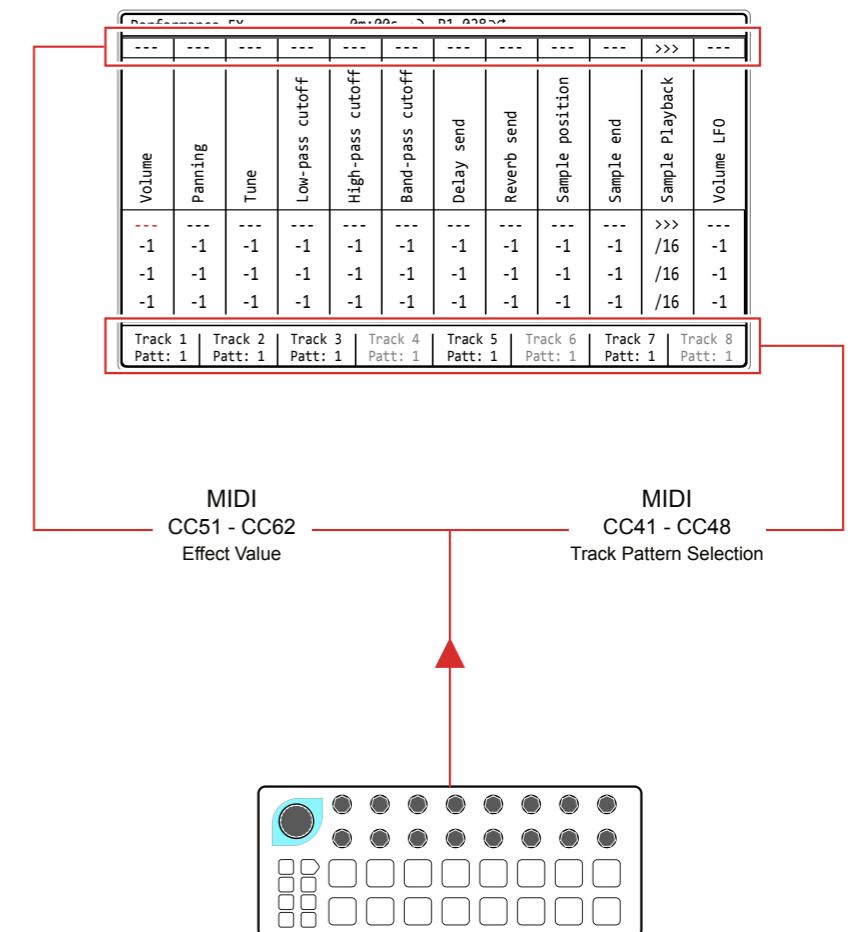

Example: Beatstep

Configured with rotaries to control the CC51-CC62 which sets the effect value. These can also have preset CC values triggered from the pads. The CC range on the controller is 0-127 which will be reflected across the range of the effect, which may be different. For example -100 to +100 Panning range will be controlled by a 0 to 127 CC Value.

Rotaries can also be set to select a track and a pattern using CC41-CC48. The value will represent the pattern which can also be assigned to a pad so that this triggers a specific pattern.

Ensure the MIDI settings for communication and the defined connection type are set correctly in the Config settings to ensure incoming MIDI control, clock, channel, transport etc are received correctly especially for the incoming CC data.

12.9 Advanced Pattern Playback

The simple option is to press [Play] to start and stop pattern playback. During playback a number of 'on-the-fly' pattern changes can be performed. This is more useful when improvising and performing.

PLAYING PATTERNS - REFRESHER

1. Press [Pattern] to select the Pattern page.
2. Press [Play] to play the current pattern.
3. Press [Play] to pause / stop a currently playing pattern.
4. Press [Song] + [Play] to play a song.
5. Hold [Song] to temporarily display the song page of press [Song] to switch to the song page from the pattern page.
6. Hold [Shift] + [Track x] Screen button to mute or unmute a track.

NOTES

NOTES

PLAYING PATTERNS - ADVANCED PLAYBACK

1. Press [Pattern] to select the Pattern page.
2. Press [Play] to play the current pattern.
3. Hold [*Pattern*], 1st Screen button to check available patterns, represented by lit pads.
4. To sequentially change the pattern on the fly:
 - Press [Pattern] + [Left] or [Right] buttons to select a new pattern. This will initiate a sequential pattern change which awaits the end of the current pattern before switching to the new pattern selection. Pattern text for the screen button flashes red when cued.
 - Press [*Pattern*], 1st Screen button + [Left] or [Right] buttons to select a new pattern. This will initiate a sequential pattern change which awaits the end of the current pattern before switching to the new pattern selection. Pattern text for the screen button flashes red when cued.
4. To immediately change the pattern on the fly:
 - Press [Pattern] + [Up] or [Down] buttons to select a new pattern. The (Jog) wheel can be used instead of the arrow keys. This will initiate a pattern change immediately.
 - Press [*Pattern*], 1st Screen button + [Up] or [Down] buttons to select a new pattern. The (Jog) wheel can be used instead of the arrow keys. This will initiate a pattern change immediately.
 - Press [*Pattern*], 1st Screen button + [PAD], for the new pattern. This will initiate a pattern change immediately.

13

System

While on face value this section may appear like the boring bit (I guess in many ways that could be true), but don't overlook the content. While things like firmware updates are considered rare or one off activities, there are also some elements that at least are useful to be aware of. There are some useful tips and advise that may help if you are in a sticky situation. Also there are some topics that might be useful around housekeeping and good disciplines in working with Tracker. But there are also some tips that may be helpful beyond the administrative duties. For example capturing screen images is an often overlooked feature and can be an aid to storing settings that you might want to refer to later or share with others. The visual style and fonts for the screen and pad brightness can be adjusted and options on how these can be changed based on personal taste are provided. Of course the general firmware update options

are also covered in this section, although it is recommended to always follow Polyend's guidelines and instructions with each firmware release as it is possible these may change per update. The current firmware version can be checked in the startup screen and in the firmware config page. Registration of the device is required to access downloadable content and firmware updates. Registration is performed at at [Polyend.com](https://polyend.com). This section not only covers system wide features but also is a catch all for topics not covered elsewhere.

13.1 Device Registration

In order for Polyend to provide device support and to give access to future firmware updates, your Tracker must be registered on the Polyend website.

REGISTRATION / SUPPORT CHECKLIST

- Create an account at [Polyend.com](https://polyend.com).
- Register your device, ie Tracker in the relevant account section.
- Access firmware downloads in your account.
- Licence information is available at polyend.com/licenses/

NOTES

13.2 Generic Firmware Update

Firmware updates may be provided by Polyend from time to time, to fix bugs or add new features. The process of updating can be performed in several ways. When performing updates it is strongly advised to follow the Polyend instructions supplied with each update. The instructions here are a generic guide.

FIRMWARE UPDATE

1. Download the latest firmware. Access firmware updates for your device from your registered account at Polyend.
2. Copy the downloaded .ptf firmware file into the /Firmware folder. This can be found in the root directory of the SD Card.
3. Insert the SD card into Tracker and power up
4. Press [Config] to open the configuration and settings menu.
5. Navigate to the 'Firmware' menu. In the central window, select the firmware option to install.
6. Press [Confirm], Screen button.
7. The firmware will install and the on screen prompts provided will guide. The install process is typically less than 1 minute.
8. Tracker should restart, but press On/Off if a manual start is required after 100% of the update is completed.

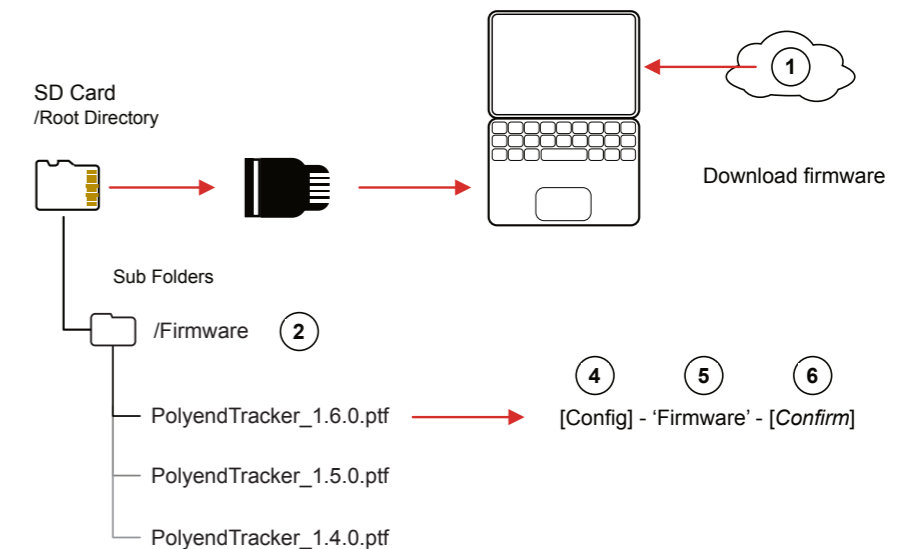

13.3 Emergency Firmware Update

Firmware updates are available from the polyend portal for your registered device. A reset button is provided, recessed behind the rear panel for emergency situations. A reset can be performed if there are issues with the update method or to clear Tracker issues but should not be used as a regular process for updates.

TRACKER & FIRMWARE RESET

1. Download the latest firmware. Access firmware updates for your device from your registered account at Polyend.
2. Copy the downloaded .ptf firmware file into the /Firmware folder. This can be found in the root directory of the SD Card. Also ensure any previous update files remain in the firmware folder.
3. Insert the SD card into Tracker.
4. Use a pin or thin object to press the internal reset button. This is located on the rear of the device behind the case next to the USB connection.
5. Tracker will reset and search the firmware folder on the SD Card. A random firmware will be selected and installed in order to recover Tracker to a working state. The install process is typically less than 1 minute.

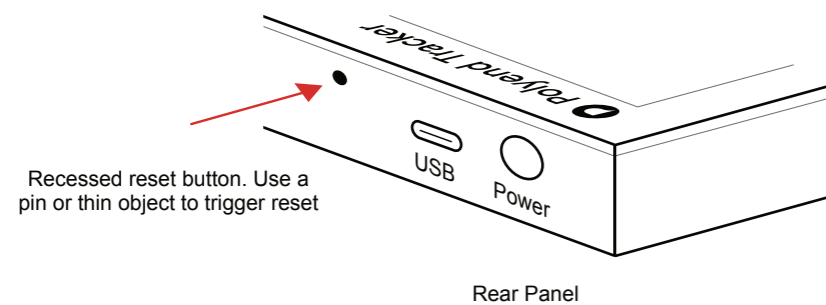

The reset option is useful if any lock ups or freezing occurs on Tracker. It is not necessary in these situations to download a new OS. It is advised to keep a series official, known good, firmware releases in the /firmware folder. For example 1.5.0, 1.6.0, 1.4.0. That way steps 4-5 can be performed in case of issues and a random update will be performed from a known state. A manual update in the 'config' menu to select the latest version can then follow.

NOTES

NOTES

13.4 Resetting the Configuration.

There may be occasions when the changes in configurations have caused problems and tracking back is not possible. An example may be that MIDI settings applied may need to be reset. The whole configuration settings can be reset to the defaults. This is performed in the config menu.

RESETTING CONFIG

1. Press [Config].
2. In the main menu list select the 'Firmware' option using the screen navigation buttons.
3. In the Firmware sub menu select 'Reset Config'.
4. Press [Apply], 6th Screen button and follow the prompts. Any previously changed settings will be restored back to default values.

13.5 User Interface Style.

The ability to change the display and pad style is available in the configuration setting. This may be useful when working in different environments and essentially is based on personal taste.

CHANGING USER INTERFACE STYLE

1. Press [Config].
2. Navigate using the screen buttons to the 'General' menu option.
3. In the central sub menu, four user interface elements exist:-
 - Display Brightness. Options are High (default), Medium and Low.
 - Display Theme. Options are Original (default) or Monochrome.
 - Display Font. Font for text. Options are original (default) or new.
 - Pads Brightness. Options are High (default), Medium and Low.
4. To change the setting highlight the desired sub menu option using the screen buttons or arrow keys.
5. Press [Change], 6th Screen button option. The available options as listed above are presented. Use the screen navigation or arrows to select the desired option.
6. Press [Apply], 6th Screen button option to confirm the selection.
7. The desired setting will be visible on the screen or pads.

NOTES

13.6 Screen Capturing

The ability to capture screen images from the currently displayed page is a built in feature of Tracker.

SCREEN GRAB OF CURRENT IMAGE

1. Select the page to capture.
2. Press [Shift] + On/Off Button. This is the power on button at the rear of the unit. This action is is not accompanied by any visual or audible acknowledgement of capture being completed.
3. The screen will be captured and saved onto the SD card as a .BMP image file in the snapshots folder.

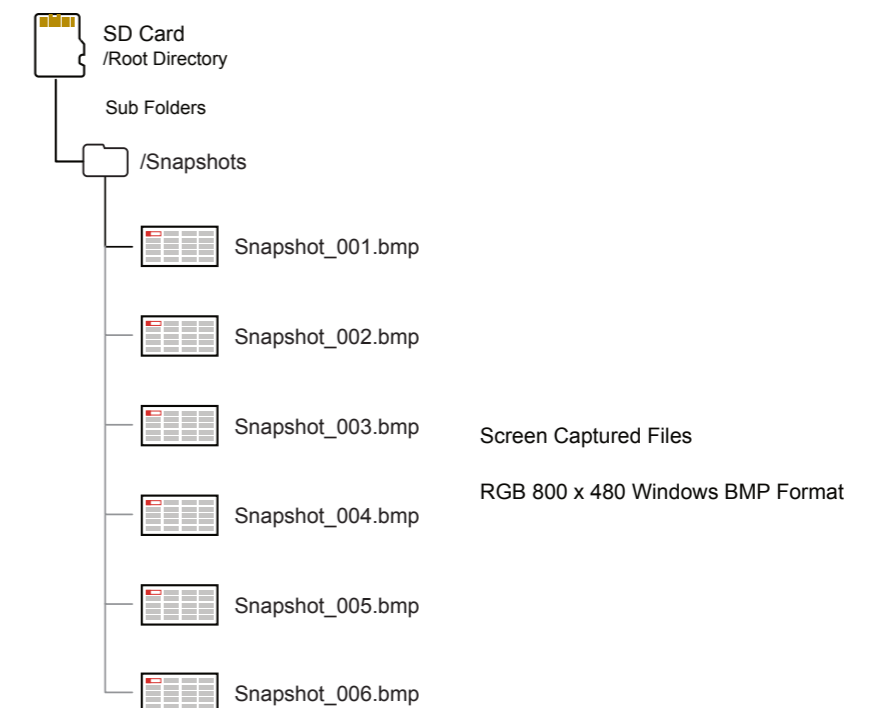

NOTES

13.7 Games

Tracker can run NES ROM games, and a collection are supplied readily available and stored in the SD Card games folder and accessed through the 'File' options. NES ROM files can be found online but there may be compatibility and performance issues with some. Some communities online have tested various games for using with Tracker. Load any other NES ROM files into the games folder on the SD to access.

ACCESSING THE GAMES

1. Press [File].
2. Press [Games], 8th Screen button. This will present the list of available games that are located in the SD Card /Games folder.
3. Scroll and navigate the list using the screen buttons, [Up] or [Down] buttons or Turn (Jog).
4. Press [Start], 7th Screen button to start the highlighted game.
5. Controls will vary depending on which game is playing. The typical key commands for control are:-
 - The [Up], [Down], [Right], Left] Arrow keys are used for navigation.
 - The [A] and [B], 1st and 2nd Screen buttons for control.
 - [Sel/Start], 8th Screen Button, Select/Start.
6. To exit a game, Press the rear On/Off Button.

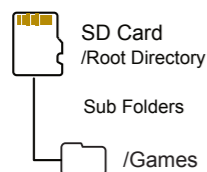

Additional, compatible .nes files can be downloaded from the web and when located in the /Games folder, will be accessible to Tracker.

Default Games List (.nes)

Alter_Ego
Chase
Lan
LawnMower
Utaco
ZoomingSecretary

NOTES

NOTES

13.8 SD Card Compatibility & Backing Up

It is always good practice to backup or even better have a spare SD Card loaded and ready for use with Tracker. The following information on SD compatibility is important:-

- A 16GB SD Micro SD Card is supplied with Tracker. Larger size SD cards can also be used. Supplied SD Card is: Sandisk Ultra, Micro SD, 16GB, HC1 A1.
- The format of the card must be FAT32 MBR (Master Boot Record). Other formats will not be recognised.
- Some folders and sub folders are created by Tracker based on the process carried out. Sample folders for example will be split when reaching 100 files.
- Tracker uses the SD card in real time and will not function without the SD card being installed. A 'bad' folder / file structure on the SD card may also cause Tracker problems.
- Some hidden folders exist for example the 'workspace' folder. It is good practice to create a duplicate copy of the SD card for backup purposes. Also if tracker does not boot up and crashes, restoring the full original folder / files structure or using the backup SD card is advised.
- Tracker is supplied with an SD Card USB reader for use with most Mac / PC's which helps transfer files.
- Polyend typically provide pre-release firmware as open beta. While this is great to get early insights into new features, by definition beta releases will have inherent problems. Only use beta versions to help test for bugs and features and do not use in a live gig or critical production environment.

Tip: SD cards can be notorious in there levels of performance with various gear. This is mainly due to the wide variety of speeds and specifications available. Gear producers do not and in fact cannot test every single SD specification or each of the manufacturers products. It is therefore recommended to stick as close as possible to the same SD Card type that the gear producer supplies with its gear. At least it is known that this SD card type will then have been tested thoroughly with the device itself by the device manufacturer as well as the user community.

NOTES

BACKING UP THE SD CARD FOLDERS & FILES

1. This is recommended as a first task when first operating Tracker to have the original structure saved. Also periodic backups is important to save the projects and files which will be created over time.
2. Use a compatible SD card reader or the supplied USB SD Adapter to connect the SD card to a PC or Mac.
3. Use the file manager (depends on the PC/Mac Operating System) to create a 'Tracker Backup' Folder in your documents folder and create a sub folder for each backup i.e. 'Original SD Aug21', 'Backup1 SD May22'. It is good practice to name backup folders by date.
4. Select all of the folders in the SD Card root directory and copy them to the PC/Mac clipboard.
5. Paste, the copied folders into the 'Tracker Backup' sub-folder for the specific backup.
6. Return the SD card to Tracker for normal operation.

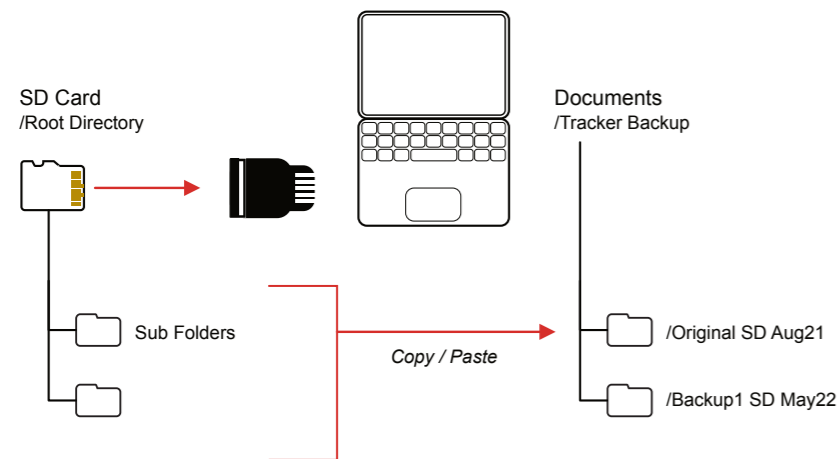

NOTES

13.9 Hexadecimal Option

The classic trackers typically used hexadecimal number format. This can be a little daunting if unfamiliar and especially in the more modern age and therefore decimal number is used as default. However, maybe for the more nostalgic users, numbering in hex mode is also an option.

CHANGING BETWEEN DECIMAL & HEXADECIMAL VIEW.

1. Press [Config] for the configuration settings.
2. Press [Up] or [Down], 1st & 2nd Screen buttons to navigate to the 'General' menu. The arrow keys and (Jog) also used in the left main menu list.
3. In the central window pane, Press [Up] or [Down], 4th & 5th Screen buttons to navigate to the 'Numbering mode' option. The arrow keys can be used to navigate in the central pane.
4. Press [Change], 6th Screen button. The options to change will appear.
5. Turn (Jog) or Press [Up] or [Down] to select between 'Decimal, Steps from 0' to use standard decimal numbers starting at step 0, 'Decimal, Steps from 1' where the decimal system is used and steps start at 1, and the 'Hexadecimal' option for a classic tracker view.
6. Press [Apply], 6th Screen button.

Hexadecimal to Decimal Converter

Hex	1	2	3	4	5	6	7	8	9	A	B	C	D	E	F
Dec	1	2	3	4	5	6	7	8	9	10	11	12	13	14	15

13.10 Official Specifications

NOTES

Audio Input:

- Unbalanced Mono, TS (Tip-Sleeve)
- Line Input:
 - Audio Input Impedance: 29 kOhm Impedance.
 - Input level: 8.2 dBu peak
 - Signal to Noise Ratio: 90 dB.
- Microphone Input:
 - Microphone Input Impedance: 2.9 kOhm Impedance
 - input level: 8.2 dBu peak.

Audio Output

- Line Output:
 - Output level 9 dBu peak (when 10k Ohm Load).
 - Signal to Noise Ratio: 97 dB.
- Headphone Output:
 - Output level: 17.6 dB (when 16k Ohm Load)
 - Signal to Noise Ratio: 98 dB.

NOTES

13.11 Supplied Accessories

Whats in the Box?

- Original USB A power adapter (with different standard plugs set). Branded USB-C cable (2 m).
- 1x Stereo 3.5 mm jack to 2x 6.3 mm jack adapter.
- 1x MIDI Type B, 3.5 mm jack to DIN adapter.
- 16GB Micro SD Card.
- Micro SD to USB-A dongle adapter.
- Warranty & Safety and Polyend Play Essential information brochures

14

Index

- 1-Shot Play Mode 114, 116, 118, 122, 130
- A**
- Adding Steps 62
 - ADSR 111
 - Amplifier 201
 - Antenna 183
 - Arm 86
 - Arpeggiator 148
 - Audio Editing 198
 - Audio Effects 199
- B**
- Backing Up 282
 - Backward Loop 116
 - Band Pass 164
 - Bass Boost 234
 - Bit Depth 168
 - Bitcrusher 202
 - Brightness 278
- C**
- Chance 146
 - Chords 90
 - Chorus 202
 - Compressor 203
 - Config 8, 36, 42
 - Copy 8, 54, 72
 - Crop 201
- D**
- Delay 166, 202, 228
 - Delete 33
 - Deleting Steps 63
 - Disarm 86
 - Display Theme 278
 - Duplicate Pattern 52
- E**
- Edit Steps 63
 - Effect 105, 226
 - Envelope 107, 111
 - EQ 235, 243
 - Equal Slicing 120
 - Equalizer 203–204, 235, 243
 - Euclidean Patterns 80–81
 - Expand Pattern 52
 - Export 192, 195
- F**
- Fade In 209
 - Fade Out 209
 - File 8
 - Fill 75–77, 80, 82, 85
 - Filter 159
 - Finetune 161
 - Firmware Update 275–276
 - Flanger 203
 - Font 278
 - Forward Loop 116
 - FX Descriptions 134
 - FX Types 96
 - FX1 Button 8
 - FX2 Button 8
- G**
- Games 281
 - Global Mixer 178
 - Granular 127
 - Grid Pads 8
- H**
- High Pass 165
- I**
- Import Instruments 41
 - Inserting Steps 63
 - Instrument Automation 107
 - Instrument Button 8
 - Instrument list 39
 - Instrument Parameter 8, 92, 100–102
 - Invert 55
- J**
- Jog Wheel 6, 8
- K**
- Keyboard 32
- L**
- LFO 107–108, 157–161
 - LFO Shape 108
 - LFO Speed 109
 - Limiter 203, 206, 232
 - Line Input 180
 - Live Recording 85, 87
 - Load 31
 - Loop 117
 - Low Pass 163
 - lower quality sample 41
- M**
- Manual Recording 69
 - Manual Slicing 120
 - Master 8, 176
 - Master Pages 176
 - Metronome 36, 58
 - Mic Input 182
 - Micro SD Card 7

- Micro-Tune 140
- MIDI 243
- MIDI CC In 252, 255, 257, 260
- MIDI CC Out 249
- MIDI Configuration 241
- MIDI Definitions 240
- MIDI Instruments 246, 249
- MIDI Messages 172
- MIDI synthesizer 254
- MIDI Velocity 248
- N
- None 136, 138
- Normalizer 201
- Note 88–89
- Note Button 8
- O
- Off 137, 139, 141
- Overdrive 162, 202
- P
- Page Map 26
- Panning 139, 141, 158
- Paste 8, 54, 72
- Pattern 48–50, 54, 56
- Pattern Length 51
- Pattern Number 51
- Pattern View 58, 60
- Perform Effect Values 263
- Perform Effects 266, 270
- Perform Mode 8
- Pingpong Loop 116
- Play 8
- Play Mode 113
- Playing Songs 220
- Polyphony 90
- Position 155, 160
- Power Off 9
- Power On 9
- Preview 69, 71
- Previewing Tracks 222
- Project 10, 29–30, 34, 36
- Project Management 31
- Q
- Quantize 86
- Quick Reference Commands 16–17
- QWERTY Keyboard 13, 25
- R
- Radio 183
- Random 150, 152
- REC 8
- Recording Audio 186
- Recording Mode 68
- Recording Options 86
- Render 90, 190–194
- Reset 276
- Reset Switch 7
- Reverb 167, 230
- Reverse 201
- Reverse Sample 154, 170
- Roll 147
- S
- Sample Editor 8, 198
- Sample Editor Effects 200
- Sample Formats 185
- Sample Loader 8
- Sample Playback 8, 113
- Sample Recorder 8
- Sampling 187
- Save 31–32
- Saving 31
- Screen Buttons 6, 8, 50
- Screen Capturing 280
- SD Card 282, 285
- Sharing Instruments 130
- Shift 8
- Shrink Pattern 53
- Slice 156
- Song Mode 8, 213
- Space 234
- Step FX Reference 135
- Step Jump 73–74
- Swing 143, 145, 147
- Synthesizer Mode 255
- T
- Tap tempo 34
- Tempo 34–35, 142, 144
- Timestretch beat 208
- Timestretch note 208
- Track Mixer 177
- Tracker Legacy Files 277, 279
- Tracks 12, 57, 61
- Transient Slicing 120
- Tune 169
- U
- USB Power 7
- User Interface Style 278

V

Volume 138, 153, 157

W

Wavetable 122, 130

Workflow 15

WT Smoother 125, 207

Copyright © 2022 by Polyend

All rights reserved. This book or any portion thereof may not be reproduced or used in any manner whatsoever without the express written permission of the publisher except for the use of brief quotations in a book review.

September 2023 - Tracker OS 1.7.0

Manual Produced in the United Kingdom

by

www.synthdawg.com

Synthdawg



 **Polyend**

